

CHAPTER 3

ELEMENTS OF DESIGN

3.0 INTRODUCTION

The design of highways and streets within particular functional classes is treated separately in later chapters. However, common to all classes of highways and streets are several principal elements of design, which include sight distance, superelevation, traveled way widening, grades, and horizontal and vertical alignments. These alignment elements are discussed in this chapter, and, as appropriate, in the later chapters pertaining to specific highway functional classes.

The alignment of a highway or street produces a great impact on the environment, community, and highway user. The alignment is comprised of a variety of elements joined together to create a facility that serves the traffic in a safe and efficient manner, consistent with the facility's intended function. Each alignment element should complement the others to produce a consistent, safe, efficient, and environmentally responsible design.

3.1 SIGHT DISTANCE

3.1.1 General Considerations

A critical element in assuring safe and efficient operation of a vehicle on a highway is the ability to see ahead. Sight distance is the distance along a roadway throughout which an object of specified height is continuously visible to the driver. This distance is dependent on the height of the driver's eye above the road surface; the specified object height above the road surface; and the height and lateral position of sight obstructions such as cut slopes, guardrail, and retaining walls within the driver's line of sight. Sight distance of sufficient length must be provided to allow drivers to avoid striking unexpected objects in the traveled way. Certain two-lane highways should also provide sufficient sight distance to allow drivers to occupy the opposing lane for passing without hazard.

Sight distance falls into three categories:

- Stopping (applicable on all highways)
- Passing (applicable only on two-lane highways)
- Decision (applicable at complex locations)

3.1.2 Stopping Sight Distance

Stopping sight distance is the sum of two distances:

- The distance a vehicle travels from the instant the driver sights an object necessitating a stop to the instant the brakes are applied (brake reaction distance), and
- The distance required to stop the vehicle from the instant brake application begins (braking distance).

Stopping sight distance is measured from the driver’s eyes, which are assumed to be 3.5 feet above the pavement, to an object 2 feet high on the road. Distances greater than the minimum stopping sight distance provide an additional measure of safety and should be considered where practical.

Stopping sight distances may be determined directly by calculating braking distance and brake reaction distance, and adding these values together, as described in the *PGDHS (1)*. Table 3-1 of this Guide shows sight distances for level roadways and roadways with grade for various design speeds. See also section 3.1.2.1 for adjustments for grades .

Design Speed (mph)	Stopping Sight Distance (Design Values)									Passing Sight Distance (2-Lane Road)	
	No grade adjustment	% Down Grade			% Up Grade			Crest	Sag	Crest Vertical Curve	
	Dist. (Ft)	3	6	9	3	6	9	K	K	Dist. (Ft)	K
15	80	80	82	85	75	74	73	3	10		
20	115	116	120	126	109	107	104	7	17	710	180
25	155	158	165	173	147	143	140	12	26	900	289
30	200	205	215	227	200	184	179	19	37	1090	424
35	250	257	271	287	237	229	222	29	49	1280	585
40	305	315	333	354	289	278	269	44	64	1470	772
45	360	378	400	427	344	331	320	61	79	1625	943
50	425	446	474	507	405	388	375	84	96	1835	1203
55	495	520	553	593	469	450	433	114	115	1985	1407
60	570	598	638	686	538	515	495	151	136	2135	1628
65	645	682	728	785	612	584	561	193	157	2285	1865
70	730	771	825	891	690	658	631	247	181	2480	2197
75	820	866	927	1003	772	736	704	312	206	2580	2377
80	910	965	1035	1121	859	817	782	384	231	2680	2565
AASHTO Exhibit (1)	(3-1)	(3-2)						(3-72)	(3-75)	(3-7) (3-73)	(3-73)

Table 3-1 Sight Distance

$$K = \frac{L}{A}$$

Where:

L = Length of curve, ft

A = Algebraic difference in intersecting grades, in percent

K value is a coefficient by which the algebraic difference in grade may be multiplied to determine the length in feet of the vertical curve that will provide minimum sight distance. Values of $K=167$ or greater should be checked for drainage.

3.1.2.1 Effect of Grade on Stopping Sight Distance

The safe stopping distances on upgrades are shorter; those on downgrades are longer. Design speed is used in calculating downgrade corrections; average running speed in calculating upgrade corrections. The different criteria for descending and ascending grades are based on the effect grades have on the speed of individual vehicles, particularly trucks; the effect these vehicles have on the overall speed of the traffic stream; and the premise that many drivers, particularly those in automobiles, do not compensate completely for the changes in speed caused by grades.

On nearly all roads and streets, the grade is traversed by traffic in both directions, but the sight distance at any point on the highway generally is different in each direction, particularly on straight roads in rolling terrain. As a general rule, the sight distance available on downgrades is larger than on upgrades, more or less automatically providing the necessary corrections for grade. Exceptions are one-way roads or streets, as on divided highways with independent design profiles for the two roadways, for which the separate grade corrections are in order and the refinement in design is in keeping with the overall standards used.

For those areas where there is a high volume of trucks, review “Variations for Trucks” in Chapter 3 of the *PGDHS* (1). See Table 3-1 for grade adjustments.

3.1.3 Decision Sight Distance

Exhibit 3-3 (1) provides values for appropriate decision sight distances at critical locations and for criteria in evaluating the suitability of the sight lengths at these locations.

Stopping sight distance may not be adequate when drivers are required to make complex or instantaneous decisions, when information is difficult to perceive, or when unexpected or unusual maneuvers are required. In these instances, stopping sight distances may not provide sufficient visibility distance for drivers to corroborate advance warnings and to perform the necessary maneuvers. Decision sight distance provides the greater length that drivers need.

Decision sight distance is the distance required for a driver to:

- Detect an unexpected or otherwise difficult to perceive information source or hazard in a roadway environment that may be visually cluttered.
- Recognize the hazard or its threat potential.
- Select an appropriate speed and path.
- Initiate and complete the required safety maneuver safely and efficiently.

Drivers need decision sight distances whenever there is a likelihood for error in either information reception, decision making, or control actions. The following are examples of critical locations where these kinds of errors are likely to occur and where it is desirable to provide decision sight distance:

- Interchange and intersection locations where unusual or unexpected maneuvers are required.
- Changes in cross section such as toll plazas and lane drops.
- Areas of concentrated demand where there is apt to be "visual noise" whenever sources of information compete, as those from roadway elements, traffic, traffic control devices, and advertising signs.

3.1.4 Sight Distance on Horizontal Curves

Sight distance on horizontal curves may be obtained with the aid of Figures 3-1 and 3-2 and Table 3-1 of this Guide and Exhibit 3-8 (1). For passenger vehicles, it is assumed that the driver's eyes are 3.5 feet above the center of the inside lane (inside with respect to the curve) and the object is 2 feet high. The line of sight is assumed to intercept the obstruction at the midpoint of the sight line and 2 feet above the center of the inside lane. The middle horizontal sightline offset (HSO) is obtained from Figure 3-1.

Horizontal sight distance may be measured with a straightedge, as indicated in Exhibit 3-8 (1).

As a matter of general case, consider the following:

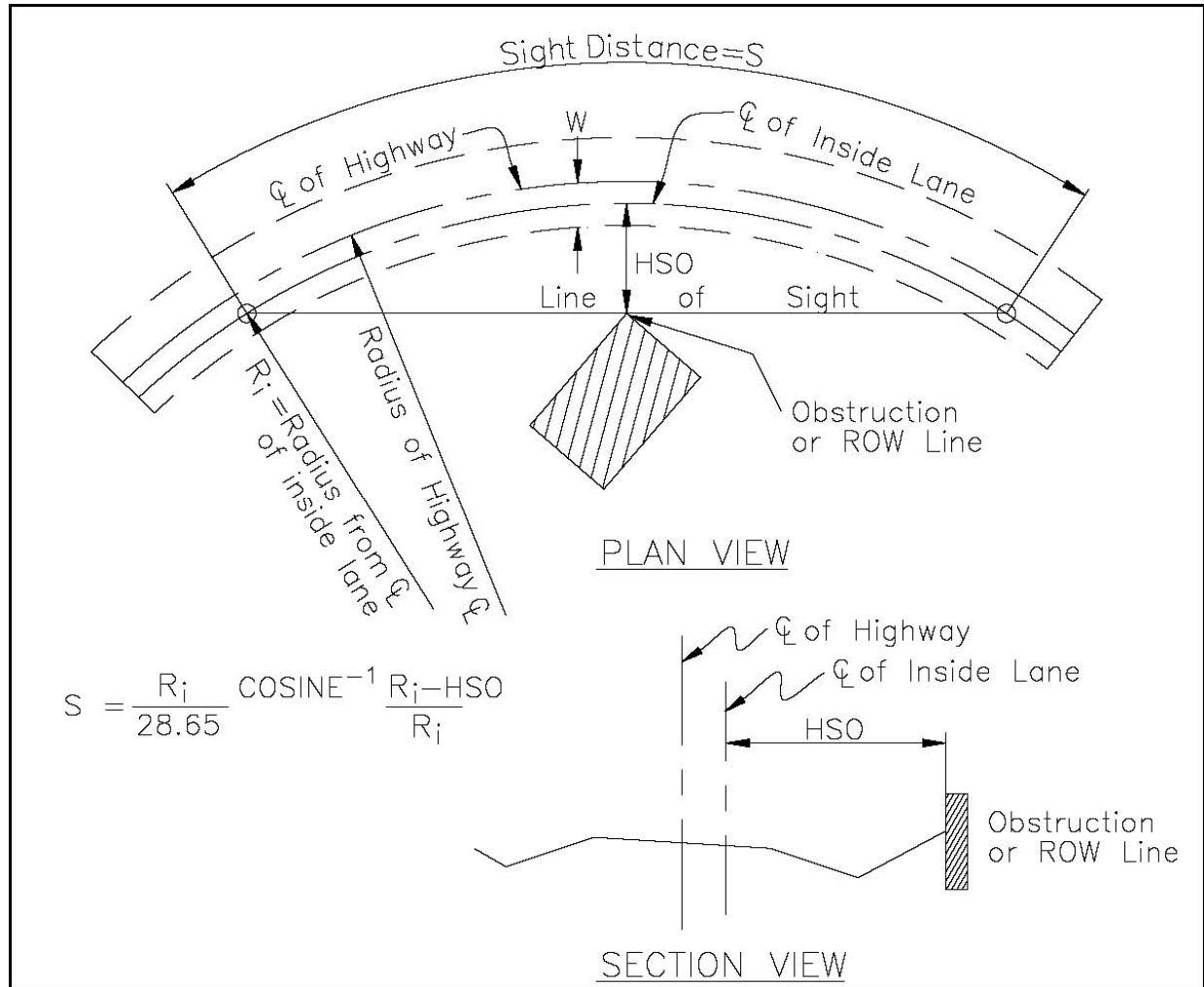

Figure 3-1 General Case – Stopping Sight Distance on Horizontal Curves

Where:

R_i = radius from centerline (C.L.) of inside lane (feet).

HSO = horizontal sightline offset (feet) (lateral distance from centerline of inside lane to ROW line or obstruction).

S = available stopping sight distance (feet)

To obtain Stopping Sight Distance, consider the following:

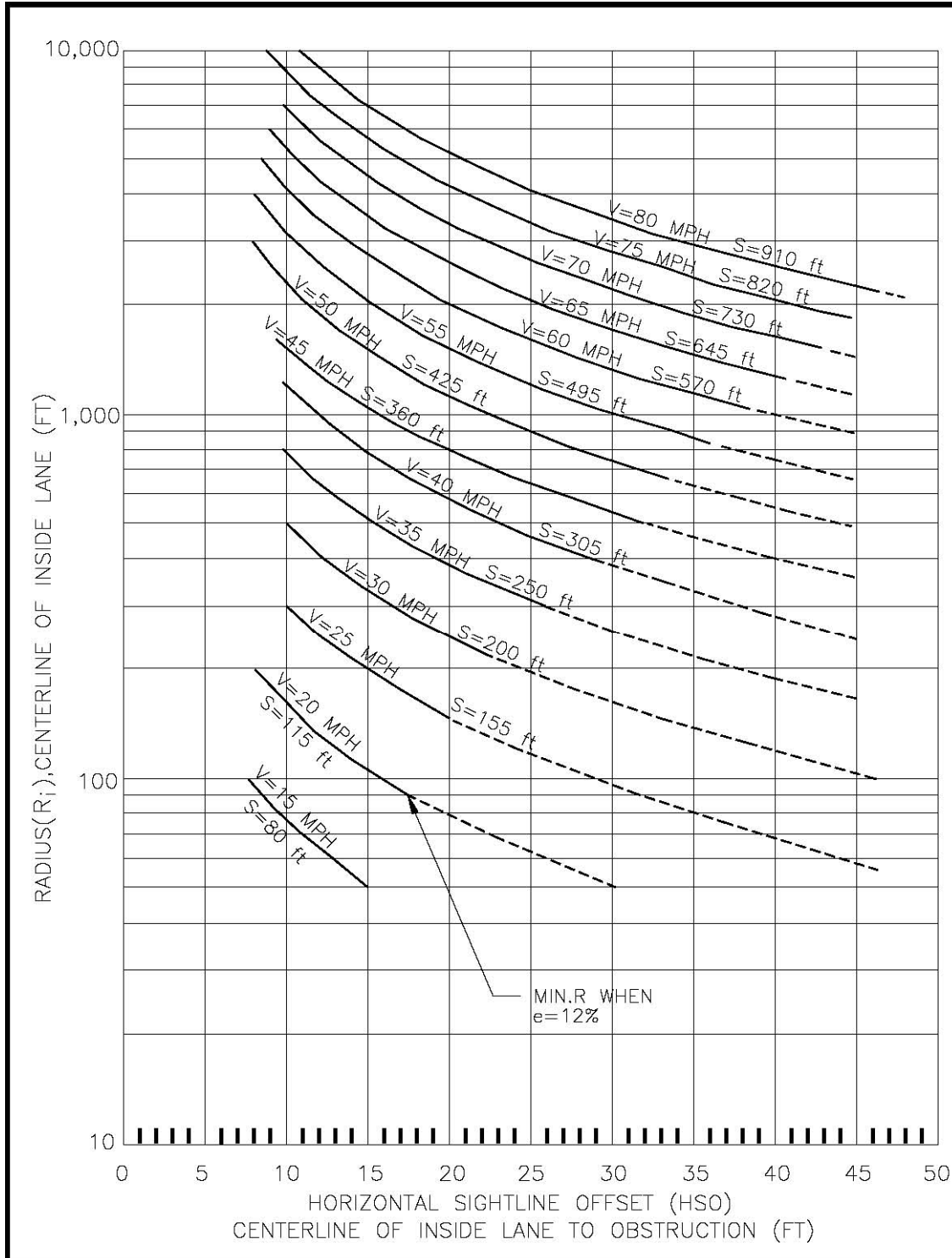

Figure 3-2 [Exhibit 3-53 (1)] Design Controls for Stopping Sight Distance on Horizontal Curves
 Note: this figure does not consider the effects of grade.

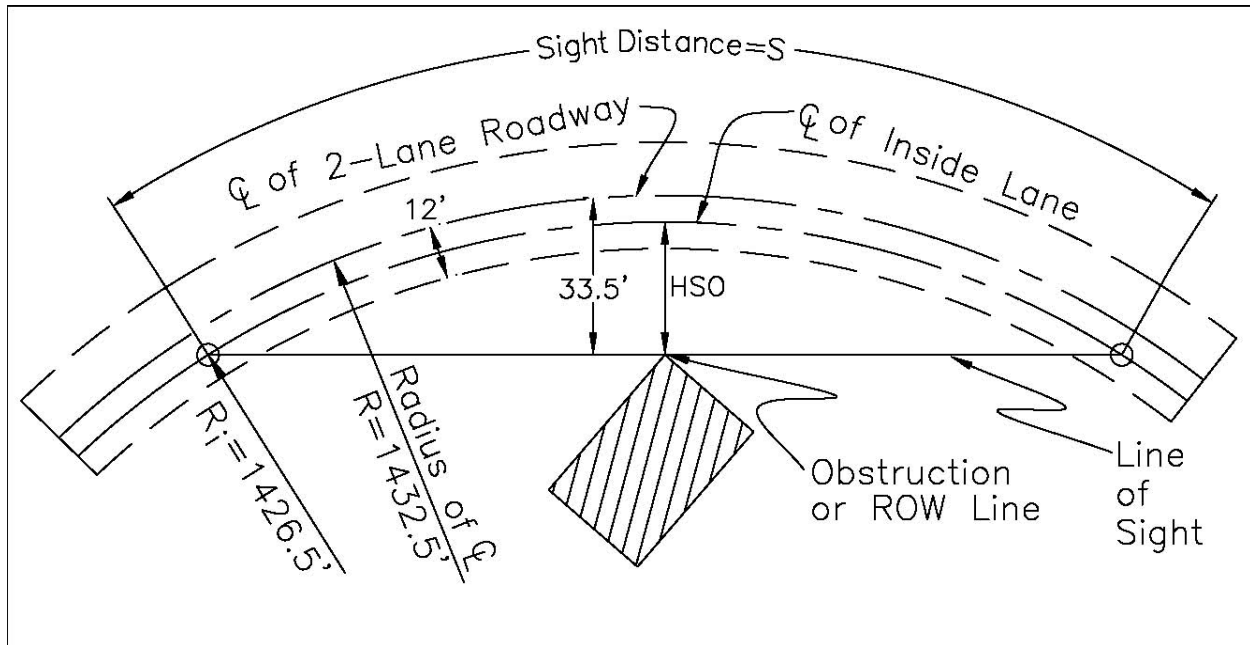

Figure 3-3 Example of Horizontal Stopping Sight Distance on a Two-Lane Roadway

$$R_i = 1432.5 - \frac{12}{2} = 1426.5 \text{ ft}$$

$$HSO = 33.5 - \frac{12}{2} = 27.5 \text{ ft}$$

$$\therefore S = \frac{1426.5}{28.65} \cos^{-1} \frac{1426.5 - 27.5}{1426.5} = 561 \text{ ft}$$

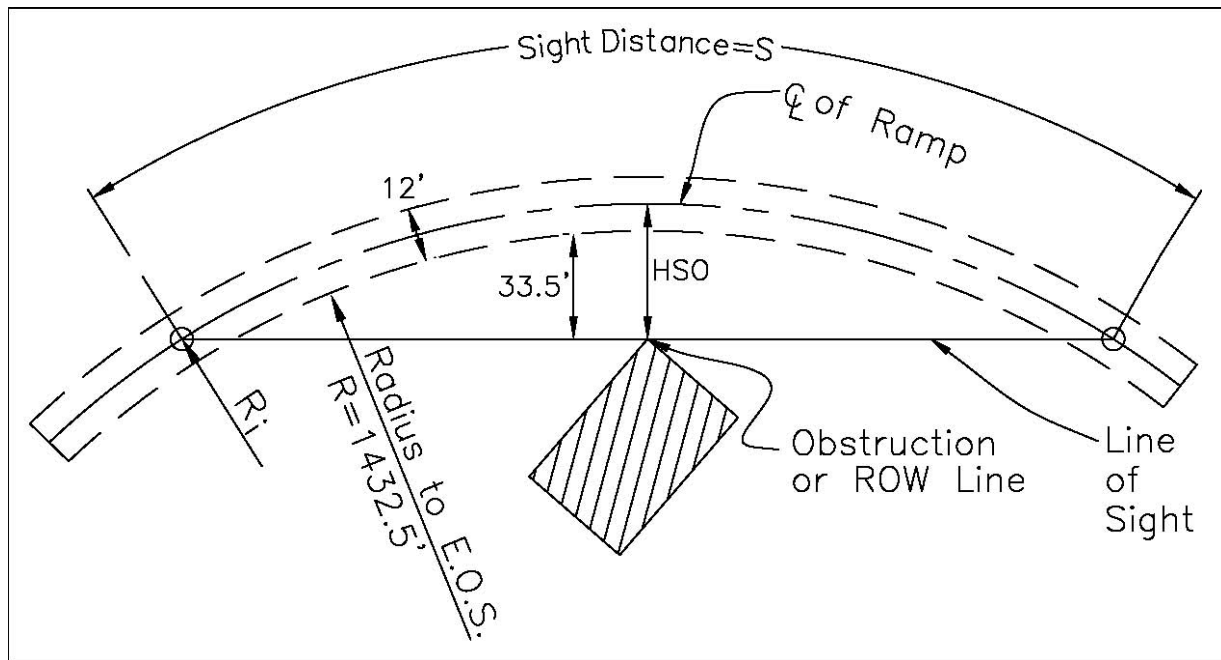

Figure 3-4 Example of Horizontal Stopping Sight Distance on a Ramp

$$R_i = 1432.5 + \frac{12}{2} = 1438.5 \text{ ft}$$

$$HSO = 33.5 + \frac{12}{2} = 39.5 \text{ ft}$$

$$\therefore S = \frac{1438.5}{28.65} \cos^{-1} \frac{1438.5 - 39.5}{1438.5} = 676 \text{ ft}$$

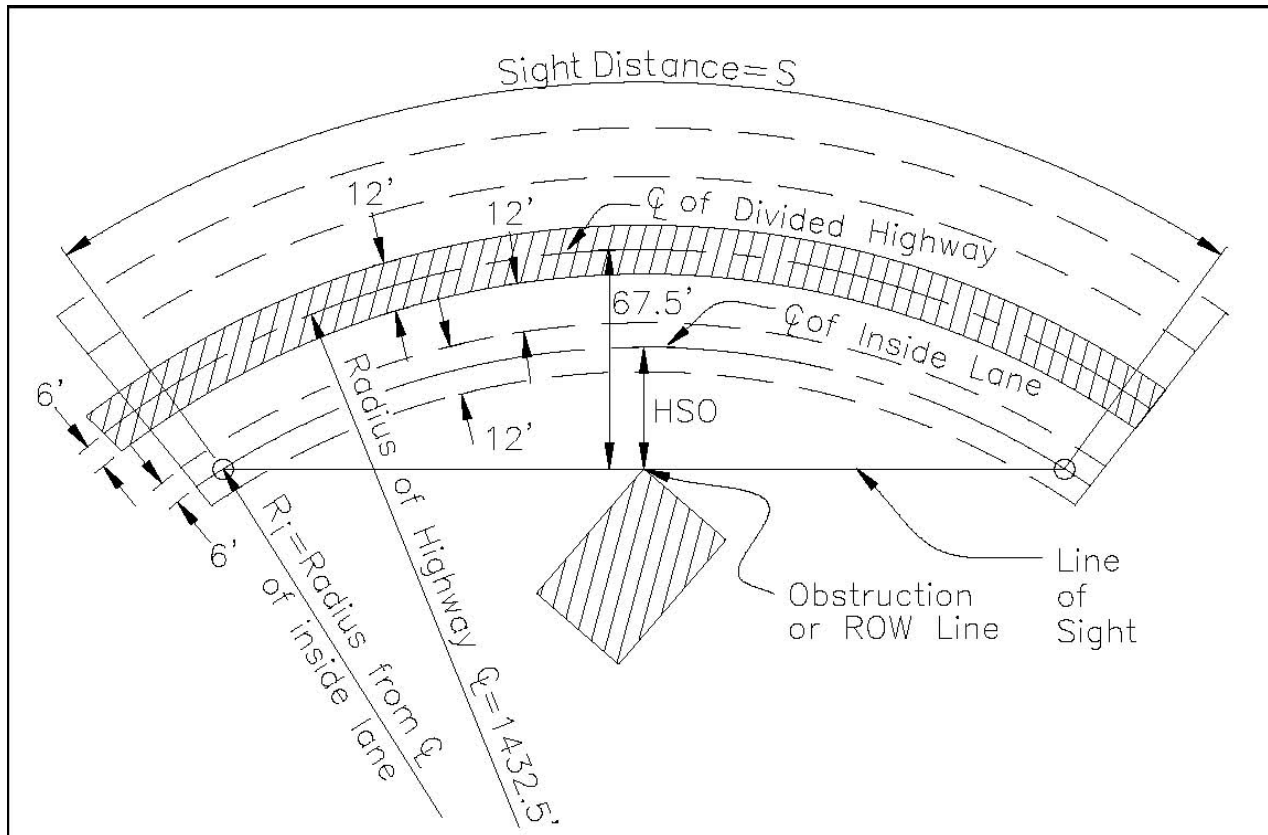

Figure 3-5 Example of Horizontal Stopping Sight Distance on Divided Highways

$$R_i = 1432.5 - \frac{12}{2} - 12 - \frac{12}{2} = 1408.5 \text{ ft}$$

$$HSD = 67.5 - \frac{12}{2} - 12 - \frac{12}{2} = 43.5 \text{ ft}$$

$$\therefore S = \frac{1408.5}{28.65} \cos^{-1} \frac{1408.5 - 43.5}{1408.5} = 702 \text{ ft}$$

Note: If a divided highway has median barrier, the horizontal stopping sight distance for the inside lane of the opposite direction should also be checked and shoulder widening considered. See Design Aid 100.

3.1.5 Sight Distance on Vertical Curves

3.1.5.1 Crest Vertical Curves

Stopping sight distance is measured when the height of eye and the height of object are 3.5 feet and 2 feet respectively.

When S is less than L,

$$S = \sqrt{\frac{2158L}{A}} \quad (i)$$

When S is greater than L,

$$S = \frac{L}{2} + \frac{1079}{A} \quad (ii)$$

L = length of vertical curve, in feet
 A = algebraic difference in grades, in percent
 S = Sight distance, in feet

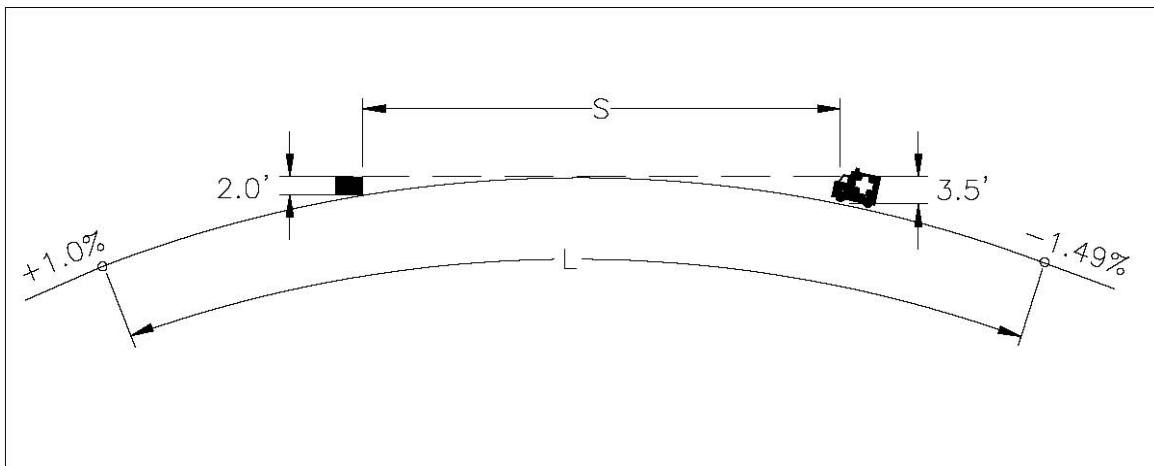

Figure 3-6 Example of Crest Vertical Curve

Given:

$L = 400$ feet, find S , K and design speed V .

$$A = 1.0 - (-1.49) = 2.49$$

Since it is unknown whether $S < L$ or $S > L$,

try (i):

$$S = \sqrt{\frac{2158L}{A}} = \sqrt{\frac{(2158)(400)}{2.49}}$$

$$S = 589 \text{ ft}$$

$$S(589) > L(400) \text{ No Good}$$

Try (ii):

$$S = \frac{L}{2} + \frac{1079}{A} = \frac{400}{2} + \frac{1079}{2.49}$$

$$S = 633 \text{ ft} > L(400) \text{ OK}$$

$$K = \frac{L}{A} = \frac{400}{2.49} = 160.6$$

From Table 3-1 for a $K(\text{CREST})$ value of 160.6, $V=60$ mph.

3.1.5.2 Sag Vertical Curves

Headlight sight distance is the basis for determining the length of sight distance. Prior to calculating the following formula, review Exhibit 3-74 (1) to ascertain if S is less than or greater than L .

When S is less than L ,

$$S = \frac{3.5L \pm \sqrt{12.25L^2 + 1600AL}}{2A} \quad (\text{iii})$$

When S is greater than L ,

$$S = \frac{AL + 400}{2A - 3.5} \quad (\text{iv})$$

Where:

L = length of sag vertical curve, in feet

S = light beam distance, in feet

A = algebraic difference in grades, in percent

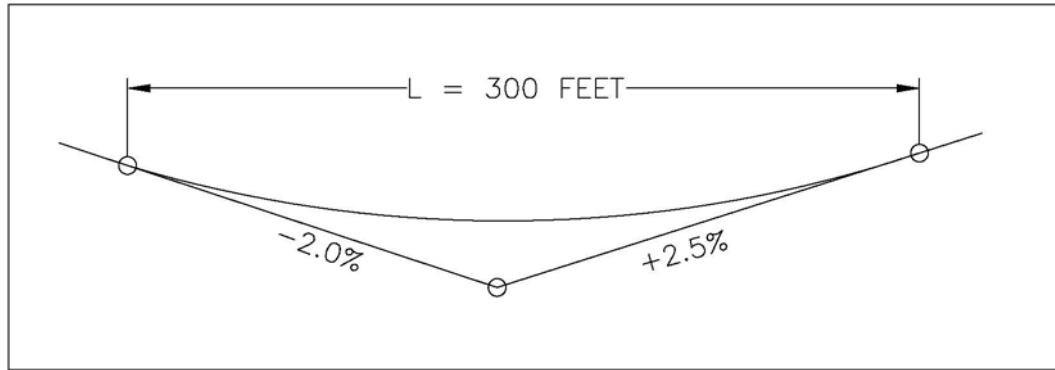

Figure 3-7 Example of Sag Vertical Curve

Given:

$L = 300$ feet, check if curve is adequate for a design speed of 40 mph, and find S .

$$A = 2.5 - (-2.0) = 4.5$$

$$K = \frac{L}{A} = \frac{300}{4.5} = 66.7$$

From "Sag K" column of Table 3-1, with $K(\text{Sag})$ value of 66.7, $V = 40.9$ mph.

\therefore Curve is adequate for a design speed of 40 mph.

Since it is unknown whether $S < L$ or $S > L$, try each equation or consult Exhibit 3-74(1).

try (iii):

$$S = \frac{3.5L \pm \sqrt{12.25L^2 + 1600AL}}{2A}$$

$$= \frac{(3.5)(300) \pm \sqrt{(12.25)(300)^2 + (1600)(4.5)(300)}}{(2)(4.5)}$$

=317, which is > 300 ... No good!

Try (iv):

$$S = \frac{AL + 400}{2A - 3.5} = \frac{(4.5)(300) + 400}{(2)(4.5) - 3.5} = 318 \text{ ft, which is } > 300 \text{ ...OK!}$$

3.1.6 Passing Sight Distance

Passing sight distance is the minimum sight distance required for the driver of one vehicle to pass another vehicle safely. Passing sight distance is considered only on two-lane roads. Passing sight distance is measured between an eye height of 3.5 feet and an object height of 3.5 feet.

Table 3-1 presents minimum passing sight distances for various design speeds.

Generally, it is impractical to design crest vertical curves to provide for passing sight distance because of the high cost where crest cuts are involved and the difficulty of fitting the required long vertical curves to the terrain, particularly for high speed roads.

Passing sight distance calculations are for design purposes only to assist in providing as many passing opportunities as possible. Actual passing and no-passing zone locations for striping need to be field measured and placed in accordance with the *Manual on Uniform Traffic Control Devices (MUTCD) (2)*.

3.1.6.1 Passing Sight Distance on Crest Vertical Curves

Design values of crest vertical curves for passing sight distance differ from those for stopping sight distance because of the different height criterion; i.e., 3.5 feet for the height of object for passing sight distance compared to 2 feet for stopping sight distance. The following formulas apply:

When S is less than L,

$$S = \sqrt{\frac{2800L}{A}}$$

When S is greater than L,

$$S = \frac{L}{2} + \frac{1400}{A}$$

For minimum passing sight distances, the required lengths of crest vertical curves are substantially longer than those for stopping sight distances, as evidenced by the values in Table 3-1. These lengths are significantly greater than the lengths necessary for stopping sight distances.

3.1.6.2 Passing and Stopping Sight Distances at Undercrossings

If economically feasible, passing sight distance should be maintained as the highway passes under a structure. On occasion, topographic conditions may result in a pronounced sag curve and the underside of the structure may limit the sight distance. Such conditions may best be checked graphically on the profile using the vertical clear dimension of the structure, the height of the eye for a truck driver as 8 feet and the height of object as 2 feet for the taillights of a vehicle. Minimum stopping sight distance must be maintained. See Exhibit 3-76 (1).

3.2 HORIZONTAL ALIGNMENT

3.2.1 General Controls

Horizontal alignment should provide for safe and continuous operation of vehicles at a uniform design speed for substantial lengths of highway.

The major considerations in horizontal alignment are:

- Topography
- Type of facility
- Design speed
- Profile grade
- Subsurface conditions
- Existing highway and cultural development
- Likely future developments
- Location of the highway terminals
- Right of way
- Safety
- Construction costs
- Environmental issues
- Geological features
- Drainage

All the above considerations should be balanced to produce an alignment that is appropriate for the location and functional classification of the highway. (Functional classification is explained in Chapter 1.)

To a large extent, topography controls both curve radius and design speed. In mountainous areas or areas subject to icing, consideration should be given to locating the road so that a southern exposure will be obtained wherever possible.

Geological features that may affect design, such as potential slide areas and subsurface water, should be investigated by the Materials and Geotechnical Branch.

Sight distance, compatible with the selected design speed, is required for proper design. Stopping sight distances are discussed in 3.1 Sight Distance.

Horizontal alignment must afford at least the minimum stopping sight distance for the design speed at all points on the highway, as given in Table 3-1.

Every effort should be made to exceed the minimum curve radii. Minimum curve radii should be used only when the cost of realizing a higher standard is not consistent with the benefits. The final considerations for the safety of any curve should be the combination of the factors of radius, sight distance, and superelevation (see section 3.2.3).

To avoid the appearance of inconsistent distribution, the horizontal alignment should be coordinated carefully with the profile design. General controls for this combination are discussed in section 3.4.

3.2.2 Types and Properties of Horizontal Alignments

3.2.2.1 Simple Curves

A simple curve is a circular arc joining two tangents.

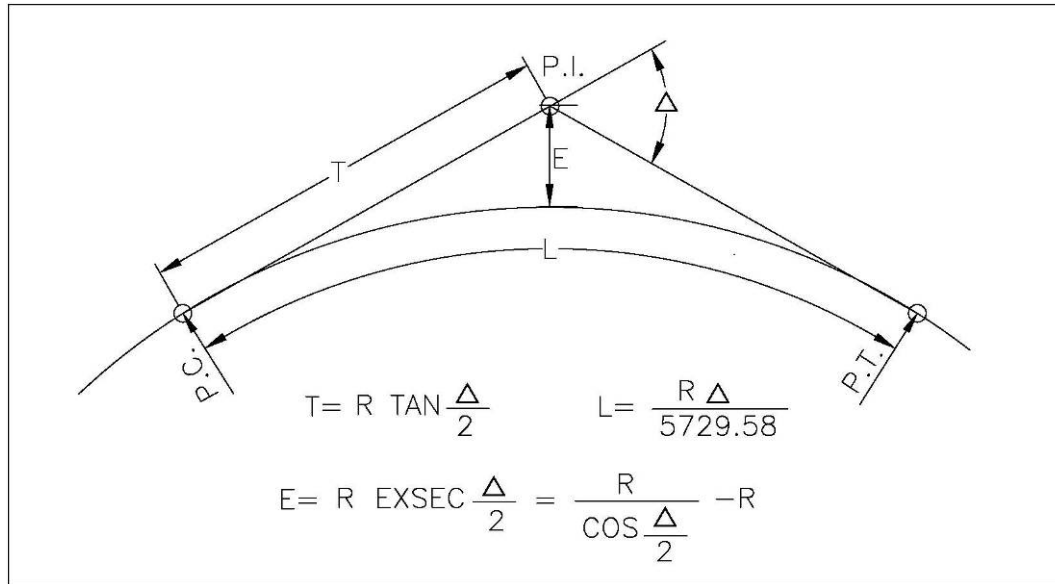

Figure 3-8 Simple Curve

Where:

R = radius of curve, ft

L = length of curve in stations

Δ = deflection angle between the tangents, decimal degrees

T = length of tangent, ft

E = external distance, ft

3.2.2.2 Spiral Curves

Spiral curves provide a gradual change in curvature from a straight to a circular path. Spiral transitions are not required but may be used on all roadways including ramps where recommended by the CDOT *Standard Plans - M & S Standards (3)* on superelevation, which also includes minimum transition lengths to be used with any given curvature and speed.

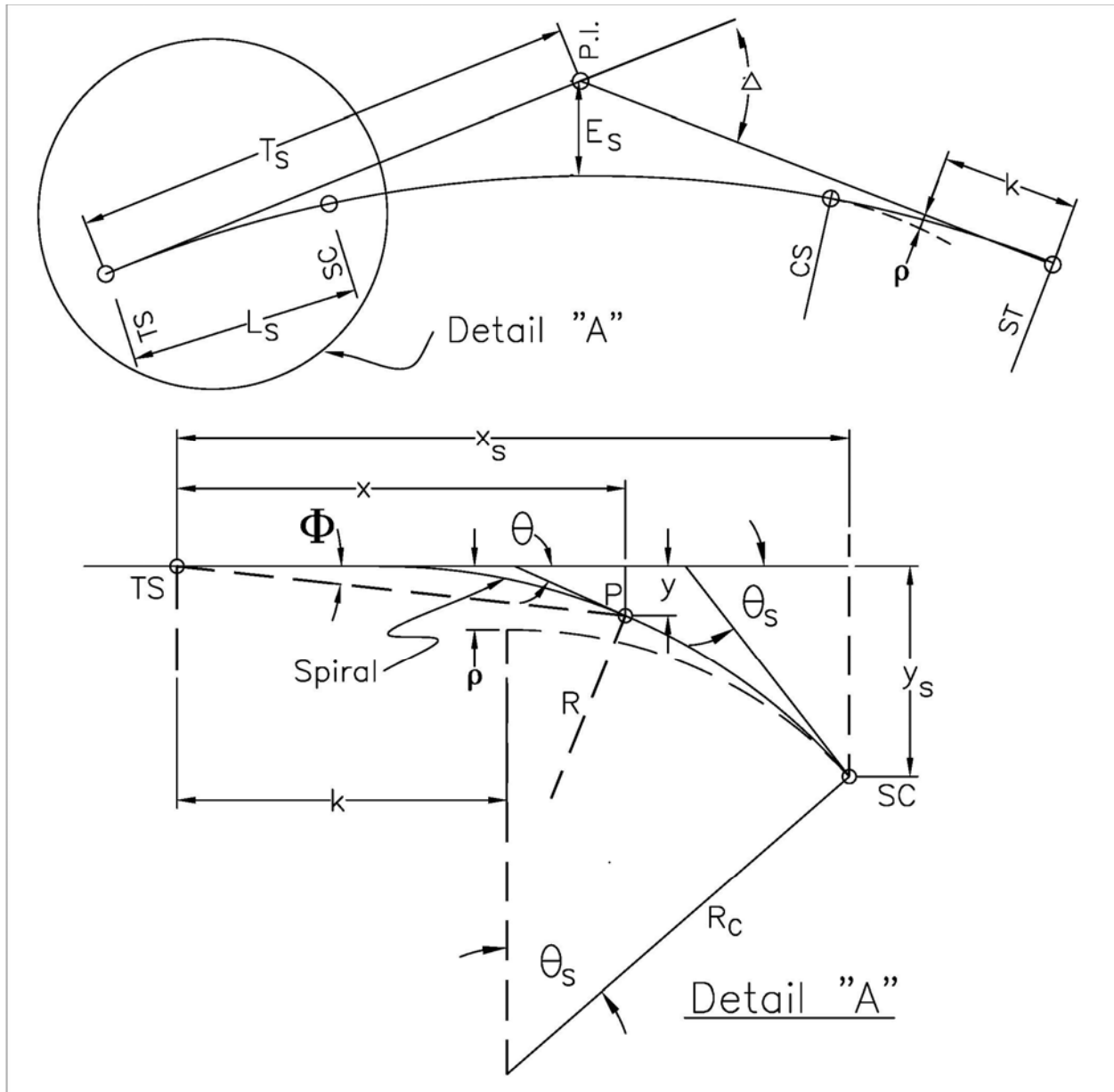

Figure 3-9 Spiral Curve

P is any point on the spiral curve.

Equations for the spiral curve are as follows:

$$T_s = (R_c + \rho) \text{TAN} \left(\frac{\Delta}{2} \right) + k$$

$$E_s = (R_c + \rho) \left(\frac{1}{\cos \frac{\Delta}{2}} - 1 \right) + \rho$$

$$= \frac{R_c + \rho}{\cos \frac{\Delta}{2}} - R_c$$

$$L_s = \frac{200 \theta_s}{D_c}$$

$$\theta = \left(\frac{L}{L_s} \right)^2 \theta_s$$

$$D = \left(\frac{L}{L_s} \right) D_c$$

$$y = \frac{ls}{100} (0.5818\theta_s - 0.1266 \times 10^{-4} \theta_s^3)$$

$$x = \frac{ls}{100} (100 - 0.3046 \times 10^{-2} \theta_s^2)$$

Where L is in feet and θ is measured in decimal degrees.

$$\rho = 0.001454\theta_s L_s$$

$$k = L_s (0.5 - 5.0770 \times 10^{-6} \theta_s^2)$$

where θ is measured in decimal degrees.

Where:

TS = point of change from tangent to spiral

SC = point of change from spiral to circle

CS = point of change from circle to spiral

ST = point of change from spiral to tangent

L = spiral arc from the TS to any point on spiral

L_s = total length of spiral from TS to SC

θ = central angle of spiral arc L

θ_s = central angle of spiral arc L_s , called "spiral angle"

Φ = spiral deflection angle at the TS from initial tangent to any point on spiral

D = degree of curve of the spiral at any point

R = radius

D_c = degree of curve of the shifted circle to which the spiral becomes tangent at the SC

R_c = radius of curve of the shifted circle to which the spiral becomes tangent at the SC

Δ = total central angle of the circular curve

Δ_c = central angle of circular arc of length L_c extending from SC to CS

y = tangent offset of any point on spiral with reference to TS and initial tangent

y_s = tangent offset at the SC

x = tangent offset of any point on spiral with reference to TS and initial tangent

x_s = tangent distance for the SC

ρ = offset from the initial tangent to the PC of the shifted circle

k = abscissa of the shifted PC referred to the TS

T_s = total tangent distance = distance from PI to TS, or from PI to ST

E_s = total external distance

For further information on spiral curves, see *Route Location and Design* by T .H. Hickerson (4).

3.2.2.3 Reverse Curves

Two consecutive circular curves constitute a reverse curve if they join at a point of tangency where their centers are on opposite sides of the common tangent. True reversing curves should be avoided, although they may at times be used in designing detours. In cases of reversing curves, a sufficient tangent should be maintained to avoid overlapping of the required superelevation runoff and tangent runout (see section 3.2.3).

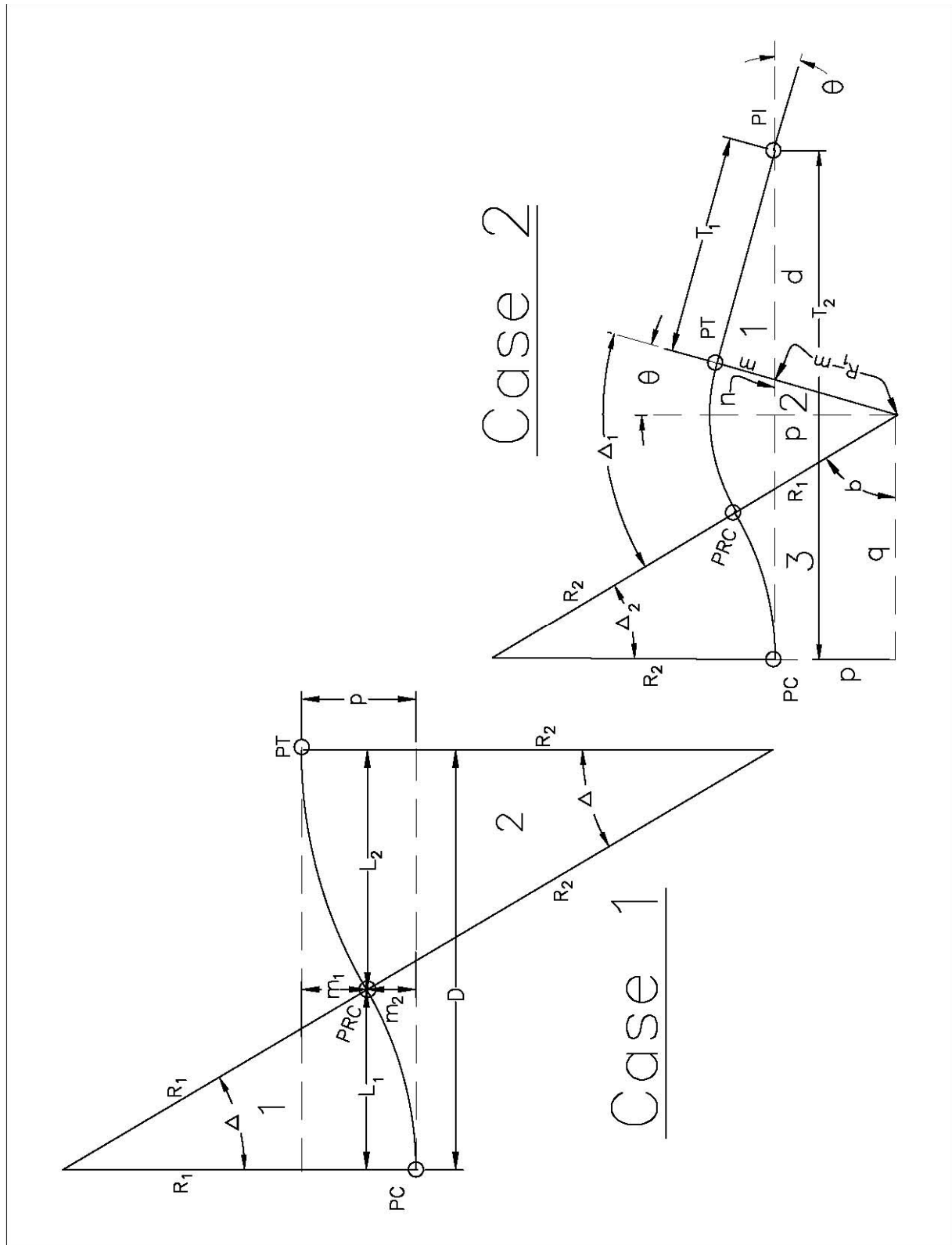

Figure 3-10 Reverse Curves

PRC = Point of Reversing Curvature.

In Case 1, the two parallel tangents are to be connected by a reversed curve (such as in a detour). R_1 , R_2 , and p are given.

From triangle 1,

$$\frac{L_1}{R_1} = \sin \Delta$$

$$L_1 = R_1 \sin \Delta$$

and

$$\frac{R_1 - m_2}{R_1} = \cos \Delta$$

$$m_2 = R_1(1 - \cos \Delta)$$

From triangle 2,

$$\frac{L_2}{R_2} = \sin \Delta$$

and

$$\frac{R_2 - m_1}{R_2} = \cos \Delta$$

$$m_1 = R_2(1 - \cos \Delta)$$

From which,

$$p = m_2 + m_1$$

$$p = R_1(1 - \cos \Delta) + R_2(1 - \cos \Delta)$$

$$p = (R_1 + R_2)(1 - \cos \Delta)$$

$$\frac{p}{R_1 + R_2} = 1 - \cos \Delta \quad (\text{i})$$

and

$$D = L_1 + L_2 \quad (\text{ii})$$

$$D = R_1 \sin \Delta + R_2 \sin \Delta$$

$$D = (R_1 + R_2) \sin \Delta \quad (\text{iii})$$

From equations (i) (ii) and (iii) and the ordinary functions of a simple curve, all ordinary cases of reversed curves between parallel tangents can be solved.

In Case 2, the two tangents, intersecting with the angle θ , are to be connected by the reversed curve in which T_1 , R_1 , and R_2 are known, and the tangent distance T_2 and the central angles of the two branches (Δ_1 & Δ_2) are required.

In triangle 1, the base T_1 and the angles are known, from which the sides d and m can be computed.

In triangle 2, the hypotenuse is $R_1 - m$, and the angles are known from which the base p and the altitude n are determined.

In triangle 3, the base is $R_2 + p$, and the hypotenuse is $R_1 + R_2$, from which the angles Δ_2 and b and the distance q can be found.

$$\text{Then } \Delta_1 = \theta + \Delta_2$$

$$\text{and } T_2 = d + n + q$$

3.2.2.4 Compound Curves

Two consecutive circular curves constitute a compound curve if they join at a point of tangency where both curves are on the same side of the common tangent.

A compound curve on open highways should be avoided, particularly where a simple curve can be obtained at small extra cost. Where topography makes their use necessary, the ratio of the flatter radius to the sharper radius should not exceed 1.5:1. For compound curves at intersections or on ramps, the ratio of the flatter radius to the sharper radius should not exceed 2:1. When this is not feasible, an intermediate simple curve or spiral should be used to provide the necessary transitions. Refer to the *PGDHS (1)*, Chapter 3 for more discussion on compound curves at intersections

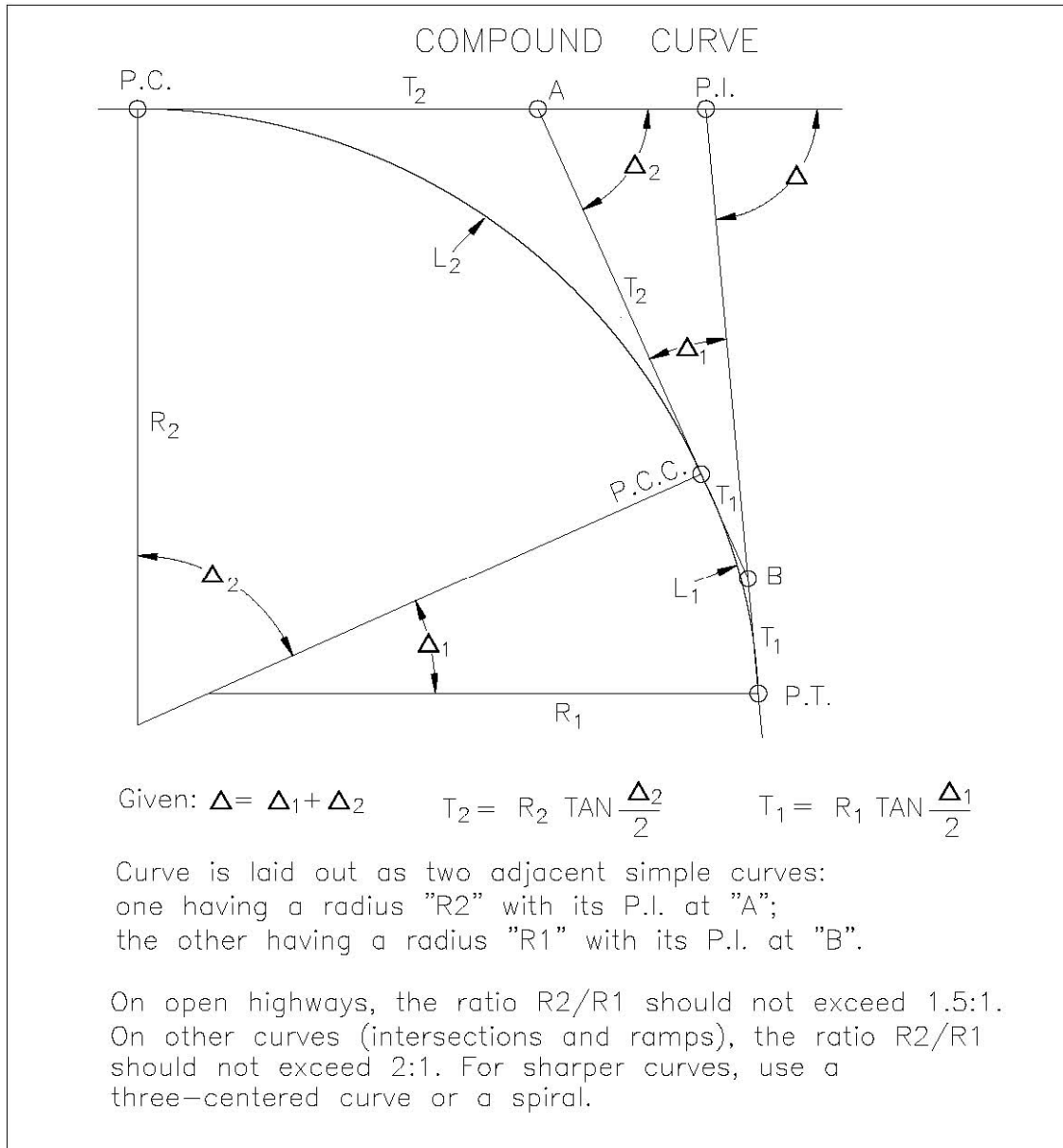

Figure 3-11 Compound Curve

3.2.2.5 Alignment on Bridges

Ending a curve on a bridge is undesirable and adds to the complication of design and construction. Likewise, curves beginning or ending near a bridge should be placed so that no part of the spiral or superelevation transitions extends onto the bridge. Compound curves on a bridge are equally undesirable. If curvature is unavoidable, every effort should be made to keep the bridge within the limits of the simple curve.

3.2.2.6 Curvature Zoning

In addition to the specific design elements for horizontal alignment discussed under previous headings, a number of general controls are recognized in practice. These controls are not subject to theoretical derivation, but they are important for efficient and smooth-flowing highways. Excessive curvature or poor combinations of curvature limit capacity, cause economic losses because of increased travel time and operating costs, and detract from a pleasing appearance. To avoid such poor design practices, the general controls that follow should be used where practical.

Consistent alignment should always be sought. Sharp curves should not be introduced at the ends of long tangents. Sudden changes from areas of flat curvature to areas of sharp curvature should be avoided. Where sharp curvature is introduced, it should be approached, where practical, by a series of successively sharper curves.

- **Broken-Back Curve**

A broken-back curve consists of two curves in the same direction joined by a short tangent (under 1,500 feet). Broken-back curves are undesirable. If used, a simple curve, a compound curve or spiral transitions should be used to provide some degree of continuous superelevation. Lengths need to be adequate to transition superelevation correctly.

The “broken-back” arrangement of curves should be avoided except where very unusual topographical or right of way conditions make other alternatives impractical.

- **Small Deflection Angles**

For small deflection angles, curves should be sufficiently long to avoid the appearance of a kink. Curves should be at least 500 feet long for a central angle of 5 degrees, and the minimum length should be increased 100 feet for each 1 degree decrease in the central angle. Horizontal curves should not be used when the central angle is 59 minutes or less.

- **Passing Tangents**

Passing tangents are used to provide passing opportunities on two-lane roads. One-half mile is considered an adequate length. Passing tangents should be provided as frequently as possible in keeping with the terrain.

An effort to introduce a passing tangent or to increase the length of a passing tangent is always worthy of reasonable expenditure. Nothing is gained if sweeping curves of large radii are used at the ends of a tangent if they reduce its length to less than that required for safe passing. It is better to use somewhat shorter radii and increase the intervening tangent to a more satisfactory length. At the other extreme, sharp curves at the ends of a passing tangent should be avoided as indicated above.

3.2.3 Superelevation

3.2.3.1 General

One of the most important factors to consider in highway safety is the centrifugal force generated when a vehicle traverses a curve. Centrifugal force increases as the velocity of the vehicle and/or the degree of curvature increases.

To overcome the effects of centrifugal force, curves must be superelevated. It is impossible to balance centrifugal force by superelevation alone, because for any given curve radius a certain superelevation rate is exactly correct for only one driving speed. At all other speeds there will be a side thrust either outward or inward, relative to the curve center, which must be offset by side friction. See the *PGDHS (1)* for further discussions on side friction.

See section 3.5 for superelevation of detours.

3.2.3.2 Standards for Superelevation

The CDOT *Standard Plans – M & S Standards (3)* on Superelevation give the required rate of superelevation for the various radius lengths at different design speeds for the maximum superelevation rate. See Standard Plans M-203-10, 11, 12, and 13. The values in the standard plans match those in Exhibits 3-25, 3-26, and 3-27 (1).

See section 3.5.6 for superelevation of detours.

A lower maximum rate of superelevation is generally used in urban areas than in rural areas.

The maximum superelevation rate may be less than shown on CDOT *Standard Plans – M & S Standards (3)* when the designer determines that the lower rate is required because of traffic congestion or extensive marginal development that acts to restrict top speeds.

For divided highways where median width is less than 60 feet, future inside widening of bridges or providing additional lanes requires the designer to properly plan the superelevation. Things to consider are:

- superelevation pivot point
- vertical clearance
- superelevation transitions

3.2.3.3 Superelevation Transition

Superelevation runoff is the term denoting the length of highway needed to accomplish the change in cross slope from a section with the adverse crown removed (one side superelevates at normal crown slope, the other side at zero slope) to the fully superelevated section, or vice versa. When a spiral is used, its length is used to accommodate the superelevation runoff.

Tangent runout is the term denoting the length of highway needed to accomplish the change in cross slope from a normal crown section to a section with the adverse crown removed (one side superelevates at normal crown slope, the other side at zero slope), or vice versa.

The length of the tangent runout is determined by the amount of adverse crown to be removed and the rate at which it is removed. This rate of removal should be the same as the rate used to effect the superelevation runoff.

The location, with respect to the curve, and the various lengths of the superelevation transitions are shown on the *CDOT Standard Plans - M & S Standards on Superelevation (3)*.

3.2.3.4 Design for All Rural Highways, Urban Freeways and High-Speed Urban Streets

On all rural highways, urban freeways, and urban streets where speed is relatively high and relatively uniform, horizontal curves are generally superelevated and successive curves are generally balanced to provide a smooth-riding transition from one curve to the next.

Exhibit 3-15 (1) gives minimum curve radius in feet for specific design speeds and the rates of superelevation. The table is based on design speed and superelevation alone and does not consider the sight distance factor.

3.2.3.5 Design for Low-Speed Urban Streets

Although superelevation is advantageous for traffic operations, various factors often combine to make its use impractical in many built-up areas. Such factors include wide pavement areas; need to meet the grade of adjacent property; surface drainage considerations; and frequency of cross streets, alleys and driveways. Therefore, horizontal curves on low-speed streets in urban areas are frequently designed without superelevation, counteracting the centrifugal force solely with side friction. On these curves, traffic entering a curve to the left has an adverse or negative superelevation due to the normal crown, but with flat curves and lower speeds the resultant friction required to counteract both the centrifugal force and the negative superelevation is small.

On successively sharper curves for the same design speed, the maximum degree of curvature or sharpest curve without superelevation is reached when the side friction factor developed to counteract centrifugal force and adverse crown reaches the maximum allowable value based on safety and comfort considerations. For travel on sharper curves, superelevation is needed.

The maximum superelevation rate of zero in Table 3-2 establishes the minimum radius for each speed below which superelevation is not provided on local streets in residential and commercial areas but should be considered in industrial areas or other streets where operating speeds will be higher. A maximum superelevation rate of 4 percent or 6 percent is commonly used. The maximum curvature for a given design speed is defined for low-speed urban streets when both the maximum superelevation rate and the maximum allowable side friction factors are utilized.

<i>e</i> (%)	R (feet) for Design Speed (mph)						
	15	20	25	30	35	40	45
-2.0	50	107	198	333	210	762	1039
-1.5	49	105	194	324	495	736	1000
0	47	99	181	300	454	667	900
1.5	45	94	170	279	419	610	818
2.0	44	92	167	273	408	593	794
2.2	44	91	165	270	404	586	785
2.4	44	91	164	268	400	580	776
2.6	43	90	163	265	396	573	767
2.8	43	89	161	263	393	567	758
3.0	43	89	160	261	389	561	750
3.2	43	88	159	259	385	556	742
3.4	42	88	158	256	382	550	734
3.6	42	87	157	254	378	544	726
3.8	42	87	155	252	375	539	718
4.0	42	86	154	250	371	533	711
4.2	41	85	153	248	368	528	703
4.4	41	85	152	246	365	523	696
4.6	41	84	151	244	361	518	689
4.8	41	84	150	242	358	513	682
5.0	41	83	149	240	355	508	675
5.2	40	83	148	238	352	503	668
5.4	40	82	147	236	349	498	662
5.6	40	82	146	234	346	494	655
5.8	40	81	145	233	343	489	649
6.0	39	81	144	231	340	485	643
Notes							
1. Computed using Superelevation Distribution Method 2.							
2. Superelevation may be optional on low-speed urban streets.							

Table 3-2 [Exhibit 3-16(1)] Minimum Radii and Superelevation for Low-Speed Urban Streets)

3.2.4 Widths for Turning Roadways at Intersections

See section 9.5.1.

3.2.5 Traveled Way Widening on Horizontal Curves

Curve widening is used primarily on pavements of substandard width or curvature. On open highway curves, the pavement should be widened as shown in Exhibit 3-47 (1), which is based on a WB-50 design vehicle. See Exhibit 3-48 (1) for curve-widening information for other design vehicles.

Widening is costly and little is actually gained from a small amount of widening. A widening of less than 2 feet may be disregarded.

3.2.5.1 Attainment of Widening on Curves

Widening should be attained gradually on the approaches to the curves, as shown in Figure 3-12 and Figure 3-13, to ensure a reasonably smooth alignment of the edge of the pavement and to fit the paths of vehicles entering or leaving the curves.

Widen (W) on the inside edge of the pavement and extend the transition over the same transition length (L) as the superelevation runoff.

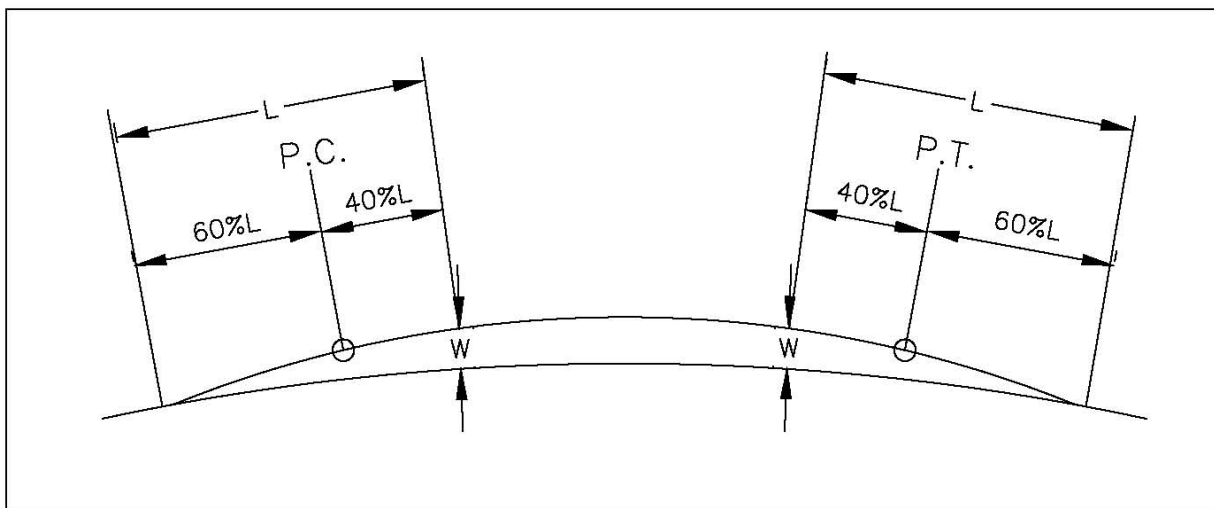

Figure 3-12 Widening on a Simple Curve

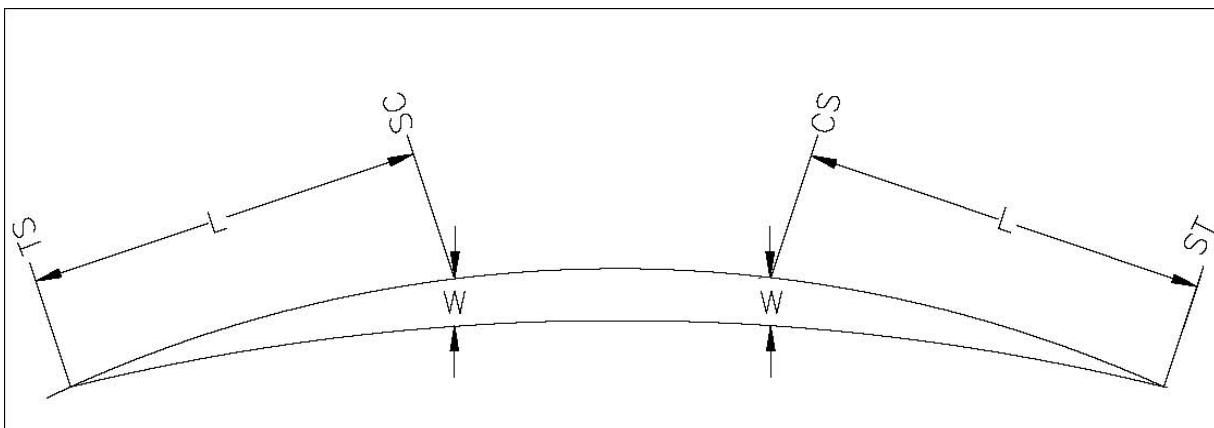

Figure 3-13 Widening on a Spiral Curve

From Section 6C.08 of the *MUTCD* (2).

$$\text{For } V \leq 40 \text{ mph} \quad L \geq \frac{WV^2}{60}$$

$$\text{For } V > 40 \text{ mph} \quad L \geq WV$$

Example:

Given:

pavement = 22 feet
 degree of curve = 9°
 radius = 636.62 feet
 icing conditions frequently exist, crowned highway

When $V = 30$ mph

From Exhibit 3-47(1), Widening (W) = approximately 3.5 feet
 From CDOT *Standard Plans -M & S Standards*, Superelevation
 Crowned Highways, $L = 100$ ft

$$\text{Since } V \leq 40, \frac{WV^2}{60} = \frac{3.5(30)^2}{60} = 52.5 \text{ ft}$$

$$\text{and } L > \frac{WV^2}{60} \text{ OK}$$

When $V = 50$ mph and curve radius = 760 feet with other parameters same as above,

From Exhibit 3-47(1), Widening (W) = approximately 4.3 ft
 From CDOT *Standard Plans -M & S Standards*, Superelevation
 Crowned Highways, $L = 240$ ft

$$\text{Since } V > 40 \text{ mph, } WV = 4.3(50) = 215 \text{ ft}$$

and $L > WV$...OK

3.2.6 Pavement Transitions

3.2.6.1 General

A pavement transition is the area of variable pavement width encountered when changing from one roadway width, or section, to another.

3.2.6.2 Two Lanes to Multilane Divided

This type of transition should be made only where sight distance is not restricted such as on a tangent section or on a flat curve. On a tangent section, the transition may be accomplished on either one or both lanes. A maximum of 1 degree reversing curves and a minimum total transition length of 1,000 feet should be used. This minimum length shall also apply where the transition is accomplished on a curve.

Design standards of the two lanes should be consistent with those of the multilane facility.

3.2.6.3 Other Transitions

Other, more simplified, transitions occur at speed-change lanes (see Chapter 9), truck climbing lanes (see section 3.3.5), and widening for curves (see section 3.2.5.1). All transitions shall be consistent with the design speed for the facility.

3.3 VERTICAL ALIGNMENT

3.3.1 General Controls

The grade line is a reference line by which the elevation of the pavement and other features of the highway are established. It is controlled mainly by topography and structure clearances, but the factors of horizontal alignment, safety, sight distance, design speed, construction costs, and the performance of heavy vehicles on a grade also must be considered.

In flat terrain, the elevation of the grade line is often controlled by drainage considerations.

In rolling terrain, an undulating grade line is often desirable, both from a standpoint of construction and maintenance economy. However, undulating grade lines involving substantial lengths of momentum grades should be appraised for their effect upon traffic operations since they may result in undesirably high downgrade truck speeds.

In mountainous terrain, the grade line is usually closely dependent upon physical controls, although adverse grades should be avoided. On divided highways, independent profiles with grade differential should be considered. Broken-back grade lines should always be avoided.

On long grades, it is preferable to flatten the grades near the top of the ascent particularly on low design speed highways.

In all cases, the consideration of adequate sight distance requirements and other safety factors should take precedence over construction and maintenance costs.

3.3.2 Position With Respect to Cross Section

The grade line should generally coincide with the axis of rotation for superelevation.

- On undivided highways, the grade line should coincide with the highway centerline.
- On ramps and interstate-to-interstate connections, the grade line is generally positioned at the left edge of the traveled way. Either edge of traveled way or centerline may be used on multilane facilities.

- On divided highways, the grade line should be positioned at the centerline of the median for paved medians 60 feet wide or less.

In selecting where the grade line is in relation to the axis of rotation for superelevation, the designer should consider the following:

- Future widening.
- Mountainous terrain.
- Right of way constraints.
- Topographic features.
- Earthwork.
- Matching existing typical sections (as-constructed plans).

Table 3-3 shows clearances to structures and obstructions for the various functional classifications.

	HIGHWAY UNDERPASSES		RAILWAY UNDERPASSES ***		OVERHEAD WIRES	
	HORIZONTAL	VERTICAL*	HORIZONTAL	VERTICAL* ‡	HORIZONTAL ^Δ	VERTICAL*
Local Rural Roads	E	14.5 feet	F	G	A	H
Local Urban Streets**					B	
Rural Collectors					C	
Urban Collectors**		16.5 feet #			D	
Rural Arterials						
Urban Arterials**						
Freeways						

A 10 feet from edge of traveled way.

B Use **A** when practical, but in any event, provide a minimum of 2 feet from curb face or from shoulder edge. See *AASHTO Standard Specifications for Structural Supports for Highway Signs, Luminaires, and Traffic Signals (5)*.

C ≤ 40mph use **A**
 ≥ 45 mph use **D**

D Use a clear zone according to the *AASHTO Roadside Design Guide (6)* or provide guard rail.

E Carry full approach roadway section through structure; minimum clearance from edge of through traffic lanes to walls, piers, or toes of slopes shall correspond to **D**, but, desirably, should not be less than 30 feet, unless guard rail is used. For tunnels and depressed roadways see the *AASHTO Standard Specifications for Highway Bridges (7)*.

F See *CDOT Bridge Design Manual (8)*, subsection 2.4.

G 23.5 feet (measured from top of rail to bottom of highway structure). For electrification, see *CDOT Bridge Design Manual (8)*, subsection 2.4.

H Communication lines and power lines of:
 0 to 22,000 volts 20.5 feet.
 22,000 to 50,000 volts 21.5 feet.

For voltages > 50,000, increase clearance 0.5 inch for each 1,000 volts over 50,000.

*All vertical clearances shown make allowance for future overlays or additional ballast on railroad. Vertical clearance applies to the full pavement width, including provisions for future widening.

**For low-speed urban conditions (≤ 40 mph) see Chapter 13.

***All railway clearances are subject to the individual railroad approval.

#May be reduced to 14.5 feet in Special Cases [See the *PGDHS (1)*].

‡Vertical clearance to sign trusses and pedestrian overpasses shall be 17.5 feet.

ΔHorizontal clearance is distance to utility poles as well as light poles, fire hydrants, sign poles, and other similar obstructions.

Table 3-3 Clearances to Structures and Obstructions

3.3.3 Standards for Grades

- **Minimum grades**

Flat and level grades on uncurbed pavements are acceptable when the pavement is adequately crowned to drain the surface laterally (see Chapter 4).

With curbed pavements, longitudinal grades should be sufficient to facilitate curb drainage. A minimum curb flowline grade for the usual case is 0.5 percent, but a grade of 0.30 percent may be used where there is a high type pavement adequately crowned and supported on firm subgrade. With curbed sections on sag vertical curves, a grade of at least 0.30 percent should be retained at the curb and gutter line by increasing the crown slope or, if necessary, shortening the vertical curve length to keep the crown slope from exceeding the maximum value given in Chapter 4.

- **Maximum grades**

The desirable maximum grades for the various functional classifications are shown in Table 3-4. The maximum design grade should be used infrequently; in most cases, grades should be less than the maximum design grade.

The term "critical length of grade" is used to indicate the maximum length of a designated upgrade upon which a loaded truck can operate without an unreasonable reduction in speed. On grades longer than "critical," consideration of extra lanes should be made (see section 3.3.5).

Type of Terrain	Maximum Grade (%) for Design Speed (mph)								
	20	30	40	45	50	55	60	70	80
RURAL AND URBAN FREEWAYS ^a [Exhibit 8-1 (1)]									
LEVEL				4 ^c	4 ^c	4 ^c	3 ^c	3	3
ROLLING				5 ^c	5 ^c	5 ^c	4 ^c	4	4
MOUNTAINOUS				6 ^c	6	6	6	5	--
RURAL ARTERIALS [Exhibit 7-2 (1)]									
LEVEL			5 ^c	5 ^c	4 ^c	4 ^c	3	3	3
ROLLING			6 ^c	6 ^c	5	5	4	4	4
MOUNTAINOUS			8	7	7	6	6	5	5
URBAN ARTERIALS [Exhibit 7-10 (1)]									
LEVEL		8	7	6	6	5	5		
ROLLING		9	8	7	7	6	6		
MOUNTAINOUS		11	10	9	9	8	8		
RURAL COLLECTORS ^b [Exhibit 6-4 (1)]									
LEVEL	7 ^c	7 ^c	7	7	6	6	5		
ROLLING	10 ^c	9	8	8	7	7	6		
MOUNTAINOUS	12	10	10	10	9	9	8		
URBAN COLLECTORS ^b [Exhibit 6-8 (1)]									
LEVEL	9 ^c	9	9	8	7	7	6		
ROLLING	12 ^c	11	10	9	8	8	7		
MOUNTAINOUS	14 ^c	12	12	11	10	10	9		
LOCAL RURAL ROADS [Exhibit 5-4 (1)]									
LEVEL	8 ^d	7	7	7	6	6	5		
ROLLING	11	10	10	9	8	7	6		
MOUNTAINOUS	16	14	13	12	10	10	--		
^a Grades one percent steeper than the value shown may be provided in mountainous terrain or in urban areas with crucial right of way controls.									
^b Maximum grades shown for rural and urban collector conditions of short lengths (less than 500 feet) and on one-way down grades may be two percent steeper.									
^c Design speed shown not recommended (less than minimum).									
^d Use only on urban streets.									

Table 3-4 Relation of Maximum Grades to Design Speed

3.3.4 Vertical Curves

Properly designed vertical curves should provide adequate sight distance, safety, comfortable driving, good drainage, and pleasing appearance.

Vertical curves are parabolic. Figure 3-14 gives the necessary mathematical relations for computing a vertical curve, at either crests or sags.

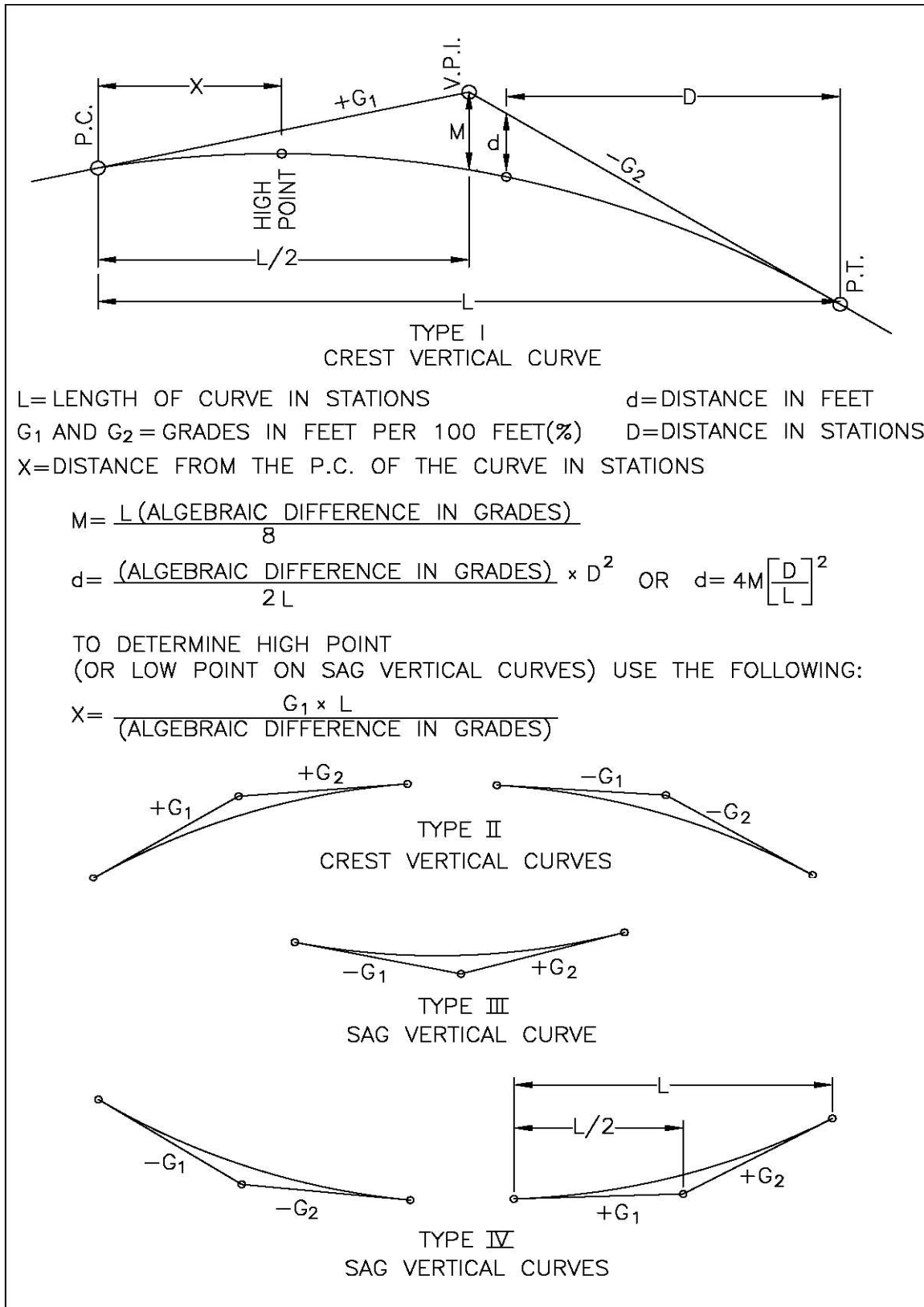

Figure 3-14 Vertical Curves

Minimum lengths of crest vertical curves are controlled by stopping sight distance requirements (see Table 3-1 and section 3.1.5.1).

Minimum lengths of sag vertical curves are controlled by headlight sight distance and should be nearly the same as stopping sight distance.

Vertical curves are not required where algebraic grade difference is less than 0.20 percent. In rural applications, the minimum length of vertical curves on main roadways, both crest and sag, should be 300 feet. For other applications, the minimum length should be about three times the design speed.

Vertical curves that have a level point and flat sections near their crest or sag should be evaluated for drainage where curbed pavements are used. Values of $K = 167$ ($K=L/A$ where L is the length of curve in feet, and A is the algebraic difference in grade) or greater should be checked for drainage. K value is a coefficient by which the algebraic difference in grades (A) may be multiplied to determine the length in feet (L) of the vertical curve that will provide minimum sight distance.

Also vertical curves that are long and flat may develop poor drainage at the level section. This difficulty may be overcome by adjusting the flow line of the ditch section.

3.3.5 Climbing Lanes

On long, steep grades, a climbing lane for the slow moving vehicles may be required. Criteria for establishing the need for such lanes are usually based on traffic volume, capacities, percent of trucks, grades, speeds, and level of service. Because of many variables, no set of conditions can be properly described as typical. A detailed analysis should be made wherever climbing lanes are being considered. A discussion of the analytical approach to be followed is presented in the *PGDHS(1)*.

The following three criteria, reflecting economic considerations, should be satisfied to justify a climbing lane:

1. Upgrade traffic flow in excess of 200 vehicles per hour.
2. Upgrade truck flow rate in excess of 20 vehicles per hour.
3. One of the following conditions exist:
 - A 10 mph or greater speed reduction is expected for a typical heavy truck.
 - Level-of-service E or F exists on the grade.
 - A reduction of two or more levels of service is experienced when moving from the approach segment to the grade.

The width of the climbing lane should be the same width as the regular traffic lanes. The beginning of the climbing lane should be preceded by a tapered section with a taper ratio of 25:1, and at least 150 feet long.

Desirably, the shoulder on the outer edge of a climbing lane should be as wide as the shoulder on the normal two-lane section. Conditions, however, may dictate otherwise, particularly when the climbing lane is added to an existing highway. A usable shoulder of 4 feet wide or greater is acceptable.

The ideal design would be to extend the climbing lane to a point beyond the crest, where a typical truck could attain a speed that is within 10 mph of the speed of the other vehicles with the desirable speed being at least 40 mph, approximately at level of service D. Even this may not be practical in many instances because of the unduly long distance required for trucks to accelerate to the desired speed. For such a condition, a practical point to end the added lane is where the truck can return to the normal lane without undue hazard. In particular, this would be feasible where the sight distance becomes sufficient to permit passing with safety when there is no oncoming traffic or, preferably at least 200 feet beyond this point. In addition, a corresponding length of taper should be provided to permit the truck to return to the normal lane.

For example, on a highway where the safe passing sight distance becomes available 100 feet beyond this point, the truck lane should extend 100 feet:

- Plus 200 feet or 300 feet beyond the crest,
- Plus an additional length for taper, preferably at a ratio of 50:1 but with a taper length of at least 200 feet.

Exhibits 3-59 and 3-60 (1) show the relationship between rate and length of grade for several reductions in speed. The 10 mph speed reduction curve is used as the design guide.

The method for determining passing lane location is described on page 246 of the *PGDHS* (1).

On steep two-lane downgrades, where trucks must reduce their speeds substantially below those of passenger cars, it may be desirable to provide an additional lane.

3.3.6 Passing Lanes

Passing lanes can be added on two-lane highways to improve traffic operation on sections of lower capacity and on lengthy sections (6 to 60 miles) where there are inadequate passing opportunities.

The logical location for a passing lane is where passing sight distance is restricted, but adequate sight distance should be provided at both the add and drop lane tapers. A minimum sight distance of 1000 feet on the approach to each taper is recommended. The selection of the location should consider the location of intersections and high volume driveways as well as physical constraints such as bridges and culverts that could restrict provision of a continuous shoulder.

Use the following design procedure to identify the need for passing sections on two-lane highways:

1. Design horizontal and vertical alignment to provide as much of the highway as practical with passing sight distance. See Passing Sight Distance column in Table 3-1.
2. Where the design volume approaches capacity, recognize the effect of lack of passing opportunities in reducing the level of service.
3. Determine the need for climbing lanes.
4. Where the extent and frequency of passing opportunities made available by application of Criteria 1 and 3 are still too few, consider the construction of passing lane sections.

Passing lane sections should be sufficiently long to permit several vehicles in a line behind a slow moving vehicle to pass before returning to the normal cross-section of two-lane highway. The minimum length, excluding tapers, should be 1000 feet. A lane added to improve overall traffic operations should be long enough, over 0.3 mile, to provide a substantial reduction in traffic platooning.

The transition tapers at each end of the added lane section should be designed to encourage safe and efficient operation. The lane drop taper should be computed from the MUTCD (2) formula: $L=WS$ where L =length in feet, W =width in feet, and S =speed in mph. The recommended length for the lane addition taper is half to two-thirds of the lane drop length. The transitions should be located where the change in width is in full view of the driver.

3.3.7 Turnouts

It will not always be economically feasible to provide passing lanes or desirably wide shoulders continuously along the highway through deep rock cuts or where other conditions limit the cross section width. In such cases, consideration should be given to use of intermittent sections of shoulder or turnouts along the highway. Such turnouts provide an area for emergency stops and also allow slower moving vehicles to pull out of the through lane to permit following vehicles to pass.

Turnouts should be located so that approaching drivers will have a clear view of the entire turnout in order to determine whether the turnout is available for use. Consider sight distance for vehicles re-entering the road. Refer to Exhibit 3-64 (1) for recommended lengths of turnouts including taper.

3.4 COMBINATION OF HORIZONTAL AND VERTICAL ALIGNMENT

To avoid the possibility of introducing serious hazards, coordination is required between horizontal and vertical alignment. Particular care must be exercised to maintain proper sight distance. Where grade line and horizontal alignment will permit, it is desirable to superimpose

vertical curves on horizontal curves. This reduces the number of sight distance restrictions and makes changes in the profile less apparent, particularly in rolling country. Care should be taken, however, not to introduce a sharp horizontal curve near a pronounced summit or grade sag. This is particularly hazardous at night.

Horizontal curvature and profile grade should be made as flat as possible at highway intersections.

On divided highways, variation in the width of median and the use of separate profiles and horizontal alignment should be considered to derive the design and operational advantages of one-way roadways.

For additional information, see General Design Controls and Exhibit 3-77 (1).

3.5 GUIDELINES FOR DESIGNING DETOURS

For the purpose of applying these guidelines, a detour is any temporary routing of traffic off its usual course, including the use of existing alternate routes or use of modified lane widths on the main roadway.

The following criteria guidelines are recommended when designing a detour. Items are those which must be addressed when requesting detour approval. This is not a design policy and circumstances may often justify departure from these guidelines. For further reference, see the CDOT Form 518.

3.5.1 Detour Design Speed

The design speed of a detour should be as close to the mainline operating speed as possible. Every effort should be made keep the speed differential within 10 mph so as not to affect the capacity, although in some cases a maximum of 15 mph or more may be considered. As truck traffic increases so should the emphasis on providing the lowest possible speed differential. An exception may be posted city streets. See section 3.5.7.

3.5.2 Detour Clear Zone

Use the criteria corresponding to the speed, geometry, and traffic of the existing highway for designing the detour. Detour culverts should be included in the clear zone analysis.

Portable barrier may often be the most cost effective method of resolving detour clear zone problems.

3.5.3 Detour Typical Section

- **Lane Width**

It is desirable to maintain the width of the main roadway, but if this is not practical, the following guidelines apply:

A minimum lane width of 10 feet may be used if all of the following conditions are satisfied:

- The truck annual average daily traffic (AADT) is less than 50.
- The design speed is ≤ 45 mph.
- No curves are greater than 7 degrees.

If one or more of the above conditions fails, 11-foot or wider lanes should be used.

If any of the following conditions apply, 12-foot lanes should be used:

- Design speed of 55 mph or more.
- The truck AADT is greater than 300.
- The road is an arterial or on an arterial truck network system.

If main roadway lanes are 11 feet, the detour may retain 11-foot width.

- **Shoulder Width**

Desirable shoulder width is 4 feet. Two feet minimum is required.

3.5.4 Detour Barrier

Barrier will be required when any hazards exist within the clear zone including drop-offs or steep slopes. It may also be required for the protection of workers. Shoulder Dropoffs 3 inches or greater shall be mitigated within 24 hours.

When barrier is used it shall be installed at least 2 feet offset from edge of pavement with an appropriate distance from back of barrier to obstruction; see M & S Standards. If shoulders are not provided, it shall be installed 2 feet from the edge of the traveled lane. Where the situation allows, an offset of 4 feet from the traveled lane should be provided.

3.5.5 Detour Surfacing

An asphalt surface is usually functionally superior to gravel, although gravel may have economic and other advantages. Asphalt should be used if detour speed is over 40 mph or the detour will be used for three weeks or more. Consult Region Materials Engineer for detour pavement design. Refer to the *Project Development Manual (9)* for additional information.

3.5.6 Detour Superelevation

Figure 3-15 gives the rate of superelevation to be used on detours during construction of culverts, bridge replacement or widening, or repairs when proper construction signing is in place.

The formula shown in Figure 3-15 is the same as used in CDOT *Standard Plans - M & S Standards – Superelevation (3)*, which shows superelevation and curvature for various design speeds, except that the "e" value shown in CDOT *Standard Plans - M & S Standards* is based on maximum driving comfort and safety, combined with a widely variable friction factor caused by adverse pavement surface and weather conditions.

By use of Figure 3-15 the designer can choose a combination of friction factor, superelevation, and curvature to meet required design speed without the necessity of building up an excessive amount of superelevation and runoff which must be removed after a short time.

Values on Figure 3-15 have been checked by the "Ball Bank Indicator" to determine the point of discomfort for safe speeds on curves.

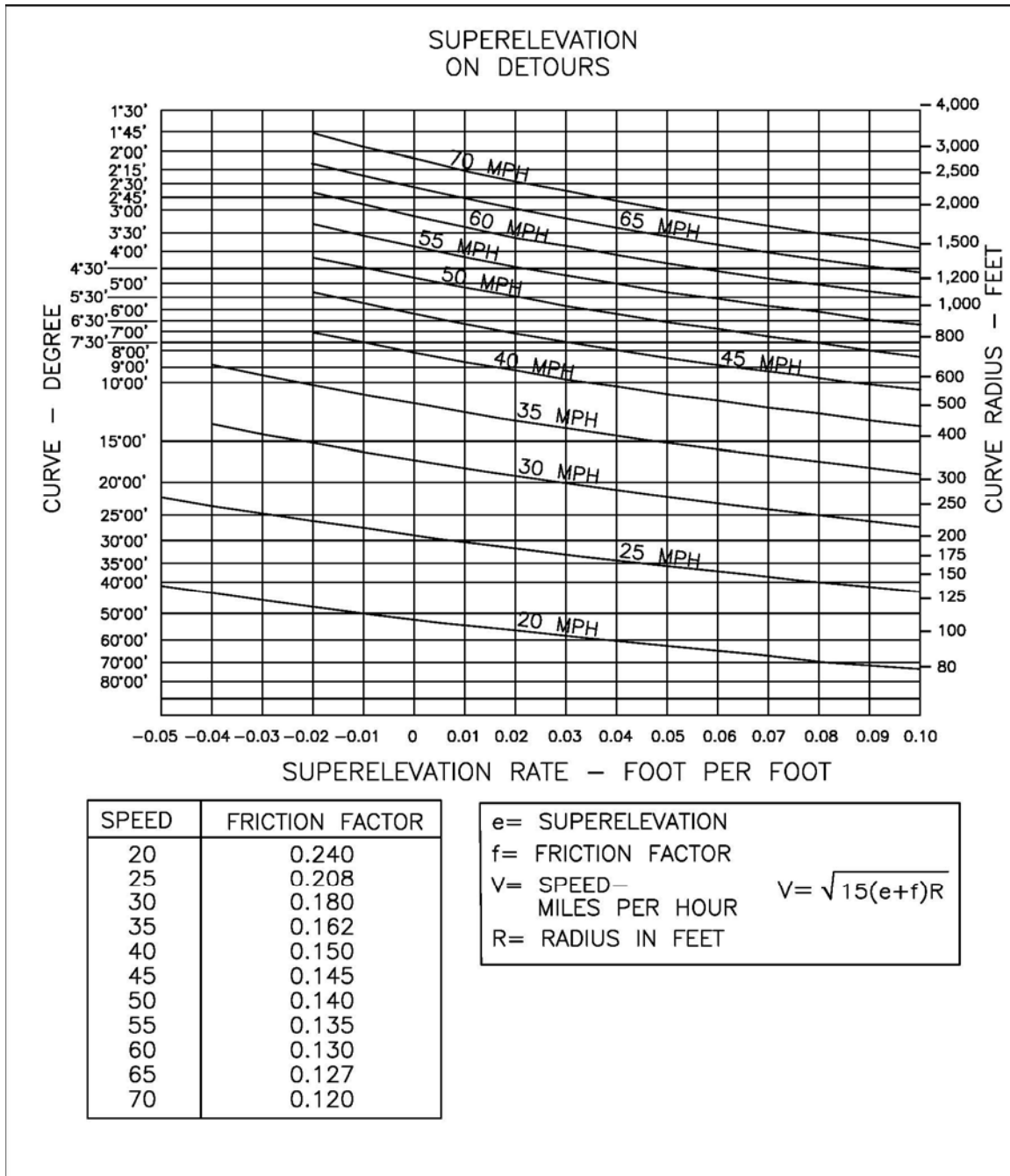

Figure 3-15 Superelevation on Detours

3.5.7 Detour on Local Roads

When local roads are used in detour routing, the stabilization needs must be reviewed. If necessary, additional overlay should be placed to protect the structural integrity of the street.

All the above-listed design elements, including the information on "Detour Design Data," shall be specified in the plans.

The following should be considered:

- Inter-Governmental Agreement
- Weight Limits
- Noise
- Traffic
- Schools

3.5.8 Environmental Considerations for Detours

When designing detours, it is important to consider and mitigate any possible environmental impacts. These can include wetlands, archaeology or paleontology resources, hazardous waste, water quality or 4(f) involvement. These impacts may be avoided by the proper placement of the detour. For assistance in evaluating possible impacts, contact the Region Planning/Environmental Section

3.5.9 Detour Transverse Underdrains

Transverse underdrains are those constructed perpendicular to roadway. See the *CDOT Drainage Design Manual (10)*.

3.6 OTHER ELEMENTS AFFECTING GEOMETRIC DESIGN

3.6.1 Drainage and Erosion Control

Consider the following:

- Collect water prior to transitioning superelevations to prevent sheet flow.
- Design and locate inlets to limit the spread of water on the traveled way to tolerable widths.
- Install extra inlets near low points of sag vertical curves to take any overflow from blocked inlets.
- Locate inlets just upgrade of pedestrian crossings.
- Address environmental issues such as erosion and sediments.
- Dikes in medians and on the edge of the road should comply with clear zone requirements.
- Coordinate NPDES issues with Region Planning and Environmental Manager [see the *CDOT Project Development Manual (9)*].

Also see the *CDOT Drainage Manual (10)*.

3.6.2 Rest Areas

Coordinate with the FHWA operations engineer. Refer to the AASHTO *Guide for Development of Rest Areas on Major Arterials and Freeways (11)* and Colorado Rest Area Management & Maintenance Study".

3.7 LIGHTING

Consider the following:

- Coordinate with the Region Utility Engineer and the local utility company.
- Minimize light pollution in conformance with 24-82-902 Colorado Revised Statutes (CRS).
- Safety enhancement.

3.8 UTILITIES

Consider the following:

- Coordinate with the Region Utilities Engineer early and throughout the design process.
- Pothele to locate utilities as practical.
- Plot existing utilities in plan, profile, and cross sections to identify potential conflicts with design elements.
- Utility Notification Center of Colorado will not locate CDOT owned utilities; contact the Region Traffic Signal Supervisor.
- Utility relocation requirements should be compatible with construction phasing.
- An Inter-Governmental Agreement (IGA) may be necessary.

The clear zone dimensions to be maintained for a specific functional classification are discussed in the section on "Horizontal Clearance to Obstructions" in Chapter 4 of the *PGDHS (1)*.

Utilities that are to cross or otherwise occupy the right of way of rural or urban freeways should conform to the AASHTO *Policy on the Accommodation of Utilities Within Freeway Right-of-Way (12)*. Those on non-controlled access highways and streets should conform to the AASHTO *Guide for Accommodating Utilities Within Highway Right-of-Way (13)*.

3.9 TRAFFIC CONTROL DEVICES

The development of traffic control plans is an essential part of the overall project design and may affect the design of the facility itself. See Chapter 20, "Safety and Traffic Engineering" and the *MUTCD (2)*.

3.10 NOISE BARRIERS

See Chapter 18.

REFERENCES

1. AASHTO. *A Policy on Geometric Design of Highways and Streets*, American Association of State Highway and Transportation Officials, Washington, D.C.: 2004.
2. U.S. Department of Transportation, Federal Highway Administration, *Manual on Uniform Traffic Control Devices for Streets and Highways (MUTCD)*, Washington, D.C.: 2000.
3. CDOT. *CDOT Standard Plans - M & S Standards*. Colorado Department of Transportation, 2000.
4. Hickerson, Thomas F., *Route Location and Design*, McGraw-Hill Book Company, New York, N.Y., 1964.
5. AASHTO. *Standard Specifications for Structural Supports for Highway Signs, Luminaires, and Traffic Signals*, American Association of State Highway and Transportation Officials, Washington, D.C.: 1994.
6. AASHTO. *Roadside Design Guide*. American Association of State Highway and Transportation Officials, Washington, D.C.: 2002.
7. AASHTO. *Standard Specifications for Highway Bridges*, Washington, D.C.: American Association of State Highway and Transportation Officials, 1996.
8. CDOT *Bridge Design Manual*. Colorado Department of Transportation, 2002.
9. CDOT *Project Development Manual*. Colorado Department of Transportation, 2001.
10. CDOT *Drainage Design Manual*. Colorado Department of Transportation, 2003.
11. AASHTO. *Guide for Development of Rest Areas on Major Arterials and Freeways*. American Association of State Highway and Transportation Officials, Washington, D.C.: 2001.
12. AASHTO. *A Policy on the Accommodation of Utilities Within Freeway Right-of-Way*. American Association of State Highway and Transportation Officials, Washington, D.C.: 1989.
13. AASHTO. *A Guide for Accommodating Utilities Within Highway Right-of-Way*. American Association of State Highway and Transportation Officials, Washington, D.C.: 1994.

