

**Report No. CDOT-2010-7  
Final Report and Addendum**

---



## **BIRD NESTING AND DROPPINGS CONTROL ON HIGHWAY STRUCTURES**

**D. Jean Tate, Ph.D.**

**October 2010**

**COLORADO DEPARTMENT OF TRANSPORTATION  
APPLIED RESEARCH AND INNOVATION BRANCH**

The contents of this report reflect the views of the author(s), who is(are) responsible for the facts and accuracy of the data presented herein. The contents do not necessarily reflect the official views of the Colorado Department of Transportation or the Federal Highway Administration. This report does not constitute a standard, specification, or regulation.

Technical Report Documentation Page

1. Report No. CDOT-2010-7	2. Government Accession No.	3. Recipient's Catalog No.	
4. Title and Subtitle BIRD NESTING AND DROPPINGS CONTROL ON HIGHWAY STRUCTURES		5. Report Date October 2010	
		6. Performing Organization Code	
7. Author(s) D. Jean Tate, Ph.D.		8. Performing Organization Report No. CDOT-2010-7	
9. Performing Organization Name and Address Enviro-Support, Inc. 7485 Quartz Street Arvada, CO 80007		10. Work Unit No. (TRAIS)	
		11. Contract or Grant No. 41.76	
12. Sponsoring Agency Name and Address Colorado Department of Transportation - Research 4201 E. Arkansas Ave. Denver, CO 80222		13. Type of Report and Period Covered Final (through December 2009) and Addendum (December 2009 through October 2010)	
		14. Sponsoring Agency Code	
15. Supplementary Notes Prepared in cooperation with the US Department of Transportation, Federal Highway Administration			
16. Abstract: This report provides a comprehensive literature survey of permanent and temporary deterrents to nesting and roosting, a discussion of risks to human health and safety from exposure to bird nests and droppings and recommended protective measures, and the results of a multi-year field study to test temporary nesting deterrents judged to be most effective.  An extensive survey of the literature was conducted on the following: <ul style="list-style-type: none"> <li>• measures used to deter roosting and nesting of pigeons, temporarily deter nesting of swallows (primarily cliff and barn swallows);</li> <li>• the nesting requirements of these species to better enable evaluation of the efficacy of these measures; and</li> <li>• the biology, diseases, and parasites of these species to enable evaluating and minimizing the risks of human detriment from exposure to these birds, their nests and droppings.</li> </ul> Implementation: The most effective methods to deter pigeon roosting/nesting are either physical deterrents (i.e., spikes, wires, corner slopes, and netting) or non-toxic chemical methods. The most effective deterrents for swallow nesting are corner slopes, hanging curtains, and netting. For any of these methods, proper installation and maintenance are the keys to success. Consideration should be given to the configuration of the specific site, the extent of the problem, and the cost-effectiveness of the method relative to the extent of the problem.			
17. Keywords: pigeons, swallows, bird nesting deterrents, bird roosting deterrents, bird droppings, bridges, human health risks		18. Distribution Statement No restrictions. This document is available to the public through the National Technical Information Service <a href="http://www.ntis.gov">www.ntis.gov</a> or CDOT's Research Report website <a href="http://www.coloradodot.info/programs/research/pdfs">http://www.coloradodot.info/programs/research/pdfs</a>	
19. Security Classif. (of this report) None	20. Security Classif. (of this page) None	21. No. of Pages 144	22. Price

# BIRD NESTING AND DROPPINGS CONTROL ON HIGHWAY STRUCTURES

Prepared by:  
D. Jean Tate  
Enviro-Support, Inc.  
303-403-4748  
7485 Quartz Street  
Arvada, CO 80007

Report Number CDOT-2010-7

Sponsored by the:  
Colorado Department of Transportation  
In Cooperation with the:  
U.S. Department of Transportation  
Federal Highway Administration

October 2010

Colorado Department of Transportation  
DTD Applied Research and Innovation Branch  
4201 East Arkansas Avenue  
Denver CO 80222

## ACKNOWLEDGMENTS

Most members of the Study Panel attended the several meetings of the Study Panel and contributed their ideas and support to this project. In addition, several Study Panel members attended the initial Field Visit and/or participated in deterrent installation. Several also provided support via email and/or phone discussions, as follows:

- A phone discussion with Rob Haines provided helpful information regarding concerns associated with cleaning CDOT bridges; the types of activities maintenance, engineering, and inspection personnel are most often involved in; and the type of information needed relative to human health and safety concerns. Rob Haines also provided information about the installation and maintenance of the overpass at Broadway and Hampden that we visited during the field trip.
- Russ Cox mentioned a design change in an email and phone conversation.
- Jeff Anderson provided some photos of CDOT structures where pigeon roosting/nesting was a problem and engaged in a brief email exchange. He also provided suggestions for bridge design changes.
- Debra Angulski provided information on an innovative bridge design used in the past by CDOT to deter pigeon roosting.
- Jeff Peterson supported this project repeatedly in the field, helping to knock down swallow nests prior to deterrent installation and to get the numerous installation materials to the field as well as deliver left over materials to CDOT storage areas.

Also, Trevor Wang (CDOT Bridge Unit Leader, Regions 1 and 5) and Dick Osmun (CDOT Bridge Unit Leader, Region 4) were most helpful in brainstorming ideas regarding future bridge design changes that would exclude pigeons. They provided excellent ideas on the pros and cons of various design components. In addition, George Tsiouvaras, currently of Tsiouvaras Simmons Holderness, provided the schematic of the modified precast concrete girder used on I-70, as well as ideas on the pros and cons of such a structure.

In addition, Region 4 Maintenance staff (Al Roys [TM-III, Mead]; Randy Dreiling [TM-II, Superior]; Bob Northrope [TM-I, Superior]; Carlos Carrillo [TM-I, Superior]; Dale Steerman [TM-I, Superior]; Robert Aragon [TM-I, Superior]; Paul Guajardo [TM-II, Boulder]; Dan Catalano [TM-I, Boulder]; Chuck Jett [TM-I, Longmont]; Glenn Tomchek [TM-I, Longmont]; Scott Klemm [TM-I, Longmont]; John Leroux [TM-I, Mead]; Jim Hamrick [TM-I, Mead]; and Leroy Martinez [TM-I, Mead]) provided excellent support during the installation of the deterrents in the field. Even though this project is sponsored by CDOT Headquarters and its findings will benefit CDOT maintenance staff throughout the state, it was Region 4 who came out twice (!!!) to work on field installation. Phillip Anderle, Christian Kelly, and Dennis Allen were particularly gracious in lending their staff to us. In addition, Pat Martinek (HG Research and Innovation Branch-Environmental); Jeff Peterson (Environmental Programs Branch); Alison Deans-Michael (U.S. Fish and Wildlife Service); and Jim Eussen, Myron Hora, Carol Parr, Karen Schneiders, and Kathy Seelhof (Region 4 Environmental) also helped during field installation. It was a job well done with enthusiasm, problem-solving, teamwork, and

successful installation. A huge THANK YOU is due to all of the above individuals, each of whom contributed greatly to this project. A number of those mentioned went far beyond the call of duty to make this project a success.

Finally, considerable thanks should go to Ron Jones and the City and County of Broomfield for allowing this study of swallow deterrents to take place in concrete box culverts (CBCs) under their purview. These CBCs were easy to access and greatly facilitated this project. By graciously allowing this project to continue beyond the timeframe originally envisioned, Ron Jones and the City and County of Broomfield enabled considerably more information to be gathered from the study.

## EXECUTIVE SUMMARY

This report provides a comprehensive literature survey of permanent and temporary deterrents to nesting and roosting, a discussion of risks to human health and safety from exposure to bird nests and droppings and recommended protective measures, as well as the results of a multi-year field study to test temporary nesting deterrents judged to be most effective.

The extensive survey of the literature was conducted on the following:

- measures used to deter roosting and nesting of pigeons, temporarily deter nesting of swallows (primarily cliff and barn swallows);
- the nesting requirements of these species to better enable evaluation of the efficacy of these measures; and
- the biology, diseases, and parasites of these species to enable evaluating and minimizing the risks of human detriment from exposure to these birds, their nests and droppings.

Ultimately, the most effective methods to deter pigeon roosting/nesting are either physical deterrents (i.e., spikes, wires, corner slopes, and netting), or non-toxic chemical methods (i.e., methyl anthranilate). For any of these methods, proper installation and maintenance are key to their success. The most appropriate of these methods depends on the configuration of the specific site, the extent of the problem, and the cost-effectiveness of the method relative to the extent of the problem. Ultimately, the most effective methods to be used to deter swallow nesting are also either physical deterrents or non-toxic chemical methods. The above comments on proper installation/maintenance and on site-specific conditions are important here as well. The methods recommended as most effective deterrents for swallow nesting are corner slopes, hanging curtains, and netting.

In the field study, three temporary deterrents to swallow nesting were installed in three separate concrete box culverts (CBCs) starting on March 18, 2008. These CBCs are within the City and County of Broomfield, which graciously gave permission for the conduct of this study. A fourth CBC was used as a control. The three temporary deterrents installed were corner slope, hanging curtain, and paint as follows: two types of corner slopes were tested (a Bird Slide product and a constructed corner slope) on opposite sides of one CBC; two colors of 24-inch-wide plastic sheeting (clear and black) were installed on opposite sides of one CBC as solid sheets and as 2-inch wide vertical strips; one third of the ceiling of one CBC was painted blue with a cement paint. These CBCs were visited fifteen times between April 16 and June 4th, 2008. No nesting occurred in any of the test CBCs or the control CBC during 2008. However, hundreds of swallows nested in a nearby CBC under Midway Boulevard to the east of the test CBCs.

The deterrents were left in place through the winter and the following spring and summer (2009). They were checked once in each of four months—January, April, May, and August. The survey in August revealed that cliff swallows (and one pair of Say's phoebes) had moved into the CBC where corner slopes were tested and occupied spaces

where the deterrents had blown down. There were 45 completed nests on the north side of this CBC where many of the Bird Slide corner slopes had been, and 3 completed nests on the south side where part of the constructed corner slope had been. There were no nests in any of the other test CBCs or in the control CBC. Large numbers of swallows were again nesting in the Midway Boulevard CBC in 2009.

Given the results obtained in the summer of 2009, it was decided to leave the deterrents in place for another year to see if more swallows move into the test CBCs. Information from the 2010 project extension was included in a brief Addendum Report, which is included as Appendix A.



# TABLE OF CONTENTS

<b>1.0 INTRODUCTION .....</b>	<b>1</b>
<b>1.1 Survey.....</b>	<b>1</b>
<b>1.2 Permanent Pigeon Roosting/Nesting Deterrents and Temporary Migratory     Bird Nesting Deterrents.....</b>	<b>8</b>
<i>1.2.1 Additional Comments on Permanent Pigeon Roosting/Nesting Deterrents.....</i>	<i>71</i>
<i>1.2.2 Additional Comments on Temporary Migratory Bird Nesting Deterrents.....</i>	<i>71</i>
<b>1.3 Investigate Other Options to Minimize CDOT Personnel Exposure.....</b>	<b>71</b>
<i>1.3.1 Consultation with Study Panel.....</i>	<i>71</i>
<i>1.3.2 Field Visit.....</i>	<i>72</i>
<i>1.3.3 Risks to Human Health and Safety .....</i>	<i>73</i>
<i>1.3.4 Protective Measures .....</i>	<i>75</i>
<b>1.4 Interviews of Bridge Personnel and Engineers Regarding Design Change     Options to Prevent/Discourage Roosting/Nesting in Bridge Structures .....</b>	<b>75</b>
<i>1.4.1 Elimination of Appropriate Sites for Nesting/Roosting .....</i>	<i>76</i>
<i>1.4.2 Preventing Access to Structural Members.....</i>	<i>78</i>
<b>1.5 Describe New Bridge Design Techniques Being Employed or Proposed by     CDOT.....</b>	<b>80</b>
<b>1.6 Devise and Conduct Field Experiments of Best Options to Deter Nesting.....</b>	<b>82</b>
<b>2.0 RESULTS AND DISCUSSION .....</b>	<b>88</b>
<b>3.0 CONCLUSIONS .....</b>	<b>106</b>
<b>4.0 REFERENCES .....</b>	<b>108</b>
<b>APPENDIX A – ADDENDUM REPORT.....</b>	<b>A-1</b>
<b>APPENDIX B – INFORMATION SHEET TO GUIDE WORKERS IN CLEANING UP PIGEON DROPPINGS AND NEST DEBRIS.....</b>	<b>B-1</b>
<b>APPENDIX C – SAFE OPERATING GUIDE.....</b>	<b>C-1</b>

## LIST OF TABLES

Table 1. Internet Search Words. ....	2
Table 2. Individuals Contacted for Interviews.....	3
Table 3a. Criteria for Pigeon Dropping/Nesting Solutions – Chemical. ....	10
Table 3b. Criteria for Pigeon Dropping/Nesting Solutions – Coatings. ....	18
Table 3c. Criteria for Pigeon Dropping/Nesting Solutions – Other.....	24
Table 3d. Criteria for Pigeon Dropping/Nesting Solutions – Spikes/Wires.....	26
Table 3e. Criteria for Pigeon Dropping/Nesting Solutions – Corner Slope/Netting. ....	30
Table 3f. Criteria for Pigeon Dropping/Nesting Solutions – Removal by Predators/Trapping.....	36
Table 3g. Criteria for Pigeon Dropping/Nesting Solutions – Removal by Shooting/Egg Removal.....	43
Table 3h. Criteria for Pigeon Dropping/Nesting Solutions – Removal by Nest Removal/Food Removal. ....	44
Table 3i. Criteria for Pigeon Dropping/Nesting Solutions – Scare by Static and Moving Figures.....	45
Table 3j. Criteria for Pigeon Dropping/Nesting Solutions – Scare by Noises.....	48
Table 4a. Criteria for Temporary Swallow Nesting Solutions – Chemical. ....	49
Table 4b. Criteria for Temporary Swallow Nesting Solutions – Coatings.....	53
Table 4c. Criteria for Temporary Swallow Nesting Solutions – Other. ....	57
Table 4d. Criteria for Temporary Swallow Nesting Solutions – Netting/Curtain. ....	59
Table 4e. Criteria for Temporary Swallow Nesting Solutions – Corner Slope/Spikes. ....	65
Table 4f. Criteria for Temporary Swallow Nesting Solutions – Nest Removal. ....	70
Table 5. 2008 Swallow Deterrent Data Sheets. ....	89
Table 6. 2009 Swallow Deterrent Data Sheets. ....	96

## LIST OF FIGURES

Figure 1. Pier 4 Joint Support Beam at Girder A (E16ND).....	78
Figure 2. Bridge in Brisbane, Australia. ....	78
Figure 3. 3-Inch Gap in Splice in Gir 5A (E16ND).....	79
Figure 4. Pigeon Feces in Gir 5a Where Pigeons Entered Through 3-Inch Gap. ....	79

Figures 5 and 6. The Underside of I-70 in the Vicinity of the Coliseum Showing Precast Concrete Girders with a Built-in Corner Slope.....	80
Figure 7. Schematic Diagram of a Precast Concrete Girder That Incorporates a Corner Slope.....	81
Figures 8 / 9. The Underside of I-70 Showing an Old Poured In Place Concrete Structure That Effectively Deters Pigeon Nesting/Roosting, but Deteriorates over Time.....	82
Figure 10. CBCs Used in Field Test .....	83
Figure 11. Looking East from Within CBC 1 (Southernmost) with Blue Ceiling. ....	84
Figure 12. Looking West in CBC 2 with Plastic Strips Installed. ....	85
Figure 13. Looking West in CBC 3 Used as a Control.....	85
Figure 14. Looking West in CBC 4 with Corner Slope Deterrents in Place. ....	87
Figure 15. Looking West with Swallows.....	95
Figure 16. Active Swallow Nests in Fifth CBC.....	95
Figure 17. Bird Slide Panels and White Plastic Panels Collected after December 2008 Wind Storm. ....	99
Figure 18. Corner Slope Status after December 2008 Wind Storm.....	99
Figure 19. Status of Plastic Strip Deterrents After December 2008 Wind Storm. ....	100
Figure 20. Looking West Down CBC4 from the CBC Entrance On August 18, 2009. ..	100
Figure 21. Looking West Down CBC 4 from Within the CBC on August 18, 2009. ....	101
Figure 22. The Two Screws That Kept the White Plastic Panel in CBC 4 from Falling Out Completely .....	101
Figure 23. How the White Plastic Panel Was Held into the Metal Grooves in CBC 4. ..	102
Figure 24. The North Side of CBC 4 Showing the Space West of the Last Bird Slide Panel and the Nests Near the West End of the CBC.....	102
Figure 25. The North Side of CBC 4 Showing a Closer View of the Nests near the West End of the CBC.....	102
Figure 26. Nest of Say's Phoebe on Top of Triangular Bird Slide Attachment.....	103
Figure 27. Swallow Nests on the South Side of CBC 4 in the Space Where White Plastic Panels Had Fallen Down.....	103
Figure 28. The Status of the Blue Paint in CBC 1 on August 18, 2008. ....	104
Figure 29. The Status of The Plastic Strips in CBC 2 on August 18, 2008.....	104
Figure 30. Nests in The Non-Test CBC Under Midway Boulevard Showing Their Density and the Whitewash at Their Entrances.....	104

## **1.0 INTRODUCTION**

The following is a Final Report prepared for the Colorado Department of Transportation (CDOT): Bird Nesting and Droppings Control on Highway Structures, Study No: 41.76. Per specifications of the Statement of Work (SOW), this Final Report includes a summary of progress as of December 31, 2009 on the Tasks in the SOW. The organization of this Final Report is based on these Tasks. Implementation of the Tasks was guided by a CDOT Study Panel as discussed below.

Note that the swallow deterrents discussed below have not been removed as of the date of this Final Report. Any subsequent observations of note on these deterrents have been included in a brief Addendum Report, which is attached as Appendix A.

### **1.1 Comprehensive Literature Survey**

An extensive survey of the literature was conducted on the following:

- measures used to deter roosting and nesting of pigeons, temporarily deter nesting of swallows (primarily cliff and barn swallows);
- the nesting requirements of these species to better enable evaluation of the efficacy of these measures; and
- the biology, diseases, and parasites of these species to enable evaluating and minimizing the risks of human detriment from exposure to these birds, their nests and droppings.

Table 1 contains a list of internet search terms that were used to initiate each search. Often, during a given search, subsequent threads of information were pursued to fully explore information about the search term.

**Table 1. Internet Search Words.**

sense of smell, birds slippery surface coating, metal ornithosis birdslide	bird flu journal of wildlife management H1N5 West Nile Virus
pigeon nesting pigeon peregrine bridge pigeon peregrine pigeon nesting requirements pigeon disease diseases caused by pigeons	pigeon control pigeon lofts ectoparasites pigeon pigeon control advisory service pigeon droppings USDA APHIS pigeon
swallow nesting strip doors swallow control swallow disease swallow nesting requirements diseases caused by swallows	ectoparasites swallow swallow droppings USDA APHIS swallow swallow bridge swallow nests

Information obtained during the online literature survey was downloaded and was included on a compact disc (CD) delivered to CDOT with the Interim Report for this project. Most of the information found in a PDF format was also summarized in an Excel spreadsheet, also included on the CD. In addition, several individuals who are or have been engaged in similar research were contacted to discuss their findings. People who served as sources of information are identified in Table 2. People who were on the Study Panel are also listed on this table, separately from individuals who were contacted because they are/were/hope to be engaged in similar research. Emails received from these people were provided on the CD as text files.

Markedly diminished return on literature survey effort was experienced by the time the Interim Report was submitted and no further literature search was performed subsequently.

**Table 2. Individuals Contacted for Interviews.**

<b>Last Name</b>	<b>First Name</b>	<b>Affiliation</b>	<b>Phone</b>	<b>Email</b>	<b>Connection</b>	<b>Comment</b>
Martinek	Patricia	CDOT Research	303-757-9787	<a href="mailto:Patricia.Martinek@dot.state.co.us">Patricia.Martinek@dot.state.co.us</a>	Study Panel	
Anderson	Jeff	HQ Bridge Inspection Engineer	303-757-9188 303-947-0357	<a href="mailto:Jeffrey.Anderson@dot.state.co.us">Jeffrey.Anderson@dot.state.co.us</a>	Study Panel	
Angulski	Debra	R-1 Planning and Environmental	303-877-4056	<a href="mailto:Debra.Angulski@dot.state.co.us">Debra.Angulski@dot.state.co.us</a>	Study Panel	
Cox	Russell	R-1 Foothills Resident Engineer	303 829 2204	<a href="mailto:Russel.Cox@dot.state.co.us">Russel.Cox@dot.state.co.us</a>	Study Panel	
DeDios	Roberto	HQ Research	303-757-9975	<a href="mailto:Roberto.dedios@dot.state.co.us">Roberto.dedios@dot.state.co.us</a>	Study Panel	
Eussen	Jim	R-4 Planning	970-350-2168	<a href="mailto:James.Eussen@dot.state.co.us">James.Eussen@dot.state.co.us</a>	Study Panel	
Haines	Rob	R-6 Maintenance Superintendent	303-757-9514	<a href="mailto:Robert.Haines@dot.state.co.us">Robert.Haines@dot.state.co.us</a>	Study Panel	
Hann	Jane	R-6 Planning & Environmental	303-757-9397	<a href="mailto:Jane.Hann@dot.state.co.us">Jane.Hann@dot.state.co.us</a>	Study Panel	
Peterson	Jeff	HQ Environmental Programs Branch	303-512-4959	<a href="mailto:Jeff.Peterson@dot.state.co.us">Jeff.Peterson@dot.state.co.us</a>	Study Panel	
Talmadge	Gina	CDOT Citizen's Advocate	303-757-9485	<a href="mailto:Gina.Talmadge@dot.state.co.us">Gina.Talmadge@dot.state.co.us</a>	PR Contact	
Bergoti	Bruce	BirdTec	231-832-1943	<a href="mailto:bruce@birdtec.net">bruce@birdtec.net</a> ; <a href="http://www.birdtec.net">www.birdtec.net</a>	Mentioned by Debra Angulski	Concord grape product that acts like Mace on birds
Bryant	Clay	Citizen	765-557-0403	<a href="mailto:olclayfromnebr@yahoo.com">olclayfromnebr@yahoo.com</a>	Citizen contact	Suggested "Envirocoat" made by Blue River Coatings of Hastings, NE

Last Name	First Name	Affiliation	Phone	Email	Connection	Comment
Fuselier, P.E.	Carl J.	Assistant Division Head - Bridge Division, Arkansas Highway and Transportation Department	501-569-2361	<a href="mailto:Carl.Fuselier@arkansashighways.com">Carl.Fuselier@arkansashighways.com</a>	Source of Arkansas study on use of ultrasonic devices to deter swallow nesting	Study well done and shows that ultrasonic devices are not effective.
Gould	Richard	Citizen		<a href="mailto:richard.gould@gmail.com">richard.gould@gmail.com</a>	Citizen contact	Suggested naphthalene in empty soda bottle w/holes as deterrent to birds nesting on the outside of his house.
Harris	John	Assistant Division Head - Environmental Division, Arkansas Highway and Transportation Department	501-569-2285		Source of further information about the Arkansas study on use of ultrasonic devices to deter swallow nesting	
Jones	Ron	Public Works Department Public Works Department, City and County of Broomfield	303-464-5658	<a href="mailto:rjones@broomfield.org">rjones@broomfield.org</a>	Provided approval for use of Broomfield concrete box culverts (CBCs)	Needs to be contacted again in late spring 2010 to discuss whether deterrents need to be left in place through the 2010 breeding season to avoid disturbing

Last Name	First Name	Affiliation	Phone	Email	Connection	Comment
						nesting swallows, and a final time to be told that deterrent materials have been removed from CBCs (except for glued furring strips and paint, which can be left in place).
Linskens, P.E.	Jim	Rocky Mountain Prestress, Quality Assurance Engineer	303.964.7039	<a href="mailto:linskensj@rmpprestress.com">linskensj@rmpprestress.com</a>	Mentioned by Debra Angulski	Provided information on non-standard pour of concrete girders near Coliseum on I-70 and name of George Tsiouvaras as knowledgeable contact.
Mullori	Don	Analytical Services & Materials, VP, Business Development	757-865-7093x310	<a href="mailto:mullori@asm-usa.com">mullori@asm-usa.com</a>	Contacted CDOT after reading D. Post article	Protective coating that has a slick surface to prevent ice buildup and fouling by marine organisms
Slevin	Colleen	Associated Press-Denver	303-825-0123	<a href="mailto:cslevin@ap.org">cslevin@ap.org</a>		Provided newspaper article on pigeon droppings re St.Paul bridge
Tsiouvaras	George	Tsiouvaras Simmons Holderness	303-771-6200	<a href="mailto:george.tsiouvaras@tshengineering.com">george.tsiouvaras@tshengineering.com</a>	Involved in the design and construction of non standard cast concrete	Provided schematic design of non-standard concrete girders and excellent information on the pros and cons of their use.



Last Name	First Name	Affiliation	Phone	Email	Connection	Comment
					girders while working for Carter Burgess	
Allen	Dennis	Head of Maintenance, Region 4	(970) 350-2120		Mentioned by Jim Eussen	
Fisher	Gene	Bridge Maintenance, Region 4	(970) 587-5141		Mentioned by Jim Eussen	
Kelly	Christian	Bridge Maintenance, Region 4	303-546-5640 303-829-3088=cell		Mentioned by Dennis Allen and Jim Eussen	
Smith	Mike	Bridge Maintenance, Region 6	303-512-4267		Mentioned by Jane Hann as source for special use permit to obtain bridge access	
Terrones	Ray	Maintenance LTC Ops 1, Region 4	303-546-5642		Mentioned by Jim Eussen	
Welch	Anna	Region 1	303-365-7305		Mentioned by Debra Angulski	

Last Name	First Name	Affiliation	Phone	Email	Connection	Comment
Cooper	Gordon		303-920-1653		Information from response to generic email to online vendor Vestil	Source of information on curtain Strip Doors
Chacon	Jerry	Ultimate Bird Control, LLC	866-482-4737	<a href="mailto:info@birdslide.com">info@birdslide.com</a> <a href="mailto:jerry@birdslide.com">jerry@birdslide.com</a>	Manufactures Bird Slide product	Provided Bird Slide product tested in CBC #4
Seid	Joe	Bird-X.com			Response to question about use of Bird-X teflon sheets on building walls.	"No and I'm not sure that would work nor am I sure manu customers would apply that particular product on their structures??!! '[sic]"

## **1.2 Permanent Pigeon Roosting/Nesting Deterrents and Temporary Migratory Bird Nesting Deterrents**

Methods for deterring roosting and nesting can be subdivided on the basis of the way they function into the following types of categories: chemical (e.g., repellents, toxicants, fumigants), coatings (e.g., gels, slick surfaces), physical (e.g., spikes, wires, slides, curtains), removal (e.g., trapping, shooting, predator hunting of birds; removal of nests, eggs, food), and scaring (e.g., noise, static figures, moving figures). In addition to these methods, modification of structure through design can eliminate nesting and roosting sites. Tables 3 and 4, which are divided into sub-tables, list and evaluate methods/techniques that may permanently deter pigeon nesting/roosting (Tables 3a-3j) and temporarily deter swallow nesting (Tables 4a-4f).

A general summary of the effectiveness of the methods considered for deterring roosting and nesting is presented first, followed by specific comments pertinent to pigeons and swallows. In reviewing these general comments, keep in mind that the application of some of these methods to swallows is constrained because they are protected under the Migratory Bird Treaty Act. Pigeons, because they are introduced pest species, are not protected, except by basic humaneness and public opinion. Further, any method that might be applied to pigeons but could inadvertently affect protected species, must be constrained so as not to harm the protected species. The general effectiveness of the types of methods considered is as follows:

- The most effective of the deterrent methods evaluated are physical deterrents because they have the greatest longevity, require the least maintenance, and when properly installed and maintained will deter roosting and nesting.
- Some non-detrimental chemical methods that irritate birds sufficiently to cause them to avoid an area are next in effectiveness, and may be particularly effective in certain situations.
- Chemical toxicants and fumigants may be effective in the short term by reducing populations, but recruitment from other areas is anticipated to rapidly replenish the controlled population. Further, chemical toxicants are publicly unacceptable.
- Comments similar to those for chemical toxicants and fumigants apply to removal methods such as trapping, shooting, and removal of nests.
- Removal of eggs can effectively reduce bird populations if "dummy" eggs are substituted in nests, but this method is labor intensive, and difficult to implement unless the bird nests are concentrated in an easily accessible site.
- The presence of nesting predators is likely to result in some decline and scattering of prey bird populations within the predators hunting range, at least during the nesting season. While encouraging predator nesting is ecologically beneficial, it has its drawbacks since the presence near traffic of vulnerable young individuals of predator species, which may be uncommon, can result in their mortality.
- Removal of food sources can curtail bird populations (assuming food is the factor limiting their population) but is difficult to manage.

- Coatings such as gels may be effective for a short while until dust and debris render them ineffective. Further, they may stain their substrate and some of these products must be removed with a solvent, which presents contamination issues.
- Slick surfaces may be effective in two ways. First, application of a slick epoxy like coating to structures will retard their corrosion by droppings and also facilitate removal of the droppings. Such coatings might be applied to structures to facilitate their longevity, cleanup, and inspection, even if birds continue to be present. Second, application of a slick coating to a smooth removable liner might prevent nests from adhering on non-horizontal surfaces.
- Finally, the least effective of the deterrent methods evaluated are those that scare the birds. Birds have very strong site fidelity and readily acclimate to various types of disturbances. This is true of both stationary and mobile visual scare devices and of noise. In addition, noise that scares the birds is more likely to annoy the public than it is to deter birds from roosting or nesting even for a short time.

Multiple, effective solutions are needed because the sites where they are to be used differ extensively. Therefore, cost should not be a factor in determining the effectiveness of a method. Cost should, however, be considered when choosing one of the effective methods for use at a specific site.

All of the deterrent methods discussed require maintenance. Even the most effective of these methods must be installed correctly and modified to the site-specific situation to function properly. The approach to conducting field tests of the methods recommended here to temporarily deter swallow nesting is described below. Field testing of the methods recommended here to permanently deter pigeon roosting/nesting was outside the scope of this study.

**Tables 3a-3j. Evaluation of Permanent Pigeon Nesting/Dropping Deterrents.**

**Table 3a. Evaluation Criteria for Pigeon Dropping/Nesting Solutions-Chemical.**

<b>Product</b>	<b>Methyl Anthranilate</b>	<b>Alpha-chloralose</b>	<b>Avitrol</b>
Source	BirdTec, Inc. Nixalite, Inc.		
Effectiveness in Discouraging			
Roosting	<ul style="list-style-type: none"> <li>• Strong testimonials regarding success as a deterrent to roosting of birds in warehouses, equipment sheds, barns, etc. Species mentioned are starlings and sparrows. Likely to be most effective as a deterrent for roosting, since birds will be initially present for a sustained period. Likely most effective in protected locations where the aerosol will disperse less rapidly.</li> <li>• Works best on flying birds and in large open areas with large numbers of birds scattered randomly through the area.</li> </ul>	<ul style="list-style-type: none"> <li>• This chemical is used to sedate birds that have fed on bait containing alpha-chloralose and are to be killed by neck dislocation. In these latter birds, it serves as an anti-convulsant, since neck dislocation does not cause instantaneous unconsciousness. This chemical is often lethal at the doses ingested.</li> <li>• Thus it serves to remove birds that would otherwise use roosting sites.</li> </ul>	<ul style="list-style-type: none"> <li>• This is also a restricted-use pesticide. It is available in a whole-corn bait mixture.</li> <li>• Pigeons that eat the treated grain will behave erratically or gives warning cries, frightening the others in the flock.</li> <li>• Birds that eat the Avitrol usually die.</li> </ul>
Nesting	<ul style="list-style-type: none"> <li>• Unknown. May be more effective as a deterrent for roosting than nesting, as when birds are nest building, they</li> </ul>	<ul style="list-style-type: none"> <li>• See above comments on roosting.</li> </ul>	<ul style="list-style-type: none"> <li>• Comments on alpha-chloralose apply equally to Avitrol.</li> </ul>

Product	Methyl Anthranilate	Alpha-chloralose	Avitrol
	<p>move to an from the site repeatedly, and wouldn't get the full effect of the chemical until they were sitting on the nest, by which time the urge to stay would be at its peak.</p>		
Ease of Providing Needed Bridge Access	<ul style="list-style-type: none"> <li>Entire extent of exclusion site would need to be accessed to install tubing. Motor could be placed in an accessible location and connected to perforated tubing with nonperforated tubing where exclusion was not needed.</li> </ul>	<ul style="list-style-type: none"> <li>Alpha-chloralose can be mixed with the bait used to attract pigeons to traps. Baited traps can only be used in locations where other birds cannot ingest this bait and such traps must be closely monitored. Alpha-chloralose is a federally controlled, highly restricted-use drug and can only be used by authorized individuals. USDA-APHIS-Wildlife Services staff are authorized to use it to capture pigeons.</li> </ul>	<ul style="list-style-type: none"> <li>Comments on alpha-chloralose apply equally to Avitrol.</li> </ul>
Negative Impacts/Risks			
Humans	<ul style="list-style-type: none"> <li>None. Used in food stuffs with artificial grape flavors. Used as deterrent in fruit crop fields.</li> </ul>	<ul style="list-style-type: none"> <li>NA</li> </ul>	<ul style="list-style-type: none"> <li>Comments on alpha-chloralose apply equally to Avitrol.</li> </ul>
Birds	<ul style="list-style-type: none"> <li>Irritant, but apparently nontoxic; BirdTec looking for</li> </ul>	<ul style="list-style-type: none"> <li>At low doses causes stupefaction from which</li> </ul>	<ul style="list-style-type: none"> <li>Comments on alpha-chloralose apply equally to Avitrol.</li> </ul>

<b>Product</b>	<b>Methyl Anthranilate</b>	<b>Alpha-chloralose</b>	<b>Avitrol</b>
	old paper citing tests on birds	the birds recover. <ul style="list-style-type: none"> <li>• Lethal at high doses.</li> <li>• Lethal to both target and non-target species.</li> <li>• Can also result in mortality to raptors feeding in the area because if they ate a poisoned pigeon, they might also die.</li> </ul>	
Environment	<ul style="list-style-type: none"> <li>• None; naturally occurring substance that disperses.</li> </ul>	<ul style="list-style-type: none"> <li>• Also has negative effects on other bird species. It is used as a rodenticide, but its bitter taste and tendency to induce convulsions in mammals make it less useful for mammals.</li> </ul>	<ul style="list-style-type: none"> <li>• Comments on alpha-chloralose apply equally to Avitrol.</li> </ul>
Infrastructure	<ul style="list-style-type: none"> <li>• None</li> </ul>	<ul style="list-style-type: none"> <li>• None known</li> </ul>	<ul style="list-style-type: none"> <li>• Comments on alpha-chloralose apply equally to Avitrol.</li> </ul>
Cost			
Initial	<ul style="list-style-type: none"> <li>• Nixalite Bird Buffer (applies through a single applicator nozzle=max 1 acre protection)</li> <li>• fogforce liquid (.5 gal/month; 6 gal/yr)=\$780.00</li> <li>• hard poly cover=\$259.00</li> <li>• windicator haze=\$10.69</li> <li>• haze generator=\$8,685.00</li> <li>• Bird-Tec (applies through</li> </ul>	<ul style="list-style-type: none"> <li>• Available through the Pocatello Supply Depot, which is operated by the Division of Wildlife Services, Bureau of Sport Fisheries and Wildlife, a branch of the U. S. Fish and Wildlife Service--all a part of the Department of Interior.</li> </ul>	<ul style="list-style-type: none"> <li>• Available only to certified applicators through distributors listed at:  <a href="http://www.avitrol.com/Distributor/index.php">http://www.avitrol.com/Distributor/index.php</a> </li> </ul>

<b>Product</b>	<b>Methyl Anthranilate</b>	<b>Alpha-chloralose</b>	<b>Avitrol</b>
	perforated tubing); product cost not yet determined.	The major purpose of the Supply Depot is to provide rodent and predator control materials not available to the general public, to cooperating Federal, State and private agencies.	
Maintenance	<ul style="list-style-type: none"> <li>Monthly replenishment of liquid to be dispersed as a haze.</li> </ul>	<ul style="list-style-type: none"> <li>Is used in baited traps that must be monitored and the dosed grain must be removed at the end of each trapping session.</li> </ul>	<ul style="list-style-type: none"> <li>Comments on alpha-chloralose apply equally to Avitrol.</li> </ul>
Replacement	<ul style="list-style-type: none"> <li>Anecdotal evidence of 4 year operation. Relatively new product, without long term performance data.</li> </ul>	<ul style="list-style-type: none"> <li>Trapping is done in discrete events. This is not a system that is set up and left in place.</li> </ul>	<ul style="list-style-type: none"> <li>Comments on alpha-chloralose apply equally to Avitrol.</li> </ul>
Service Life	<ul style="list-style-type: none"> <li>Unknown</li> </ul>	<ul style="list-style-type: none"> <li>Traps can be reused repeatedly, once constructed. They may need occasional cleaning and repair</li> </ul>	<ul style="list-style-type: none"> <li>Comments on alpha-chloralose apply equally to Avitrol.</li> </ul>
Life-cycle	<ul style="list-style-type: none"> <li>4 plus years</li> </ul>	<ul style="list-style-type: none"> <li>Traps: at least 10 years if carefully stored and cared for.</li> <li>Dosed bait: must be collected and redistributed each time lethal trapping is initiated</li> </ul>	<ul style="list-style-type: none"> <li>Comments on alpha-chloralose apply equally to Avitrol.</li> </ul>



<b>Product</b>	<b>Methyl Anthranilate</b>	<b>Alpha-chloralose</b>	<b>Avitrol</b>
Effectiveness	<ul style="list-style-type: none"> <li>• Most effective in enclosed spaces. May also be effective in open areas since application is intermittent and can be varied using a timer.</li> <li>• Appears to be highly effective based on testimonials. This is a relatively new product without a long track record in diverse locations.</li> </ul>	<ul style="list-style-type: none"> <li>• Highly effective in the short term. Pigeons are killed (directly by alpha-chloralose or by neck dislocation). In long term, recruitment from adjacent pigeon populations is likely to replenish populations. Thus, trapping needs to be done repeatedly.</li> <li>• This functions to reduce pigeon populations, but will not completely eliminate them except very temporarily.</li> <li>• Not an appropriate method for swallows or other protected species.</li> </ul>	<ul style="list-style-type: none"> <li>• Comments on alpha-chloralose apply equally to Avitrol.</li> </ul>
<b>Installation</b>			
Method	<ul style="list-style-type: none"> <li>• Use existing power source. Solar or generator also possible. Heater is part of installations where temperature falls below 20o gel point. Successful in Norway and Chicago.</li> </ul>	<ul style="list-style-type: none"> <li>• Several trap designs are effective and can be purchased commercially or manufactured with welded wire and hog rings. Traps must be located at sites not frequented by other species. Traps are baited with un-dosed grain to develop the site as a</li> </ul>	<ul style="list-style-type: none"> <li>• Comments on alpha-chloralose apply equally to Avitrol.</li> </ul>

<b>Product</b>	<b>Methyl Anthranilate</b>	<b>Alpha-chloralose</b>	<b>Avitrol</b>
		feeding station. Dosed bait is then added, and captured birds are dispatched. Traps must be monitored so long as they contain dosed bait. This chemical can only be used by authorized personnel.	
Frequency	<ul style="list-style-type: none"> <li>Once installed system can be set for variable operation. Default is 30 sec. on, 1 min. purge, 5 min. off. Systems in place have operated for 4.5 years to date.</li> </ul>	<ul style="list-style-type: none"> <li>As needed. Will vary depending on percent mortality sustained by population.</li> </ul>	<ul style="list-style-type: none"> <li>Comments on alpha-chloralose apply equally to Avitrol.</li> </ul>
Ease	<ul style="list-style-type: none"> <li>Tubing must be placed everywhere the chemical is to be released. Need for power source may be a deterrent.</li> </ul>	<ul style="list-style-type: none"> <li>Easy to use, but constrained by legal requirements restricting use of chemical.</li> <li>Trapping is labor intensive.</li> </ul>	<ul style="list-style-type: none"> <li>Comments on alpha-chloralose apply equally to Avitrol.</li> </ul>
Maintenance			
Requirements	<ul style="list-style-type: none"> <li>Refill of chemical every 45-60 days. Likely need to replace tubing after several years</li> </ul>	<ul style="list-style-type: none"> <li>No real maintenance since this is a repeated rather than installed/maintained type of control.</li> </ul>	<ul style="list-style-type: none"> <li>Comments on alpha-chloralose apply equally to Avitrol.</li> </ul>
Cost	<ul style="list-style-type: none"> <li>Fogforce liquid (.5 gal/month; 6 gal/yr)=\$780.00</li> <li>Cost from Bird-Tec expected</li> </ul>	<ul style="list-style-type: none"> <li>NA</li> </ul>	<ul style="list-style-type: none"> <li>Comments on alpha-chloralose apply equally to Avitrol.</li> </ul>

<b>Product</b>	<b>Methyl Anthranilate</b>	<b>Alpha-chloralose</b>	<b>Avitrol</b>
	to be similar.		
Ease	<ul style="list-style-type: none"> <li>• Readily refilled on monthly basis.</li> </ul>	<ul style="list-style-type: none"> <li>• NA</li> </ul>	<ul style="list-style-type: none"> <li>• Comments on alpha-chloralose apply equally to Avitrol.</li> </ul>
Availability	<ul style="list-style-type: none"> <li>• Readily available from two suppliers who have differing application methods.</li> </ul>	<ul style="list-style-type: none"> <li>• Restricted availability.</li> </ul>	<ul style="list-style-type: none"> <li>• Comments on alpha-chloralose apply equally to Avitrol.</li> </ul>
Technology			
Public Acceptance	<ul style="list-style-type: none"> <li>• Good—presence of a grape odor</li> </ul>	<ul style="list-style-type: none"> <li>• Poor, particularly if baited traps, dead/dying birds are within public view</li> </ul>	<ul style="list-style-type: none"> <li>• Comments on alpha-chloralose apply equally to Avitrol.</li> </ul>
Acceptability	<ul style="list-style-type: none"> <li>• Good—odor is used</li> </ul>	<ul style="list-style-type: none"> <li>• Poor because birds are not just moved to more acceptable sites, but are killed.</li> </ul>	<ul style="list-style-type: none"> <li>• Comments on alpha-chloralose apply equally to Avitrol.</li> </ul>
Constructability	<ul style="list-style-type: none"> <li>• Because chemical is aerosolized from tubing, long runs of tubing are needed to cover the exclusion area. Motor will support up to 800 feet of tubing.</li> </ul>	<ul style="list-style-type: none"> <li>• Traps can be constructed readily.</li> <li>• Traps can also be purchased.</li> </ul>	<ul style="list-style-type: none"> <li>• Comments on alpha-chloralose apply equally to Avitrol.</li> </ul>
Compliance with Regulations	<ul style="list-style-type: none"> <li>• This chemical is not a controlled substance.</li> </ul>	<ul style="list-style-type: none"> <li>• Chemical can only be used by authorized personnel.</li> </ul>	<ul style="list-style-type: none"> <li>• Comments on alpha-chloralose apply equally to Avitrol.</li> </ul>
Compliance with Environmental Requirements	<ul style="list-style-type: none"> <li>• EPA has exempted from need to develop a tolerance level. Are no environmental restrictions</li> </ul>	<ul style="list-style-type: none"> <li>• In addition to control of the chemical, they way in which it is to be used is stipulated.</li> </ul>	<ul style="list-style-type: none"> <li>• Comments on alpha-chloralose apply equally to Avitrol.</li> </ul>
Other?	<ul style="list-style-type: none"> <li>• None</li> </ul>	<ul style="list-style-type: none"> <li>• None</li> </ul>	<ul style="list-style-type: none"> <li>• Comments on alpha-chloralose</li> </ul>

<b>Product</b>	<b>Methyl Anthranilate</b>	<b>Alpha-chloralose</b>	<b>Avitrol</b>
			apply equally to Avitrol.
Summary			
Advantages	<ul style="list-style-type: none"> <li>• Application can be to very specific area, nontoxic, nonstructural, application readily started/stopped.</li> </ul>	<ul style="list-style-type: none"> <li>• Causes rapid (if transitory) reduction in pigeon population</li> </ul>	<ul style="list-style-type: none"> <li>• Comments on alpha-chloralose apply equally to Avitrol.</li> </ul>
Disadvantages	<ul style="list-style-type: none"> <li>• Need for power; may not be effective as a nesting deterrent</li> </ul>	<ul style="list-style-type: none"> <li>• Must be used by authorized personnel</li> <li>• Is labor intensive</li> <li>• Causes mortality</li> <li>• Reduces but does not eliminate pigeon roosting and nesting</li> <li>• Must be done repeatedly to keep populations in check</li> <li>• Presents poor public image</li> <li>• Can only be used on species that are not protected</li> </ul>	<ul style="list-style-type: none"> <li>• Comments on alpha-chloralose apply equally to Avitrol.</li> </ul>

**Table 3b. Evaluation Criteria for Pigeon Dropping/Nesting Solutions-Coatings.**

<b>Product</b>	<b>Tanglefoot</b>	<b>Bird B Gone Gel</b>	<b>AeroKret and Other Permanent Coatings</b>
Source	<ul style="list-style-type: none"> <li>Nixalite</li> </ul>	<ul style="list-style-type: none"> <li>Bird B Gone Inc.</li> </ul>	<ul style="list-style-type: none"> <li>Analytical Services &amp; Materials, Inc.</li> </ul>
Effectiveness in Discouraging			
Roosting	<ul style="list-style-type: none"> <li>Discourages birds from landing on all types of surfaces</li> <li>Registered with EPA for use against pigeons</li> </ul>	<ul style="list-style-type: none"> <li>Comments on Tanglefoot apply equally to Bird B Gone gel.</li> </ul>	<ul style="list-style-type: none"> <li>Because AeroKret provides a very slick surface, it might discourage roosting on sites that are already almost too steep.</li> <li>The primary usefulness of this product is in facilitating the cleanup of droppings because it is hydrophobic and has a very low surface energy and water contact angle so that droppings will readily wash off</li> <li>Further, AeroKret will minimize corrosion and other negative impacts to structures from droppings because it consists of a thin epoxy based primer followed by a topcoat.</li> <li>AeroKret is resistant to salt, sydraulic fluid, chemicals, biomass, and ice, as well as durable in extreme weather, to UV and ozone, and extreme temperatures</li> </ul>
Nesting	<ul style="list-style-type: none"> <li>Unlikely to deter nesting, as nesting materials can be dropped onto the sticky surface</li> </ul>	<ul style="list-style-type: none"> <li>Comments on Tanglefoot apply equally to Bird B Gone gel.</li> </ul>	<ul style="list-style-type: none"> <li>See comments above for roosting.</li> </ul>

<b>Product</b>	<b>Tanglefoot</b>	<b>Bird B Gone Gel</b>	<b>AeroKret and Other Permanent Coatings</b>
	until it is totally ineffective		
Ease of Providing Needed Bridge Access	<ul style="list-style-type: none"> <li>• Must be applied with cartridge gun in thin beads along the length of the surface to be protected</li> </ul>	<ul style="list-style-type: none"> <li>• Comments on Tanglefoot apply equally to Bird B Gone gel.</li> </ul>	<ul style="list-style-type: none"> <li>• Both primer and topcoat may be sprayed on a surface that has been washed, degreased, and then sand blasted or scuffed with an abrasive disc</li> <li>• Most practical application would be to new bridge or other structure components</li> <li>• On existing structures, surface preparation in the field may be a problem, but ability to spray primer and topcoat facilitates product application.</li> </ul>
Negative Impacts/Risks			
Humans	<ul style="list-style-type: none"> <li>• None known, except secondary risks from initial cleanup of site, and periodic removal of product with solvent.</li> </ul>	<ul style="list-style-type: none"> <li>• Comments on Tanglefoot apply equally to Bird B Gone gel.</li> </ul>	<ul style="list-style-type: none"> <li>• Products used in surface preparation may require PPE</li> <li>• Respiratory protection required during product application</li> <li>• None once product has cured</li> </ul>
Birds	<ul style="list-style-type: none"> <li>• If too much is applied pigeons and non-target species may become mired in it, resulting in their mortality</li> </ul>	<ul style="list-style-type: none"> <li>• Comments on Tanglefoot apply equally to Bird B Gone gel.</li> </ul>	<ul style="list-style-type: none"> <li>• None once product has cured</li> </ul>
Environment	<ul style="list-style-type: none"> <li>• Impacts from associated use of cleaning products and solvents (assuming proper removal and disposal of spent Tanglefoot product).</li> </ul>	<ul style="list-style-type: none"> <li>• Comments on Tanglefoot apply equally to Bird B Gone gel.</li> </ul>	<ul style="list-style-type: none"> <li>• None once product has cured. Final product is inert and non-toxic.</li> <li>• If product were to be applied in the field, surface preparation products could adversely affect the</li> </ul>

<b>Product</b>	<b>Tanglefoot</b>	<b>Bird B Gone Gel</b>	<b>AeroKret and Other Permanent Coatings</b>
			environment (e.g., material on surfaces could wash into surface waters and degreasers are likely to be environmentally controlled substances).
Infrastructure	<ul style="list-style-type: none"> <li>• None known.</li> </ul>	<ul style="list-style-type: none"> <li>• Comments on Tanglefoot apply equally to Bird B Gone gel.</li> </ul>	<ul style="list-style-type: none"> <li>• Once product is applied infrastructure will benefit</li> </ul>
Cost			
Initial	<ul style="list-style-type: none"> <li>• 1 oz/foot=100 oz/100 ft x 2 beads=200 oz=19 tubes</li> <li>• 24 10.2 oz cartridges=\$215.52</li> </ul>	<ul style="list-style-type: none"> <li>• Similar to Tanglefoot.</li> </ul>	<ul style="list-style-type: none"> <li>• Dependant on volume purchased.</li> </ul>
Maintenance	<ul style="list-style-type: none"> <li>• Lasts 2 month to 2 years depending on environment (dust, pollution, bugs and debris, etc.)</li> <li>• When it loses its tackiness, it must be removed and reapplied</li> </ul>	<ul style="list-style-type: none"> <li>• Comments on Tanglefoot apply equally to Bird B Gone gel.</li> </ul>	<ul style="list-style-type: none"> <li>• Expected to be long term solution.</li> <li>• For example, after 1 year in seawater the coating on a boat hull remained adherent, smooth, and free of barnacles.</li> </ul>
Replacement	<ul style="list-style-type: none"> <li>• Can be removed from tools with vegetable oil, but site must be scraped and cleaned with mineral spirits</li> </ul>	<ul style="list-style-type: none"> <li>• Comments on Tanglefoot apply equally to Bird B Gone gel.</li> </ul>	<ul style="list-style-type: none"> <li>• None anticipated.</li> </ul>
Service Life	<ul style="list-style-type: none"> <li>• 2 month to 2 years depending on environment</li> </ul>	<ul style="list-style-type: none"> <li>• Comments on Tanglefoot apply equally to Bird B Gone gel.</li> </ul>	<ul style="list-style-type: none"> <li>• Unknown.</li> </ul>
Life-cycle	<ul style="list-style-type: none"> <li>• Depends on local environment</li> </ul>	<ul style="list-style-type: none"> <li>• Comments on Tanglefoot apply equally to Bird B Gone gel.</li> </ul>	<ul style="list-style-type: none"> <li>• Unknown.</li> </ul>

<b>Product</b>	<b>Tanglefoot</b>	<b>Bird B Gone Gel</b>	<b>AeroKret and Other Permanent Coatings</b>
Effectiveness	<ul style="list-style-type: none"> <li>• May be temporarily effective until stickiness is lost.</li> <li>• Dust and pollution anticipated in urban environment are likely to result in a short life cycle.</li> </ul>	<ul style="list-style-type: none"> <li>• Comments on Tanglefoot apply equally to Bird B Gone gel.</li> </ul>	<ul style="list-style-type: none"> <li>• May not be cost effective simply as a deterrent to roosting or nesting on sloped surfaces or as an aid to cleanup of droppings</li> <li>• May be cost effective when ability to deter corrosion and damage to structure from acid in droppings is considered.</li> <li>• Field testing under local conditions would be needed to determine how much money is saved in reduced maintenance and repair of coated structural components.</li> </ul>
Installation			
Method	<ul style="list-style-type: none"> <li>• Apply 1/4" bead for pigeons</li> <li>• One bead 1" from outside, with additional beads 2" apart for surfaces 3" and wider</li> <li>• 1" gap every 12" for surface drainage</li> </ul>	<ul style="list-style-type: none"> <li>• Comments on Tanglefoot apply equally to Bird B Gone gel.</li> </ul>	<ul style="list-style-type: none"> <li>• Clean surface as noted above.</li> <li>• Spray both primer and topcoat.</li> </ul>
Frequency	<ul style="list-style-type: none"> <li>• When tackiness is lost must be reapplied</li> <li>• Precise frequency depends on local environment</li> </ul>	<ul style="list-style-type: none"> <li>• Comments on Tanglefoot apply equally to Bird B Gone gel.</li> </ul>	<ul style="list-style-type: none"> <li>• Single application anticipated.</li> </ul>
Ease	<ul style="list-style-type: none"> <li>• Not difficult to apply but labor intensive</li> </ul>	<ul style="list-style-type: none"> <li>• Comments on Tanglefoot apply equally to Bird B Gone gel.</li> </ul>	<ul style="list-style-type: none"> <li>• Readily applied once surface has been prepared.</li> </ul>
Maintenance			
Requirements	<ul style="list-style-type: none"> <li>• Surfaces must be clean and dry</li> </ul>	<ul style="list-style-type: none"> <li>• Comments on Tanglefoot</li> </ul>	<ul style="list-style-type: none"> <li>• None anticipated.</li> </ul>



<b>Product</b>	<b>Tanglefoot</b>	<b>Bird B Gone Gel</b>	<b>AeroKret and Other Permanent Coatings</b>
	and sealed if porous; effective from 40 to 100 oF.	apply equally to Bird B Gone gel.	<ul style="list-style-type: none"> <li>• Need for maintenance in local setting unknown.</li> </ul>
Cost	<ul style="list-style-type: none"> <li>• NA</li> </ul>	<ul style="list-style-type: none"> <li>• NA</li> </ul>	<ul style="list-style-type: none"> <li>• See above.</li> </ul>
Ease	<ul style="list-style-type: none"> <li>• Can be applied on waterproof tape if removal is anticipated</li> </ul>	<ul style="list-style-type: none"> <li>• Comments on Tanglefoot apply equally to Bird B Gone gel.</li> </ul>	<ul style="list-style-type: none"> <li>• See above.</li> </ul>
Availability	<ul style="list-style-type: none"> <li>• Readily available</li> </ul>	<ul style="list-style-type: none"> <li>• Comments on Tanglefoot apply equally to Bird B Gone gel.</li> </ul>	<ul style="list-style-type: none"> <li>• Readily available from Analytical Services &amp; Materials, Inc.</li> </ul>
Technology			
Public Acceptance	<ul style="list-style-type: none"> <li>• May be unsightly</li> <li>• Concept acceptable so long as correctly applied.</li> </ul>	<ul style="list-style-type: none"> <li>• Comments on Tanglefoot apply equally to Bird B Gone gel.</li> </ul>	<ul style="list-style-type: none"> <li>• Excellent.</li> </ul>
Acceptability	<ul style="list-style-type: none"> <li>• Unacceptable if incorrectly applied and birds become stuck</li> <li>• This is particularly true if non-target species are affected.</li> </ul>	<ul style="list-style-type: none"> <li>• Comments on Tanglefoot apply equally to Bird B Gone gel.</li> </ul>	<ul style="list-style-type: none"> <li>• Excellent</li> </ul>
Constructability	<ul style="list-style-type: none"> <li>• Easy to apply, but requires ready access to entire surface to be protected.</li> </ul>	<ul style="list-style-type: none"> <li>• Comments on Tanglefoot apply equally to Bird B Gone gel.</li> </ul>	<ul style="list-style-type: none"> <li>• Most feasible as a coating on components for new structure.</li> </ul>
Compliance with Regulations	<ul style="list-style-type: none"> <li>• Active ingredient is Polybutene</li> <li>• Non drying, non-toxic</li> <li>• Registered with EPA for use against pigeons, starlings, and [house] sparrows</li> </ul>	<ul style="list-style-type: none"> <li>• Ingredients are: Polybutene 93%; Inert 7%</li> <li>• Comments on Tanglefoot apply equally to Bird B Gone gel.</li> </ul>	<ul style="list-style-type: none"> <li>• Inert and non-toxic once cured.</li> </ul>
Compliance with Environmental Requirements	<ul style="list-style-type: none"> <li>• Complies.</li> </ul>	<ul style="list-style-type: none"> <li>• Comments on Tanglefoot apply equally to Bird B</li> </ul>	<ul style="list-style-type: none"> <li>• Inert and non-toxic once cured.</li> </ul>

<b>Product</b>	<b>Tanglefoot</b>	<b>Bird B Gone Gel</b>	<b>AeroKret and Other Permanent Coatings</b>
		Gone gel.	
Other?	<ul style="list-style-type: none"> <li>• NA</li> </ul>	<ul style="list-style-type: none"> <li>• NA</li> </ul>	<ul style="list-style-type: none"> <li>• NA</li> </ul>
Summary			
Advantages	<ul style="list-style-type: none"> <li>• Simple solution</li> <li>• Minimal equipment costs.</li> <li>• May be moderately effective for a short period of time.</li> </ul>	<ul style="list-style-type: none"> <li>• Comments on Tanglefoot apply equally to Bird B Gone gel.</li> </ul>	<ul style="list-style-type: none"> <li>• Minimized detrimental effects of droppings on structural integrity</li> <li>• May make marginally useable sloped surfaces unuseable by pigeons</li> <li>• Facilitated cleanup of droppings</li> </ul>
Disadvantages	<ul style="list-style-type: none"> <li>• Not specific to target species</li> <li>• Must be reapplied often, especially in urban environments</li> <li>• Unsightly</li> <li>• Reliably active for only a relatively short time</li> <li>• Not effective in deterring nesting</li> <li>• Must be removed with solvents.</li> </ul>	<ul style="list-style-type: none"> <li>• Comments on Tanglefoot apply equally to Bird B Gone gel.</li> </ul>	<ul style="list-style-type: none"> <li>• Difficult to adequately prepare existing surfaces for application of product.</li> <li>• Not a direct deterrent to most pigeon roosting and nesting activity</li> </ul>

**Table 3c. Evaluation Criteria for Pigeon Dropping/Nesting Solutions - Other.**

<b>Product</b>	<b>APHIS-WR</b>	<b>Bridge Redesign</b>
Source and Discussion	<ul style="list-style-type: none"> <li>• The US Department of Agriculture, Animal and Plant Health Inspection Service (APHIS), Wildlife Services group in Colorado can be contacted as follows:               <ul style="list-style-type: none"> <li>• Colorado Wildlife Services State Director, 12345 West Alameda Parkway, Suite 204, Lakewood, CO 80228</li> <li>• 303 236 5810 (phone), 303 236 5821 (fax)</li> <li>• <a href="http://www.aphis.usda.gov/wildlife_damage/colorado_info.shtml">http://www.aphis.usda.gov/wildlife_damage/colorado_info.shtml</a></li> </ul> </li> <li>• Establishment of a cooperative agreement between a DOT and APHIS has been done successfully in Oregon and likely other states. APHIS manages swallows at Oregon bridges as needed and similar services should be available for pigeons in Colorado. In the Oregon situation, APHIS charges ODOT for actual time and materials expended by its personnel; no profit is paid because APHIS is a government agency.</li> <li>• CDOT could establish a similar cooperative agreement with APHIS-WS in Colorado.</li> <li>• Ultimately, using the services of APHIS-WS may be more cost effective than the hiring of subcontractors to install deterrents, since the subcontractors hope to make a profit. The success of this approach would depend on the timely availability of APHIS-WS personnel and the cost of their salaries relative to those</li> </ul>	<ul style="list-style-type: none"> <li>• Overall, bridge redesign is considered the best long term solution for eliminating or greatly reducing pigeon roosting and nesting.</li> <li>• The effectiveness of this solution, however, is constrained to bridges that are new or substantially replaced.</li> <li>• Bridge redesign is discussed in the text of the Interim Report under Tasks V and VI.</li> <li>• Generally speaking, there are several approaches that are expected to be highly successful on new construction:</li> <li>• Enclosing the structural components of a bridge so that no horizontal surfaces having top surfaces useable by pigeons are accessible</li> <li>• Where box girders are used, screen off box girder ends, access doors, and all other openings</li> <li>• Modifying the shape of cement girders so that they lack horizontal surfaces useable by pigeons</li> <li>• Modifying or supplementing the shape of steel beams and girders so that they lack horizontal surfaces useable by pigeons.</li> <li>• The tabular topics below are not relevant to an effective consideration of bridge redesign. Please see the Interim Report discussion of Tasks V and VI.</li> </ul>

Product	APHIS-WR	Bridge Redesign
	<p>of subcontractors.</p> <ul style="list-style-type: none"> <li>• Selection and installation/maintenance of roosting/nesting deterrent devices by CDOT personnel would likely be the most cost effective solution in the long run. The success of this approach would depend on:</li> <li>• Developing and following a specified protocol for installing, monitoring, and maintaining pigeon deterrent devices</li> <li>• Establishing a proactive rather than reactive group within the maintenance division that is responsible for regular installation, monitoring, and maintenance of pigeon deterrent devices.</li> <li>• The tabular topics below are not relevant to an effective consideration of a cooperative agreement between CDOT and APHIS-WS in Colorado.</li> </ul>	

**Table 3d. Evaluation Criteria for Pigeon Dropping/Nesting Solutions – Spikes/Wires.**

<b>Product</b>	<b>Spikes</b>	<b>Wires</b>
Source	<ul style="list-style-type: none"> <li>• Nixalite, Inc., and others</li> </ul>	<ul style="list-style-type: none"> <li>• Nixalite, Inc., and others</li> </ul>
Effectiveness in Discouraging		
Roosting	<ul style="list-style-type: none"> <li>• Work better than other methods when a lot of birds are present or when small birds are present</li> <li>• Very effective when properly applied and maintained.</li> <li>• Adherence to prescribed spacing and use of multiple rows of spikes where needed is critical to success.</li> <li>• Debris must be cleaned from spikes as needed, especially during most active nesting season.</li> </ul>	<ul style="list-style-type: none"> <li>• Works best for large birds on surfaces where problem birds are few in number</li> <li>• Adherence to prescribed spacing and use of multiple rows of wires where needed is critical to success.</li> <li>• Debris must be cleaned from wires as needed, especially during most active nesting season.</li> </ul>
Nesting	<ul style="list-style-type: none"> <li>• Will preclude nesting, although, nesting material dropped onto spikes will in time cover them at which point the spikes provide good stability for a nest.</li> <li>• Very effective when properly applied and maintained.</li> </ul>	<ul style="list-style-type: none"> <li>• See comment regarding spikes. Wires may be more readily buried by nesting material than spikes.</li> </ul>
Ease of Providing Needed Bridge Access	<ul style="list-style-type: none"> <li>• Strips of spikes must be screwed into surface, requiring access to almost the entire length of surface to be protected.</li> </ul>	<ul style="list-style-type: none"> <li>• Wires can be set up with 10' between anchor posts so long as there is a guide post half way between them.</li> <li>• This means that access is needed every 5' along the surface to be protected.</li> </ul>
Negative Impacts/Risks		
Humans	<ul style="list-style-type: none"> <li>• None</li> </ul>	<ul style="list-style-type: none"> <li>• None</li> </ul>
Birds	<ul style="list-style-type: none"> <li>• None, except that other species may also be deterred from perching or nesting at the</li> </ul>	<ul style="list-style-type: none"> <li>• See comment for spikes.</li> </ul>

<b>Product</b>	<b>Spikes</b>	<b>Wires</b>
	protected locations	
Environment	<ul style="list-style-type: none"> <li>• None</li> </ul>	<ul style="list-style-type: none"> <li>• None</li> </ul>
Infrastructure	<ul style="list-style-type: none"> <li>• None</li> </ul>	<ul style="list-style-type: none"> <li>• None</li> </ul>
Cost		
Initial	<ul style="list-style-type: none"> <li>• 4 inch spikes to protect 4 inch single exposed surface</li> <li>• Available in 2 ft and 4 ft lengths</li> <li>• 100 ft kit=\$518.00</li> <li>• Wider surfaces require more rows of spikes.</li> </ul>	<ul style="list-style-type: none"> <li>• 2 rows cable to protect 4 inch by 100 foot single exposed surface</li> <li>• cable=\$24.95</li> <li>• crimp tool=\$22.98</li> <li>• ferrules-\$5.00</li> <li>• springs=\$15.00</li> <li>• posts-\$187.50</li> <li>• screws-\$36.00</li> </ul>
Maintenance	<ul style="list-style-type: none"> <li>• Minimal cost if done consistently.</li> </ul>	<ul style="list-style-type: none"> <li>• Minimal cost if done consistently.</li> </ul>
Replacement	<ul style="list-style-type: none"> <li>• Spikes are made of stainless steel and if properly installed and maintained should last for many years without replacement.</li> </ul>	<ul style="list-style-type: none"> <li>• Wires are made of stainless steel and if properly installed and maintained should last for many years without replacement.</li> </ul>
Service Life	<ul style="list-style-type: none"> <li>• Unknown</li> </ul>	<ul style="list-style-type: none"> <li>• Unknown</li> </ul>
Life-cycle	<ul style="list-style-type: none"> <li>• Unknown</li> </ul>	<ul style="list-style-type: none"> <li>• Unknown</li> </ul>
Effectiveness	<ul style="list-style-type: none"> <li>• Highly effective if properly installed and maintained.</li> </ul>	<ul style="list-style-type: none"> <li>• Moderately effective if properly installed and maintained.</li> </ul>
Installation		
Method	<ul style="list-style-type: none"> <li>• Screwed into surface to be protected at strictly specified distances.</li> <li>• Minimum of 1/4" wire overhang and 1/2" base strip overhang are required.</li> <li>• Multiple rows of Model S strips or of combined Model S and H strips must be used to adequately cover surfaces wider that 3.5 " if</li> </ul>	<ul style="list-style-type: none"> <li>• Screwed into surface to be protected at strictly specified distances.</li> <li>• 1" maximum space between a wire row and any outside [or inside] edge or wall</li> <li>• 3" maximum space between rows of wire.</li> <li>• Excellent installation instructions are available at:</li> </ul>

<b>Product</b>	<b>Spikes</b>	<b>Wires</b>
	double exposed or wider than 4" if single exposed. <ul style="list-style-type: none"> <li>• Excellent installation instructions are available at:  <a href="http://www.nixalite.com/PDFs/installingmodel snixalite.pdf">http://www.nixalite.com/PDFs/installingmodel snixalite.pdf</a> </li> </ul>	<a href="http://www.nixalite.com/PDFs/flitelinepost wire4pg.pdf">http://www.nixalite.com/PDFs/flitelinepost wire4pg.pdf</a>
Frequency	<ul style="list-style-type: none"> <li>• Infrequent, as product has longevity (if stainless steel rather than plastic spikes are used)</li> </ul>	<ul style="list-style-type: none"> <li>• Infrequent.</li> </ul>
Ease	<ul style="list-style-type: none"> <li>• Easy but labor intensive and access to length of surface to be protected is required.</li> </ul>	<ul style="list-style-type: none"> <li>• Easy but labor intensive and access to much of the length of surface to be protected is required.</li> </ul>
Maintenance		
Requirements	<ul style="list-style-type: none"> <li>• If spikes are installed properly and maintenance is done timely, debris on spikes should be removable with a jet of compressed air, avoiding the need for a high pressure water jet and its associated discharge issues or any need for hand cleaning of spikes.</li> </ul>	<ul style="list-style-type: none"> <li>• See comment for spikes.</li> </ul>
Cost	<ul style="list-style-type: none"> <li>• Low</li> </ul>	<ul style="list-style-type: none"> <li>• Low</li> </ul>
Ease	<ul style="list-style-type: none"> <li>• Easily done if included in a proactive, regular program</li> </ul>	<ul style="list-style-type: none"> <li>• See comment for spikes.</li> </ul>
Availability	<ul style="list-style-type: none"> <li>• Readily available.</li> </ul>	<ul style="list-style-type: none"> <li>• Readily available</li> </ul>
Technology		
Public Acceptance	<ul style="list-style-type: none"> <li>• High</li> </ul>	<ul style="list-style-type: none"> <li>• High</li> </ul>
Acceptability	<ul style="list-style-type: none"> <li>• High</li> </ul>	<ul style="list-style-type: none"> <li>• High</li> </ul>
Constructability	<ul style="list-style-type: none"> <li>• High</li> </ul>	<ul style="list-style-type: none"> <li>• High</li> </ul>
Compliance with Regulations	<ul style="list-style-type: none"> <li>• High</li> </ul>	<ul style="list-style-type: none"> <li>• High</li> </ul>

<b>Product</b>	<b>Spikes</b>	<b>Wires</b>
Compliance with Environmental Requirements	<ul style="list-style-type: none"> <li>• High</li> </ul>	<ul style="list-style-type: none"> <li>• High</li> </ul>
Other?	<ul style="list-style-type: none"> <li>• NA</li> </ul>	<ul style="list-style-type: none"> <li>• NA</li> </ul>
Summary		
Advantages	<ul style="list-style-type: none"> <li>• Highly effective.</li> <li>• High longevity.</li> <li>• Excellent public acceptance and compliance.</li> </ul>	<ul style="list-style-type: none"> <li>• Are less expensive and a bit easier to install than spikes, so they should be used in areas where pigeon density is low.</li> </ul>
Disadvantages	<ul style="list-style-type: none"> <li>• Must be installed carefully according to specifications.</li> <li>• Must be checked and kept clear of debris on a regular basis.</li> <li>• Because they are expensive and labor intensive to install, spikes should be used in particular problem areas.</li> </ul>	<ul style="list-style-type: none"> <li>• See comments for spikes.</li> <li>• Wires are less effective than spikes.</li> </ul>



**Table 3e. Evaluation Criteria for Pigeon Dropping/Nesting Solutions – Corner Slope/Netting.**

<b>Product</b>	<b>Corner Slope</b>	<b>Netting</b>
Source	<ul style="list-style-type: none"> <li>• Ultimate Bird Control LLC. (866-482-4737) for Bird Slide, a plastic corner slope.</li> <li>• A home made version of a corner slope made with a flexible piece of fiberglass or plastic can also be used. Dipcraft Manufacturing Company (<a href="http://www.dipcraft.com/pricing.html">http://www.dipcraft.com/pricing.html</a>) carries fiberglass panels.</li> </ul>	<ul style="list-style-type: none"> <li>• Nixalite, Inc. (<a href="http://www.nixalite.com/default.aspx?clid=CPzK057Q1ZACFRuhFQodBTLrXA">http://www.nixalite.com/default.aspx?clid=CPzK057Q1ZACFRuhFQodBTLrXA</a>) and others</li> </ul>
Effectiveness in Discouraging		
Roosting	<ul style="list-style-type: none"> <li>• Highly effective in deterring pigeon roosting.</li> </ul>	<ul style="list-style-type: none"> <li>• Netting is highly effective in discouraging pigeon roosting if it is carefully installed so that there are no openings for the birds to slip through and the netting is taut to prevent the birds from becoming tangled in it.</li> <li>• Because pigeons can roost in so many locations, the netting must cover all horizontal surfaces to be effective.</li> </ul>
Nesting	<ul style="list-style-type: none"> <li>• Highly effective in deterring pigeon nesting.</li> </ul>	<ul style="list-style-type: none"> <li>• Similarly, netting is highly effective in discouraging pigeon nesting if it is carefully installed.</li> </ul>
Ease of Providing Needed Bridge Access	<ul style="list-style-type: none"> <li>• Bird Slide is installed on a clean surface with silicone adhesive. Therefore access to the CBC or bridge must be sufficient to clean the surface and place 4' lengths of the Bird Slide Material. If there are protrusions from the horizontal surface to be protected, careful measurements must be taken so the Bird Slide</li> </ul>	<ul style="list-style-type: none"> <li>• Installation of netting is very labor intensive.</li> <li>• Installing netting beneath high bridges can be difficult.</li> </ul>

Product	Corner Slope	Netting
	<p>can be cut to fit around the protrusions.</p> <ul style="list-style-type: none"> <li>Fiberglass panels could be installed in permanently attached angle iron. CBC and bridge ceilings, walls, and abutments would need to be accessed for the initial installation of the angle iron.</li> </ul>	
Negative Impacts/Risks		
Humans	<ul style="list-style-type: none"> <li>None</li> </ul>	<ul style="list-style-type: none"> <li>None, although netting can be less than aesthetic if it is visible to the public.</li> </ul>
Birds	<ul style="list-style-type: none"> <li>None</li> </ul>	<ul style="list-style-type: none"> <li>None, if the netting is properly installed and maintained.</li> <li>Netting that is loose or has dangling threads, etc. can entrap birds and result in mortality.</li> </ul>
Environment	<ul style="list-style-type: none"> <li>None</li> </ul>	<ul style="list-style-type: none"> <li>None.</li> </ul>
Infrastructure	<ul style="list-style-type: none"> <li>None</li> </ul>	<ul style="list-style-type: none"> <li>None.</li> </ul>
Cost		
Initial	<ul style="list-style-type: none"> <li>Costs and available dealers can be found by calling 1-866-482-4737</li> <li>Dipcraft Manufacturing Company will provide quotes for specific orders: <ul style="list-style-type: none"> <li>111 West Braddock Avenue</li> <li>Braddock, PA 15104</li> <li>412-351-2363</li> <li>800-245-6145</li> <li>Fax: 412-351-4528</li> </ul> </li> </ul>	<ul style="list-style-type: none"> <li>50x100 ft KH net=\$1,750.00</li> <li>250 ft cable=\$40.95</li> <li>turnbuckles (10)=\$178.70</li> <li>misc. hardware (thimbles, clamps, d rings, screw eyes, eyebolts, etc.)=\$500.00</li> <li>Pneumatic ring tool=\$497.35</li> </ul>
Maintenance	<ul style="list-style-type: none"> <li>Minimal maintenance cost. Bird Slide can be painted, so the cost of periodic painting could be figured in, although the painting is</li> </ul>	<ul style="list-style-type: none"> <li>Minimal since this would not be a permanent installation.</li> </ul>

Product	Corner Slope	Netting
	<p>primarily for aesthetic reasons. For a permanent installation, such as desired for pigeons, painting might be desirable in some settings.</p> <ul style="list-style-type: none"> <li>• Maintenance unlikely to be needed for temporary installation.</li> </ul>	
Replacement	<ul style="list-style-type: none"> <li>• Same an initial investment.</li> </ul>	<ul style="list-style-type: none"> <li>• Even though pigeons are not a protected species, netting must be kept in good repair without holes or dangling threads. This is because pigeons use highly public places, and the sight of dangling dead birds would create poor public image, as well as evidence unethical treatment of animals.</li> <li>• Replacement costs would be the same as initial purchase costs since net repair would be labor intensive and too costly.</li> </ul>
Service Life	<ul style="list-style-type: none"> <li>• No repair likely except for silicone fill of minor gouges.</li> </ul>	<ul style="list-style-type: none"> <li>• Materials used are expendable. Would need to be replaced if damaged.</li> </ul>
Life-cycle	<ul style="list-style-type: none"> <li>• Bird-Slide touted to provide "years of "bird-free" protection."</li> <li>• Fiberglass panels should be readily stored and reused for many years</li> </ul>	<ul style="list-style-type: none"> <li>• If netting is installed carefully, it should last for a number of years.</li> </ul>
Effectiveness	<ul style="list-style-type: none"> <li>• Good longevity and effectiveness with minimum need for repair if properly installed.</li> <li>• Cost effectiveness reduced by if special fitting around protrusions requires extensive labor.</li> </ul>	<ul style="list-style-type: none"> <li>• Netting and its installation materials are relatively inexpensive. Cost effectiveness is markedly lowered, however, by the labor needed to properly install it and ensure that it remains in good repair.</li> </ul>
Installation		
Method	<ul style="list-style-type: none"> <li>• Bird Slide comes in 4' lengths and will fit effectively on horizontal surfaces up to 5 and</li> </ul>	<ul style="list-style-type: none"> <li>• Excellent detailed instructions on netting installation are available at:</li> </ul>

Product	Corner Slope	Netting
	<p>7/8 inches wide. The product can be bonded and stacked with a second slide for use on wider surfaces.</p> <ul style="list-style-type: none"> <li>• Narrow surfaces may require the Bird Slide trim area to be cut—the goal is for the "slide"—the hypotenuse of the triangle to be just long enough that the horizontal leg of the triangle covers the entire horizontal surface to be protected..</li> <li>• Adhesive silicone #2 is applied in holes drilled every 12" in the slide and as a bead the full length of the slide.</li> <li>• Fiberglass panels are available in 4-12 oz weights. Smooth and translucent panels are 4' and 5' wide and of any length; Smooth and opaque panels are 4' wide and 8'-12' long.</li> <li>• Permanent positioning of an angle iron with a lip on the ceiling and on the wall or abutment would allow the fiberglass panels to be "popped" into place by flexing them. They could be readily replaced as needed.</li> </ul>	<p><a href="http://www.nixalite.com/installbirdnetting.aspx">http://www.nixalite.com/installbirdnetting.aspx</a> and at links from that web page.</p> <ul style="list-style-type: none"> <li>• Information is given on how to install a cable support system, how to overlap seams to make a net larger, how to fit a net around obstructions, and how to fasten the perimeter of the net and support it internally.</li> <li>• Support cables are recommended every 25' unless there are sufficient overhead support to tie to frequently.</li> </ul>
Frequency	<ul style="list-style-type: none"> <li>• The angle iron should last for many years.</li> <li>• The Bird Slide and fiberglass both would eventually require replacement. For a permanent installation, this would occur infrequently since brittleness from UV would not be a detriment while the product remains in place.</li> </ul>	<ul style="list-style-type: none"> <li>• As needed. Minor repair of holes and snags may be possible while the net is in place.</li> <li>• If the net must be taken down for repair, it may be most cost effective to simply replace it.</li> </ul>
Ease	<ul style="list-style-type: none"> <li>• Very easy to install. If Bird Slide and adhesive are used, they are easy to install.</li> <li>• If fiberglass panels are used, installing the</li> </ul>	<ul style="list-style-type: none"> <li>• Labor intensive since the netting must be fastened so that it has no gaps, tears, wrinkles or excessive sag.</li> </ul>

<b>Product</b>	<b>Corner Slope</b>	<b>Netting</b>
	<p>angle iron would be more labor intensive, but the panels could be readily replaced as needed.</p> <ul style="list-style-type: none"> <li>For both products the difficulty of installation increases with the complexity of the surface to be covered. If there are protrusions, the product needs to be cut and fitted around them.</li> </ul>	<ul style="list-style-type: none"> <li>Installation can be difficult beneath tall bridges or where water flows right up to a bridge abutment. Because the net lacks structure, it must be carried between fastening points and handled carefully.</li> </ul>
Maintenance		
Requirements	<ul style="list-style-type: none"> <li>Both Bird Slide plastic and fiberglass panels would eventually lose their flexibility due to UV exposure and would need to be replaced. This should occur infrequently in a permanent installation, however.</li> </ul>	<ul style="list-style-type: none"> <li>Because of the potential for birds and other animals to become trapped in the netting, it should be checked frequently to be sure it is taut and safe.</li> </ul>
Cost	<ul style="list-style-type: none"> <li>Same as initial investment for Bird Slide and fiberglass panels</li> </ul>	<ul style="list-style-type: none"> <li>Minor repairs can be made in situ by hand. If the net must be taken down to repair it, replacement may be more cost effective.</li> </ul>
Ease	<ul style="list-style-type: none"> <li>Little maintenance required except for occasional panel replacement.</li> </ul>	<ul style="list-style-type: none"> <li>Minor repairs are easily done but more substantial repairs can be labor intensive.</li> </ul>
Availability	<ul style="list-style-type: none"> <li>Available</li> </ul>	<ul style="list-style-type: none"> <li>Readily available.</li> </ul>
Technology		
Public Acceptance	<ul style="list-style-type: none"> <li>High</li> </ul>	<ul style="list-style-type: none"> <li>High.</li> </ul>
Acceptability	<ul style="list-style-type: none"> <li>High</li> </ul>	<ul style="list-style-type: none"> <li>High.</li> </ul>
Constructability	<ul style="list-style-type: none"> <li>High</li> </ul>	<ul style="list-style-type: none"> <li>Readily shaped to fit diverse sites.</li> </ul>
Compliance with Regulations	<ul style="list-style-type: none"> <li>High</li> </ul>	<ul style="list-style-type: none"> <li>Yes.</li> </ul>
Compliance with Environmental Requirements	<ul style="list-style-type: none"> <li>High</li> </ul>	<ul style="list-style-type: none"> <li>Yes.</li> </ul>
Other?	<ul style="list-style-type: none"> <li>NA</li> </ul>	<ul style="list-style-type: none"> <li>NA</li> </ul>
Summary		
Advantages	<ul style="list-style-type: none"> <li>Highly effective at deterring nesting.</li> </ul>	<ul style="list-style-type: none"> <li>Netting and its installation materials are</li> </ul>

<b>Product</b>	<b>Corner Slope</b>	<b>Netting</b>
	<ul style="list-style-type: none"> <li>• Aesthetic installation</li> <li>• Easy installation of Bird Slide.</li> <li>• Easy installation of fiberglass panels once angle iron is in place.</li> <li>• Fiber glass panels are relatively inexpensive.</li> </ul>	<p>relatively inexpensive.</p> <ul style="list-style-type: none"> <li>• Netting can be shaped to work in nearly all situations.</li> <li>• When properly installed, netting is highly effective as a deterrent to roosting and nesting.</li> </ul>
Disadvantages	<ul style="list-style-type: none"> <li>• Installation of the Bird Slide may labor intensive if there are protrusions that must be worked around by cutting the Bird Slide and custom fitting it to the site.</li> <li>• Installation of the angle iron may be labor intensive, depending on the weight and material used and whether there are protrusions that must be worked around.</li> </ul>	<ul style="list-style-type: none"> <li>• Installation is labor intensive and may be difficult in some situations.</li> <li>• Because the net is made of fabric, it needs to be replaced more frequently than deterrents made of metal or other more stable materials. Metal screening or chicken wire would last longer than fabric net, but would still suffer from the other disadvantages of netting.</li> <li>• If not properly installed and maintained, netting can cause mortality in birds and other species.</li> </ul>

**Table 3f. Evaluation Criteria for Pigeon Dropping/Nesting Solutions – Removal by Predators/Trapping.**

Product	Predators	Trapping
Source	<ul style="list-style-type: none"> <li>• The primary natural predators of pigeons are raptors, many of which are threatened/endangered.</li> <li>• Other omnivores and carnivores that survive in an urban environment (e.g., cats, foxes, skunks, raccoons) may also prey somewhat less successfully on pigeon adults, and eat eggs or young when they are encountered.</li> <li>• Native species of raptors are not commercially available. Raptors can be attracted to a vicinity by establishing inviting artificial platforms for some species. In addition, young raptors that are being raised in captivity for reintroduction to the wild may be established on platforms prior to fledging in the hope that they will return to that location to nest when they mature. Close coordination with the US Fish and Wildlife Service is required for any such effort.</li> </ul>	<ul style="list-style-type: none"> <li>• Construction designs well presented in University of Florida IFAS Extension Article SSWEC117</li> <li>• Traps also commercially available at sites such as: <a href="http://www.critterriders.com/pigeon_trap.htm">http://www.critterriders.com/pigeon_trap.htm</a></li> </ul>
Effectiveness in Discouraging		
Roosting	<ul style="list-style-type: none"> <li>• If an actively nesting pair of raptors is successfully established, it is likely that the nearby pigeon population would be markedly reduced through actual predation and due to fear of predation.</li> <li>• Intensity of predation will be variable—highest when young raptors are close to fledging, and lowest during mid-winter when raptors may disperse.</li> </ul>	<ul style="list-style-type: none"> <li>• Because of the homing capability of pigeons, trapped pigeons must be killed. Simply releasing them some distance from the site where they are considered undesirable would not be effective. See the chemical control methods for a discussion of trapping using treated baits.</li> </ul>

<b>Product</b>	<b>Predators</b>	<b>Trapping</b>
	<ul style="list-style-type: none"> <li>• Would not eliminate population of pigeons or totally exclude them from specific roosting spots.</li> </ul>	
Nesting	<ul style="list-style-type: none"> <li>• See comment above regarding effectiveness in discouraging roosting.</li> </ul>	<ul style="list-style-type: none"> <li>• See comment above regarding effectiveness in discouraging roosting.</li> </ul>
Ease of Providing Needed Bridge Access	<ul style="list-style-type: none"> <li>• Establishment of nesting habitat would need to be done in close coordination with US Fish and Wildlife Service biologists if site is to be successful.</li> </ul>	<ul style="list-style-type: none"> <li>• To temporarily control pigeon numbers at a particular roost or nesting area, traps must be located where the birds using these areas typically feed.</li> <li>• Locations should be selected after watching the movements of the birds in question, and also where they are out of public view.</li> </ul>
Negative Impacts/Risks		
Humans	<ul style="list-style-type: none"> <li>• No detriment to people from predator establishment.</li> <li>• May be negative response from some members of the public if capture of pigeons by raptors is observed, particularly if the raptor is frightened off its kill before the pigeon is fully dead or consumed.</li> </ul>	<ul style="list-style-type: none"> <li>• No detriment to people from trapping.</li> <li>• Trapping is typically viewed negatively by the general public</li> </ul>
Birds	<ul style="list-style-type: none"> <li>• Most predation of raptors established on urban sites would be of pigeons, since they are the most abundant prey species.</li> </ul>	<ul style="list-style-type: none"> <li>• If trapping is done without use of chemically treated bait, any non-target species can be readily released when the pigeons are caught and killed.</li> <li>• If trapping is done using chemically treated bait, the traps must be carefully monitored. See the chemical control methods for discussion of trapping using treated baits.</li> </ul>
Environment	<ul style="list-style-type: none"> <li>• Establishment of additional nesting sites for</li> </ul>	<ul style="list-style-type: none"> <li>• Minimal (potential inadvertent mortality of</li> </ul>



<b>Product</b>	<b>Predators</b>	<b>Trapping</b>
	<p>raptors is ecologically beneficial.</p> <ul style="list-style-type: none"> <li>• Areas near roadways and traffic, however, may not be suitable because of the high risk of mortality to young raptors when they fledging and learning to fly.</li> <li>• Increasing the numbers of other species of urban predators (e.g., cats) is highly detrimental and undesirable, since such species are indiscriminant predators that prey on all protected bird and other species.</li> </ul>	<p>non-target species if trap is not properly designed and monitored)</p> <ul style="list-style-type: none"> <li>• No other impacts/risks unless chemically treated bait is used.</li> </ul>
Infrastructure	<ul style="list-style-type: none"> <li>• Minimal. Some additional droppings would occur in the immediate vicinity of the nest.</li> </ul>	<ul style="list-style-type: none"> <li>• None</li> </ul>
Cost		
Initial	<ul style="list-style-type: none"> <li>• Nest platform itself is of minimal cost.</li> <li>• Coordination with US Fish and Wildlife Service and would be time consuming.</li> </ul>	<ul style="list-style-type: none"> <li>• \$89.95 to \$199.95, depending on size and style. Traps can be moved from place to place, so no more than six (a number that can reasonably be monitored when all are in active use) should be needed.</li> </ul>
Maintenance	<ul style="list-style-type: none"> <li>• Little required.</li> <li>• Occasional inspection to be sure platform is secure</li> <li>• Potential need for removal of excessive nesting material every 5 years or so.</li> </ul>	<ul style="list-style-type: none"> <li>• Minimal if carefully stored.</li> </ul>
Replacement	<ul style="list-style-type: none"> <li>• Same as initial purchase.</li> </ul>	<ul style="list-style-type: none"> <li>• Same as initial purchase.</li> </ul>
Service Life	<ul style="list-style-type: none"> <li>• Long term.</li> </ul>	<ul style="list-style-type: none"> <li>• Long term</li> </ul>
Life-cycle	<ul style="list-style-type: none"> <li>• Should last many years.</li> </ul>	<ul style="list-style-type: none"> <li>• Should last many years if carefully stored and minor repairs are done as needed.</li> </ul>
Effectiveness	<ul style="list-style-type: none"> <li>• Moderately effective.</li> </ul>	<ul style="list-style-type: none"> <li>• Low, even though trapping is temporarily very effective. This is because populations</li> </ul>

Product	Predators	Trapping
		will rapidly rebound through recruitment from neighboring pigeon populations and through increased reproduction of birds remaining.
Installation		
Method	<ul style="list-style-type: none"> <li>• Careful selection of location so that artificial nest will be suitable for successful nesting effort.</li> <li>• Extensive coordination with US Fish and Wildlife Service biologists in establishing artificial nest.</li> <li>• If young birds are "hacked back" to the wild from the artificial nest, it is mostly likely to be subsequently used for nesting.</li> <li>• Hacking back is an elaborate process that requires the cooperation of many players. It also requires the availability of young birds and the willingness of those who are raising and releasing them to use the offered site.</li> <li>• The most appropriate species to be expected to prey on pigeons are peregrine and prairie falcons, although prairie falcons prefer open country and are less likely to use an urban site than peregrine falcons. Accipiters (e.g., goshawks and Cooper's hawks, sharp-shinned hawks), can also be expected to prey on pigeons, but are unlikely to accept an artificial nest platform in an urban setting for nesting. Some buteo's (e.g., Red-tailed hawk, ferruginous hawk) may take an occasional pigeon, but are less agile hunters and are</li> </ul>	<ul style="list-style-type: none"> <li>• Careful selection of location so that group of pigeons roosting/nesting in undesirable place is targeted and also to avoid public scrutiny.</li> </ul>

<b>Product</b>	<b>Predators</b>	<b>Trapping</b>
	unlikely to nest in an artificial nest in an urban setting.	
Frequency	<ul style="list-style-type: none"> <li>• Seldom</li> </ul>	<ul style="list-style-type: none"> <li>• As populations rebound.</li> </ul>
Ease	<ul style="list-style-type: none"> <li>• Readily installed.</li> <li>• Selection of a useable site that is attractive to and safe for the birds, successfully getting them fledged, and having them return successfully to breed are the hard parts.</li> </ul>	<ul style="list-style-type: none"> <li>• Site selection for targeted pigeon population will take time and careful observation.</li> <li>• Traps should be checked frequently, be shaded so birds do not overheat in summer, have water supplied, etc. so conditions inside trap are humane.</li> <li>• Labor intensive and distasteful approach, as pigeons must be killed/This is typically done by neck dislocation.</li> </ul>
Maintenance		
Requirements	<ul style="list-style-type: none"> <li>• Very occasional inspection and repair of platform.</li> <li>• Very occasional removal of excessive nesting material.</li> </ul>	<ul style="list-style-type: none"> <li>• Minor repair</li> </ul>
Cost	<ul style="list-style-type: none"> <li>• Minimal</li> </ul>	<ul style="list-style-type: none"> <li>• Minor</li> </ul>
Ease	<ul style="list-style-type: none"> <li>• Readily done.</li> </ul>	<ul style="list-style-type: none"> <li>• Readily done</li> </ul>
Availability	<ul style="list-style-type: none"> <li>• Most nest platforms are individually rather than commercially constructed. See plans such as those at:  <a href="http://www.raptor.cvm.umn.edu/raptor/education/lessonplans/lessons4-9/lesson8/osprey_platform/home.html">http://www.raptor.cvm.umn.edu/raptor/education/lessonplans/lessons4-9/lesson8/osprey_platform/home.html</a>;  <a href="http://www.derby.gov.uk/LeisureCulture/MuseumsGalleries/EnvironmentalProjects/Technical Info.htm">http://www.derby.gov.uk/LeisureCulture/MuseumsGalleries/EnvironmentalProjects/Technical Info.htm</a>;  <a href="http://www.eei.org/industry_issues/environe">http://www.eei.org/industry_issues/environe</a></li> </ul>	<ul style="list-style-type: none"> <li>• Readily available.</li> </ul>

<b>Product</b>	<b>Predators</b>	<b>Trapping</b>
	<a href="#">nt/land/wildlife_and_endangered_species/AvianProtectionPlanGuidelines.pdf</a>	
Technology		
Public Acceptance	<ul style="list-style-type: none"> <li>• High</li> </ul>	<ul style="list-style-type: none"> <li>• Low</li> </ul>
Acceptability	<ul style="list-style-type: none"> <li>• High</li> </ul>	<ul style="list-style-type: none"> <li>• Low</li> </ul>
Constructability	<ul style="list-style-type: none"> <li>• Easily done.</li> </ul>	<ul style="list-style-type: none"> <li>• Easily done</li> </ul>
Compliance with Regulations	<ul style="list-style-type: none"> <li>• Close coordination with US Fish and Wildlife Service required.</li> </ul>	<ul style="list-style-type: none"> <li>• Trapping pigeons is not regulated because the species is not protected.</li> <li>• Any chemicals used must be EPA approved and often can only be applied by a licensed operator.</li> <li>• Because of the potential for impacts on non-target species that are protected, coordination with the US Fish and Wildlife Service and Colorado Division of Wildlife should be done.</li> </ul>
Compliance with Environmental Requirements	<ul style="list-style-type: none"> <li>• See above.</li> </ul>	<ul style="list-style-type: none"> <li>• See above.</li> </ul>
Other?	<ul style="list-style-type: none"> <li>• NA</li> </ul>	<ul style="list-style-type: none"> <li>• NA</li> </ul>
Summary		
Advantages	<ul style="list-style-type: none"> <li>• Benefits raptor species that have declining populations</li> <li>• Ecologically sound approach.</li> </ul>	<ul style="list-style-type: none"> <li>• Easy to do</li> <li>• Inexpensive but labor intensive.</li> <li>• Produces rapid (though temporary) results</li> </ul>
Disadvantages	<ul style="list-style-type: none"> <li>• Logistics are difficult due to need for extensive coordination and risks associated with successful long term use of nest.</li> <li>• Will reduce but not eliminate pigeon populations</li> </ul>	<ul style="list-style-type: none"> <li>• Is not effective in the long term</li> <li>• Low public acceptance, and could result in public outcry and opposition by organized groups if given potential spin by the media.</li> </ul>

<b>Product</b>	<b>Predators</b>	<b>Trapping</b>
	<ul style="list-style-type: none"><li data-bbox="716 297 1308 423">• Sites must be carefully selected not only to be acceptable to the birds, but to result in both successful nesting and fledging of vulnerable young birds.</li></ul>	

**Table 3g. Evaluation Criteria for Pigeon Dropping/Nesting Solutions – Removal by Shooting/Egg Removal.**

<b>Product</b>	<b>Shooting</b>	<b>Egg Removal</b>
Source and Discussion	<ul style="list-style-type: none"> <li>• Not an acceptable approach in an urban environment</li> <li>• Results are similar to results of trapping—temporarily reduced numbers followed rapidly by resurging population due to recruitment from neighboring populations and increased nesting.</li> <li>• Not a sufficiently viable option to be considered further.</li> </ul>	<ul style="list-style-type: none"> <li>• Removal of eggs is successful only if artificial eggs are substituted so that the adults continue to incubate the "eggs" rather than simply laying new ones. This will result in reduced reproduction and lowered population if it is done repeatedly and consistently. Some recruitment from neighboring populations will still occur.</li> <li>• Removal of eggs is only a reasonable option if pigeons are nesting close together in multi-unit housing constructed so that eggs can readily be exchanged.</li> <li>• A program that controls public provision of food for pigeons, encourages them to nest in constructed housing, and population control through egg removal has been used in European cities with touted success.</li> <li>• Not a sufficiently viable option to be considered further.</li> </ul>

**Table 3h. Evaluation Criteria for Pigeon Dropping/Nesting Solutions – Removal by Nest Removal/Food Removal.**

<b>Product</b>	<b>Nest Removal</b>	<b>Food Removal</b>
Source and Discussion	<ul style="list-style-type: none"> <li>• Nest removal simply results in the pigeons rebuilding their nests.</li> <li>• In a battle between maintenance crews that have other responsibilities, and pigeons with a strong urge to build their nests, the pigeons are most likely to win out.</li> <li>• Not considered a sufficiently viable option to consider further.</li> </ul>	<ul style="list-style-type: none"> <li>• The populations of all species are controlled by one or more limiting factors—insufficient food, water, roosting or nesting sites, mates, etc.</li> <li>• Most of the deterrents considered in this study would limit access to roosting/nesting sites, or modify them so they are no longer suitable for use by pigeons.</li> <li>• The approach next most likely to have an effect is the removal of food sources for pigeons.</li> <li>• Food removal would effectively reduce pigeon populations, but would not exclude them from specific roosting or nesting sites where they are undesirable.</li> <li>• However, controlling public behavior to make (intentional or unintentional) food sources unavailable is beyond the purview of CDOT.</li> <li>• Therefore, this is not considered a sufficiently viable option to consider further.</li> </ul>

**Table 3i. Evaluation Criteria for Pigeon Dropping/Nesting Solutions – Scare by Static and Moving Figures.**

<b>Product</b>	<b>Static Figures (owl, snake, scarecrow, etc.)</b>	<b>Moving Figures (twisting streamers, holographic eyes, etc.)</b>
Source	<ul style="list-style-type: none"> <li>Gardenocity (see: <a href="http://www.provenrepellents.com/products.php?catID=2">http://www.provenrepellents.com/products.php?catID=2</a>) has products such as several types of fake owls, rubber snakes.</li> </ul>	<ul style="list-style-type: none"> <li>Nixalite, Inc., (<a href="http://www.nixalite.com/NixaliteSiteMap.aspx">http://www.nixalite.com/NixaliteSiteMap.aspx</a>) and others have products such as the following: <ul style="list-style-type: none"> <li>Predator eye</li> <li>Scarecrow motion activated sprinkler effective against medium to large birds</li> </ul> </li> </ul>
Effectiveness in Discouraging		
Roosting	<ul style="list-style-type: none"> <li>Such figures may work for a very short time, but pigeons rapid acclimate to them.</li> </ul>	<ul style="list-style-type: none"> <li>Moving figures may work somewhat longer than static figures, but ultimately pigeons acclimate to them as well.</li> </ul>
Nesting	<ul style="list-style-type: none"> <li>See comment regarding roosting.</li> </ul>	<ul style="list-style-type: none"> <li>See comment regarding roosting.</li> </ul>
Ease of Providing Needed Bridge Access	<ul style="list-style-type: none"> <li>Such products are typical places or hung where ever convenient.</li> </ul>	<ul style="list-style-type: none"> <li>Such products are typical places or hung where ever convenient.</li> </ul>
Negative Impacts/Risks		
Humans	<ul style="list-style-type: none"> <li>None.</li> </ul>	<ul style="list-style-type: none"> <li>None.</li> </ul>
Birds	<ul style="list-style-type: none"> <li>None.</li> </ul>	<ul style="list-style-type: none"> <li>None.</li> </ul>
Environment	<ul style="list-style-type: none"> <li>Minimal, although such products may deteriorate and contribute small indigestible parts to the environment.</li> <li>Such debris contributes to mortality of a number of species.</li> </ul>	<ul style="list-style-type: none"> <li>Minimal, although such products may deteriorate and contribute small indigestible parts to the environment. This is particularly true of moving figures, which have articulations that can come apart. Such debris contributes to mortality of a number of species.</li> </ul>
Infrastructure	<ul style="list-style-type: none"> <li>None.</li> </ul>	<ul style="list-style-type: none"> <li>None.</li> </ul>



<b>Product</b>	<b>Static Figures (owl, snake, scarecrow, etc.)</b>	<b>Moving Figures (twisting streamers, holographic eyes, etc.)</b>
Cost		
Initial	<ul style="list-style-type: none"> <li>• Rotating head owl decoy-\$27.99</li> <li>• Dalen owl decoy-\$16.99</li> <li>• Owl scarecrow-\$8.49</li> <li>• Snake scarecrow-\$8.49</li> </ul>	<ul style="list-style-type: none"> <li>• Predator eye (12; yellow)=\$119.76</li> <li>• Scarecrow motion activated sprinkler (12)=\$888.00</li> <li>• Garden Defense Electronic Owl-\$41.99</li> <li>• Prowler owl decoy-\$59.00</li> </ul>
Maintenance	<ul style="list-style-type: none"> <li>• None.</li> </ul>	<ul style="list-style-type: none"> <li>• Battery replacement in some products.</li> </ul>
Replacement	<ul style="list-style-type: none"> <li>• Same as initial purchase.</li> </ul>	<ul style="list-style-type: none"> <li>• Same as initial purchase.</li> </ul>
Service Life	<ul style="list-style-type: none"> <li>• Several years</li> </ul>	<ul style="list-style-type: none"> <li>• Less than several years because articulation are likely to fail.</li> </ul>
Life-cycle	<ul style="list-style-type: none"> <li>• May look unrealistic long before shape and form are lost due to fading paint, etc.</li> </ul>	<ul style="list-style-type: none"> <li>• Likely to come apart before looks unrealistic.</li> </ul>
Effectiveness	<ul style="list-style-type: none"> <li>• Low.</li> </ul>	<ul style="list-style-type: none"> <li>• Low.</li> </ul>
Installation		
Method	<ul style="list-style-type: none"> <li>• Usually attached to a pole or placed on a platform.</li> </ul>	<ul style="list-style-type: none"> <li>• Often suspended from a pole, wire, or mounting arm so can move freely.</li> </ul>
Frequency	<ul style="list-style-type: none"> <li>• Every several years as replacement will be needed.</li> </ul>	<ul style="list-style-type: none"> <li>• More frequently than static figures.</li> </ul>
Ease	<ul style="list-style-type: none"> <li>• High.</li> </ul>	<ul style="list-style-type: none"> <li>• High.</li> </ul>
Maintenance		
Requirements	<ul style="list-style-type: none"> <li>• None, except that should be repositioned frequently to have any chance of effectiveness.</li> </ul>	<ul style="list-style-type: none"> <li>• See comment for static figures.</li> </ul>
Cost	<ul style="list-style-type: none"> <li>• Likely not repairable.</li> </ul>	<ul style="list-style-type: none"> <li>• Likely not repairable.</li> </ul>
Ease	<ul style="list-style-type: none"> <li>• NA</li> </ul>	<ul style="list-style-type: none"> <li>• NA</li> </ul>
Availability	<ul style="list-style-type: none"> <li>• Readily available.</li> </ul>	<ul style="list-style-type: none"> <li>• Readily available.</li> </ul>

<b>Product</b>	<b>Static Figures (owl, snake, scarecrow, etc.)</b>	<b>Moving Figures (twisting streamers, holographic eyes, etc.)</b>
Technology		
Public Acceptance	<ul style="list-style-type: none"> <li>• Hi, especially including the chuckle factor.</li> </ul>	<ul style="list-style-type: none"> <li>• See comment for static figures.</li> </ul>
Acceptability	<ul style="list-style-type: none"> <li>• High.</li> </ul>	<ul style="list-style-type: none"> <li>• High.</li> </ul>
Constructability	<ul style="list-style-type: none"> <li>• High.</li> </ul>	<ul style="list-style-type: none"> <li>• High.</li> </ul>
Compliance with Regulations	<ul style="list-style-type: none"> <li>• Yes.</li> </ul>	<ul style="list-style-type: none"> <li>• Yes.</li> </ul>
Compliance with Environmental Requirements	<ul style="list-style-type: none"> <li>• Yes.</li> </ul>	<ul style="list-style-type: none"> <li>• Yes.</li> </ul>
Other?	<ul style="list-style-type: none"> <li>• NA</li> </ul>	<ul style="list-style-type: none"> <li>• NA</li> </ul>
Summary		
Advantages	<ul style="list-style-type: none"> <li>• Easy to install and inexpensive.</li> </ul>	<ul style="list-style-type: none"> <li>• Easy to install and relatively inexpensive.</li> </ul>
Disadvantages	<ul style="list-style-type: none"> <li>• Very low probably of any but fleeting success.</li> </ul>	<ul style="list-style-type: none"> <li>• Slightly more effective than static figures, but still very low probability of any but fleeting success.</li> </ul>

**Table 3j. Evaluation Criteria for Pigeon Dropping/Nesting Solutions – Scare by Noises.**

<b>Product</b>	<b>Noises</b>
Source and Discussion	<ul style="list-style-type: none"> <li>• Noises that could be used to deter the presence of pigeons can be subdivided into two types: those that can also be heard by people, and those that people cannot hear.</li> <li>• Noises that can also be heard by people have been used with some success by transportation groups to deter large numbers of migrating birds from nesting on structures (e.g., <a href="http://www.oregon.gov/ODOT/HWY/REGION1/news/OrchardCannonsonI5Bridge092506.pdf">http://www.oregon.gov/ODOT/HWY/REGION1/news/OrchardCannonsonI5Bridge092506.pdf</a>). However, they are most effective on species and individuals that have not established strong site fidelity, and where/when people are exposed to such noises for only a short period of time. In a contest between pigeon acclimation and unacceptable human annoyance, the pigeons would win.</li> <li>• Loud, erratic noises that can be heard by people are not considered an acceptable solution and are not considered further.</li> <li>• Ultrasonic noises (noises above the human hearing range) have also been tried to deter birds from using specific sites. A publication by the Arkansas State Highway and Transportation Department (TRC-0501 Evaluation of Passive Bird Deterrent Devices to Minimize Nesting on Bridges and Culverts—not available online but present on the CD associated with this Interim Report) presented an excellent and well documented study of the effectiveness of ultrasonic devices on deterring barn and cliff swallows from nesting on structures. The devices were found to be useless.</li> <li>• It is not expected that the effect of ultrasonic devices on pigeons would differ. Ultrasonic devices do not warrant further consideration.</li> </ul>

**Tables 4a-4f. Evaluation of Temporary Swallow Nesting Deterrents.**

**Table 4a. Evaluation Criteria for Temporary Swallow Nesting Solutions-Chemical.**

<b>Product</b>	<b>Methyl Anthranilate</b>	<b>Alpha Chloralose, Avitrol, and other chemicals used in baits</b>
Source	<ul style="list-style-type: none"> <li>• BirdTec, Inc.</li> <li>• Nixalite, Inc.</li> </ul>	<ul style="list-style-type: none"> <li>• Illegal and inappropriate for use on protected species.</li> <li>• Publically unacceptable for use on unprotected species.</li> </ul>
Effectiveness in Discouraging Nesting		
Nesting	<ul style="list-style-type: none"> <li>• Unknown. May be more effective as a deterrent for roosting than nesting, as when birds are nest building, they move in and out of the site repeatedly and wouldn't get the full effect of the chemical until they were sitting on the nest, by which time the urge to stay would be at its peak.</li> </ul>	<ul style="list-style-type: none"> <li>• NA</li> </ul>
Ease of Providing Needed Bridge Access	<ul style="list-style-type: none"> <li>• Entire extent of exclusion site would need to be accessed to install tubing. Motor could be placed in an accessible location and connected to perforated tubing with nonperforated tubing where exclusion was not needed.</li> </ul>	<ul style="list-style-type: none"> <li>• NA</li> </ul>
Negative Impacts/Risks		
Humans	<ul style="list-style-type: none"> <li>• None. Used in food stuffs with artificial grape flavors. Used as deterrent in fruit crop fields.</li> </ul>	<ul style="list-style-type: none"> <li>• NA</li> </ul>
Birds	<ul style="list-style-type: none"> <li>• Irritant, but apparently nontoxic; BirdTec looking for old paper citing tests on birds.</li> </ul>	<ul style="list-style-type: none"> <li>• NA</li> </ul>
Environment	<ul style="list-style-type: none"> <li>• None; naturally occurring substance that disperses.</li> </ul>	<ul style="list-style-type: none"> <li>• NA</li> </ul>

<b>Product</b>	<b>Methyl Anthranilate</b>	<b>Alpha Chloralose, Avitrol, and other chemicals used in baits</b>
Infrastructure	<ul style="list-style-type: none"> <li>• None</li> </ul>	<ul style="list-style-type: none"> <li>• NA</li> </ul>
Cost		
Initial	<ul style="list-style-type: none"> <li>• Nixalite Bird Buffer (applies through a single applicator nozzle=max 1 acre protection)</li> <li>• fogforce liquid (.5 gal/month; 6 gal/yr)=\$780.00</li> <li>• hard poly cover=\$259.00</li> <li>• windicator haze=\$10.69</li> <li>• haze generator=\$8,685.00</li> <li>• Bird-Tec (applies through perforated tubing); product cost not yet determined.</li> </ul>	<ul style="list-style-type: none"> <li>• NA</li> </ul>
Maintenance	<ul style="list-style-type: none"> <li>• Monthly replenishment of liquid to be dispersed as a haze.</li> </ul>	<ul style="list-style-type: none"> <li>• NA</li> </ul>
Replacement	<ul style="list-style-type: none"> <li>• Anecdotal evidence of 4 year operation. Relatively new product, without long term performance data.</li> </ul>	<ul style="list-style-type: none"> <li>• NA</li> </ul>
Service Life	<ul style="list-style-type: none"> <li>• Unknown</li> </ul>	<ul style="list-style-type: none"> <li>• NA</li> </ul>
Life-cycle	<ul style="list-style-type: none"> <li>• 4 plus years</li> </ul>	<ul style="list-style-type: none"> <li>• NA</li> </ul>
Effectiveness	<ul style="list-style-type: none"> <li>• Most effective in enclosed spaces. May also be effective in open areas since application is intermittent and can be varied using a timer.</li> <li>• Appears to be highly effective based on testimonials. This is a relatively new product without a long track record in diverse locations.</li> </ul>	<ul style="list-style-type: none"> <li>• NA</li> </ul>
Installation		
Method	<ul style="list-style-type: none"> <li>• Use existing power source. Solar or generator also possible. Heater is part of</li> </ul>	<ul style="list-style-type: none"> <li>• NA</li> </ul>

<b>Product</b>	<b>Methyl Anthranilate</b>	<b>Alpha Chloralose, Avitrol, and other chemicals used in baits</b>
	installations where temperature falls below 20o gel point. Successful in Norway and Chicago.	
Frequency	<ul style="list-style-type: none"> <li>Once installed system can be set for variable operation. Default is 30 sec. on, 1 min. purge, 5 min. off. Systems in place have operated for 4.5 years to date.</li> </ul>	<ul style="list-style-type: none"> <li>NA</li> </ul>
Ease	<ul style="list-style-type: none"> <li>Tubing must be placed everywhere the chemical is to be released. Need for power source may be a deterrent.</li> </ul>	<ul style="list-style-type: none"> <li>NA</li> </ul>
Maintenance		
Requirements	<ul style="list-style-type: none"> <li>Refill of chemical every 45-60 days. Likely need to replace tubing after several years</li> </ul>	<ul style="list-style-type: none"> <li>NA</li> </ul>
Cost	<ul style="list-style-type: none"> <li>Fogforce liquid (.5 gal/month; 6 gal/yr)=\$780.00</li> <li>Cost from Bird-Tec expected to be similar.</li> </ul>	<ul style="list-style-type: none"> <li>NA</li> </ul>
Ease	<ul style="list-style-type: none"> <li>Readily refilled on monthly basis.</li> </ul>	<ul style="list-style-type: none"> <li>NA</li> </ul>
Availability	<ul style="list-style-type: none"> <li>Readily available from two suppliers who have differing application methods.</li> </ul>	<ul style="list-style-type: none"> <li>NA</li> </ul>
Technology		
Public Acceptance	<ul style="list-style-type: none"> <li>Good—presence of a grape odor</li> </ul>	<ul style="list-style-type: none"> <li>NA</li> </ul>
Acceptability	<ul style="list-style-type: none"> <li>Good—odor is used</li> </ul>	<ul style="list-style-type: none"> <li>NA</li> </ul>
Constructability	<ul style="list-style-type: none"> <li>Because chemical is aerosolized from tubing, long runs of tubing are needed to cover the exclusion area. Motor will support up to 800 feet of tubing.</li> </ul>	<ul style="list-style-type: none"> <li>NA</li> </ul>
Compliance with Regulations	<ul style="list-style-type: none"> <li>This chemical is not a controlled substance.</li> </ul>	<ul style="list-style-type: none"> <li>NA</li> </ul>

<b>Product</b>	<b>Methyl Anthranilate</b>	<b>Alpha Chloralose, Avitrol, and other chemicals used in baits</b>
Compliance with Environmental Requirements	<ul style="list-style-type: none"> <li>• EPA has exempted from need to develop a tolerance level. Are no environmental restrictions</li> <li>• Nonetheless, coordination with both EPA and US Fish and Wildlife Service are recommended to ensure that use of this chemical on a protected species is acceptable.</li> </ul>	<ul style="list-style-type: none"> <li>• NA</li> </ul>
Other?	<ul style="list-style-type: none"> <li>• None</li> </ul>	<ul style="list-style-type: none"> <li>• NA</li> </ul>
<b>Summary</b>		
Advantages	<ul style="list-style-type: none"> <li>• Application can be to very specific area, nontoxic, nonstructural, application readily started/stopped.</li> </ul>	<ul style="list-style-type: none"> <li>• NA</li> </ul>
Disadvantages	<ul style="list-style-type: none"> <li>• Need for power; may not be effective as a nesting deterrent</li> </ul>	<ul style="list-style-type: none"> <li>• NA</li> </ul>

**Table 4b. Evaluation Criteria for Temporary Swallow Nesting Solutions - Coatings.**

<b>Product</b>	<b>Tanglefoot</b>	<b>Bird B Gone Gel</b>	<b>AeroKret and Other Permanent Coatings</b>
Source	<ul style="list-style-type: none"> <li>• Nixalite</li> </ul>	<ul style="list-style-type: none"> <li>• Bird B Gone Inc.</li> </ul>	<ul style="list-style-type: none"> <li>• Analytical Services &amp; Materials, Inc.</li> </ul>
Effectiveness in Discouraging			
Nesting	<ul style="list-style-type: none"> <li>• Discourages birds from landing on all types of surfaces</li> <li>• Registered with EPA for use against pigeons, starlings, and sparrows. EPA requires the following label on containing polybutene, the active ingredient in Tanglefoot: "Small birds may become fatally entrapped by this tacky repellent. To reduce hazards to legally protected species, and to avoid noncompliance with the Federal Migratory Bird Treaty Act, follow all instructions in the Directions For Use. "</li> <li>• Chemical roost repellents (polybutenes, sticky pastes, sprays) have not been proven effective against swallows and may actually improve nest adherence. Cliff swallow nests built over a sticky repellent have been observed. This product is mentioned by the Colorado State Extension</li> </ul>	<ul style="list-style-type: none"> <li>• Comments on Tanglefoot apply equally to Bird B Gone gel.</li> </ul>	<ul style="list-style-type: none"> <li>• Unknown whether surface would be slick enough to prevent mud from adhering (see comment at left). Is a permanent application, which is not what is needed in the case of swallows. If product were to allow mud to stick, but also be washed off easily, could facilitate cleaning of all nest residue in those years when nesting was not desired. However, some physical "lockout" mechanism would likely still be needed, so ease of cleaning might be unnecessary.</li> </ul>



<b>Product</b>	<b>Tanglefoot</b>	<b>Bird B Gone Gel</b>	<b>AeroKret and Other Permanent Coatings</b>
	<p>Service so is assumedly acceptable in this state.</p> <ul style="list-style-type: none"> <li>• Could potentially trap swallows because they are small and light bodied.</li> <li>• This is not an appropriate product for use with swallows.</li> </ul>		
Ease of Providing Needed Bridge Access	<ul style="list-style-type: none"> <li>• NA</li> </ul>	<ul style="list-style-type: none"> <li>• NA</li> </ul>	<ul style="list-style-type: none"> <li>• Both primer and topcoat may be sprayed on a surface that has been washed, degreased, and then sand blasted or scuffed with an abrasive disc</li> <li>• Most practical application would be to new bridge or other structure components</li> <li>• On existing structures, surface preparation in the field may be a problem, but ability to spray primer and topcoat facilitates product application.</li> </ul>
Negative Impacts/Risks			
Humans	<ul style="list-style-type: none"> <li>• NA</li> </ul>	<ul style="list-style-type: none"> <li>• NA</li> </ul>	<ul style="list-style-type: none"> <li>• Products used in surface preparation may require PPE</li> <li>• Respiratory protection required during product application</li> <li>• None once product has cured</li> </ul>
Birds	<ul style="list-style-type: none"> <li>• NA</li> </ul>	<ul style="list-style-type: none"> <li>• NA</li> </ul>	<ul style="list-style-type: none"> <li>• None once product has cured</li> </ul>
Environment	<ul style="list-style-type: none"> <li>• NA</li> </ul>	<ul style="list-style-type: none"> <li>• NA</li> </ul>	<ul style="list-style-type: none"> <li>• None once product has cured. Final product is inert and non-toxic.</li> <li>• If product were to be applied in the field, surface preparation products</li> </ul>

<b>Product</b>	<b>Tanglefoot</b>	<b>Bird B Gone Gel</b>	<b>AeroKret and Other Permanent Coatings</b>
			could adversely affect the environment (e.g., material on surfaces could wash into surface waters and degreasers are likely to be environmentally controlled substances).
Infrastructure	<ul style="list-style-type: none"> <li>• NA</li> </ul>	<ul style="list-style-type: none"> <li>• NA</li> </ul>	<ul style="list-style-type: none"> <li>• Once product is applied infrastructure will benefit</li> </ul>
Cost			
Initial	<ul style="list-style-type: none"> <li>• NA</li> </ul>	<ul style="list-style-type: none"> <li>• NA</li> </ul>	<ul style="list-style-type: none"> <li>• Dependant on volume purchased.</li> </ul>
Maintenance	<ul style="list-style-type: none"> <li>• NA</li> </ul>	<ul style="list-style-type: none"> <li>• NA</li> </ul>	<ul style="list-style-type: none"> <li>• Expected to be long term solution.</li> <li>• For example, after 1 year in seawater the coating on a boat hull remained adherent, smooth, and free of barnacles.</li> </ul>
Replacement	<ul style="list-style-type: none"> <li>• NA</li> </ul>	<ul style="list-style-type: none"> <li>• NA</li> </ul>	<ul style="list-style-type: none"> <li>• None anticipated.</li> </ul>
Service Life	<ul style="list-style-type: none"> <li>• NA</li> </ul>	<ul style="list-style-type: none"> <li>• NA</li> </ul>	<ul style="list-style-type: none"> <li>• Unknown.</li> </ul>
Life-cycle	<ul style="list-style-type: none"> <li>• NA</li> </ul>	<ul style="list-style-type: none"> <li>• NA</li> </ul>	<ul style="list-style-type: none"> <li>• Unknown.</li> </ul>
Effectiveness	<ul style="list-style-type: none"> <li>• NA</li> </ul>	<ul style="list-style-type: none"> <li>• NA</li> </ul>	<ul style="list-style-type: none"> <li>• May not be cost effective simply as an aid to removal of nests in years when they are temporarily to be deterred.</li> </ul>
Installation			
Method	<ul style="list-style-type: none"> <li>• NA</li> </ul>	<ul style="list-style-type: none"> <li>• NA</li> </ul>	<ul style="list-style-type: none"> <li>• Clean surface as noted above.</li> <li>• Spray both primer and topcoat.</li> </ul>
Frequency	<ul style="list-style-type: none"> <li>• NA</li> </ul>	<ul style="list-style-type: none"> <li>• NA</li> </ul>	<ul style="list-style-type: none"> <li>• Single application anticipated.</li> </ul>
Ease	<ul style="list-style-type: none"> <li>• NA</li> </ul>	<ul style="list-style-type: none"> <li>• NA</li> </ul>	<ul style="list-style-type: none"> <li>• Readily applied once surface has been prepared.</li> </ul>
Maintenance			

<b>Product</b>	<b>Tanglefoot</b>	<b>Bird B Gone Gel</b>	<b>AeroKret and Other Permanent Coatings</b>
Requirements	<ul style="list-style-type: none"> <li>Repeated reapplication necessary as gel runs off or becomes coated with dirt. Repellent must be removed with a solvent.</li> </ul>	<ul style="list-style-type: none"> <li>NA</li> </ul>	<ul style="list-style-type: none"> <li>None anticipated.</li> <li>Need for maintenance in local setting unknown.</li> </ul>
Cost	<ul style="list-style-type: none"> <li>NA</li> </ul>	<ul style="list-style-type: none"> <li>NA</li> </ul>	<ul style="list-style-type: none"> <li>See above.</li> </ul>
Ease	<ul style="list-style-type: none"> <li>NA</li> </ul>	<ul style="list-style-type: none"> <li>NA</li> </ul>	<ul style="list-style-type: none"> <li>See above.</li> </ul>
Availability	<ul style="list-style-type: none"> <li>NA</li> </ul>	<ul style="list-style-type: none"> <li>NA</li> </ul>	<ul style="list-style-type: none"> <li>Readily available from Analytical Services &amp; Materials, Inc.</li> </ul>
Technology			
Public Acceptance	<ul style="list-style-type: none"> <li>NA</li> </ul>	<ul style="list-style-type: none"> <li>NA</li> </ul>	<ul style="list-style-type: none"> <li>Excellent.</li> </ul>
Acceptability	<ul style="list-style-type: none"> <li>May be unsightly. Use of solvents near streams undesirable.</li> </ul>	<ul style="list-style-type: none"> <li>NA</li> </ul>	<ul style="list-style-type: none"> <li>Excellent</li> </ul>
Constructability	<ul style="list-style-type: none"> <li>NA</li> </ul>	<ul style="list-style-type: none"> <li>NA</li> </ul>	<ul style="list-style-type: none"> <li>Most feasible as a coating on components for new structure.</li> </ul>
Compliance with Regulations	<ul style="list-style-type: none"> <li>NA</li> </ul>	<ul style="list-style-type: none"> <li>NA</li> </ul>	<ul style="list-style-type: none"> <li>Inert and non-toxic once cured.</li> </ul>
Compliance with Environmental Requirements	<ul style="list-style-type: none"> <li>NA</li> </ul>	<ul style="list-style-type: none"> <li>NA</li> </ul>	<ul style="list-style-type: none"> <li>Inert and non-toxic once cured.</li> </ul>
Other?	<ul style="list-style-type: none"> <li>NA</li> </ul>	<ul style="list-style-type: none"> <li>NA</li> </ul>	<ul style="list-style-type: none"> <li>NA</li> </ul>
Summary			
Advantages	<ul style="list-style-type: none"> <li>NA</li> </ul>	<ul style="list-style-type: none"> <li>NA</li> </ul>	<ul style="list-style-type: none"> <li>Could facilitate temporary removal of nests.</li> </ul>
Disadvantages	<ul style="list-style-type: none"> <li>NA</li> </ul>	<ul style="list-style-type: none"> <li>NA</li> </ul>	<ul style="list-style-type: none"> <li>May deter nests from sticking to surface even during non-maintenance years</li> <li>Ease of temporarily removal likely does not warrant expense.</li> </ul>

**Table 4c. Evaluation Criteria for Temporary Swallow Nesting Solutions - Other.**

<b>Product</b>	<b>APHIS-WR</b>	<b>Bridge Redesign</b>
Source and Discussion	<ul style="list-style-type: none"> <li>• The US Department of Agriculture, Animal and Plant Health Inspection Service (APHIS), Wildlife Services group in Colorado can be contacted as follows:               <ul style="list-style-type: none"> <li>• Colorado Wildlife Services State Director, 12345 West Alameda Parkway, Suite 204, Lakewood, CO 80228</li> <li>• 303 236 5810 (phone), 303 236 5821 (fax)</li> <li>• <a href="http://www.aphis.usda.gov/wildlife_damage/colorado_info.shtml">http://www.aphis.usda.gov/wildlife_damage/colorado_info.shtml</a></li> </ul> </li> <li>• Establishment of a cooperative agreement between a DOT and APHIS has been done successfully in Oregon and likely other states. APHIS manages swallows at Oregon bridges as needed and similar services should be available for swallows in Colorado. In the Oregon situation, APHIS charges ODOT for actual time and materials expended by its personnel; no profit is paid because APHIS is a government agency.</li> <li>• CDOT could establish a similar cooperative agreement with APHIS-WS in Colorado.</li> <li>• Ultimately, using the services of APHIS-WS may be more cost effective than the hiring of subcontractors to install deterrents, since the subcontractors hope to make a profit. The success of this approach would depend on the timely availability of APHIS-WS personnel and the cost of their salaries relative to those of subcontractors.</li> <li>• Another advantage of using APHIS-WS to control swallows is that, if there were inadvertent or unavoidable "take" of swallows on a project where APHIS-WS is responsible for species control, they should already have appropriate permits for this to be legal.</li> <li>• Selection and installation/maintenance of roosting/nesting deterrent</li> </ul>	<ul style="list-style-type: none"> <li>• Bridge redesign is discussed in the text of the Interim Report under Tasks V and VI.</li> <li>• For the most part, redesign is an inappropriate consideration for swallows, because deterrents to their nesting are to be used only temporarily.</li> <li>• However, it might be appropriate to install permanent fixtures in new structures so that the temporary deterrents could be rapidly installed when needed.</li> </ul>

Product	APHIS-WR	Bridge Redesign
	<p>devices by CDOT personnel would likely be the most cost effective solution in the long run. The success of this approach would depend on:</p> <ul style="list-style-type: none"> <li>○ Developing and following a specified protocol for timely identification of structures needing temporary swallow nesting deterrents prior to an upcoming nesting season, and then installing, monitoring, and maintaining these deterrents so long as they are needed, plus removing them when they are no longer necessary.</li> <li>○ Establishing a proactive rather than reactive group within the maintenance division that is responsible for regular installation, monitoring, maintenance, and removal of temporary swallow nesting deterrents.</li> <li>● The tabular topics below are not relevant to an effective consideration of a cooperative agreement between CDOT and APHIS-WS in Colorado.</li> </ul>	

**Table 4d. Evaluation Criteria for Temporary Swallow Nesting Solutions – Netting/Curtain.**

Product	Netting	Curtain
Source	<ul style="list-style-type: none"> <li>• Nixalite, Inc. and others</li> </ul>	<ul style="list-style-type: none"> <li>• FMH Material Handling Solutions (<a href="http://www.theonlinecatalog.com/fmhsolutions/store/search.asp">http://www.theonlinecatalog.com/fmhsolutions/store/search.asp</a>)</li> </ul>
Effectiveness in Discouraging		
Nesting	<ul style="list-style-type: none"> <li>• Netting is highly effective in discouraging swallow nesting if it is carefully installed so that there are no openings for the birds to slip through and the netting is taut to prevent the birds from becoming tangled in it.</li> <li>• This is the approach CDOT used currently to temporarily deter swallows from nesting.</li> </ul>	<ul style="list-style-type: none"> <li>• Curtains are effective in precluding nesting, although specific studies documenting the extent of their effectiveness were not found.</li> </ul>
Ease of Providing Needed Bridge Access	<ul style="list-style-type: none"> <li>• Installation of netting is very labor intensive.</li> <li>• Installing netting beneath high bridges can be difficult.</li> <li>• Netting installation works best in CBCs, but in these, the netting must come all the way to the surface of the water to prevent birds from flying beneath it to enter the CBC.</li> </ul>	<ul style="list-style-type: none"> <li>• Curtains attachment could require access to the entire length of the angle at the top of a CBC call or bridge abutment if individual strips are used.</li> <li>• If plastic curtains are used, it might be possible to permanently install a track or pipe beneath a bridge or CBC and, when needed, install the curtain from one side of the bridge using a pulley system.</li> <li>• If metal panels are used, hooks for the panels could be permanently installed, and the panels hung when needed.</li> </ul>
Negative Impacts/Risks		
Humans	<ul style="list-style-type: none"> <li>• None, although netting can be less than aesthetic if it</li> </ul>	<ul style="list-style-type: none"> <li>• None.</li> </ul>

Product	Netting	Curtain
	is visible to the public.	
Birds	<ul style="list-style-type: none"> <li>• None, if the netting is properly installed and maintained.</li> <li>• Netting that is loose or has dangling threads, etc. can entrap birds and result in mortality.</li> </ul>	<ul style="list-style-type: none"> <li>• None. Birds could still fly through the CBC or beneath a bridge, using the area for feeding.</li> </ul>
Environment	<ul style="list-style-type: none"> <li>• None.</li> </ul>	<ul style="list-style-type: none"> <li>• None.</li> </ul>
Infrastructure	<ul style="list-style-type: none"> <li>• None.</li> </ul>	<ul style="list-style-type: none"> <li>• None.</li> </ul>
Cost		
Initial	<ul style="list-style-type: none"> <li>• 50x100 ft KH net=\$1,750.00</li> <li>• 250 ft cable=\$40.95</li> <li>• turnbuckles ((10))=\$178.70</li> <li>• misc. hardware (thimbles, clamps, d rings, screw eyes, eyebolts, etc.)=\$500.00</li> <li>• Pneumatic ring tool=\$497.35</li> </ul>	<ul style="list-style-type: none"> <li>• Curtains can be made from a variety of materials. Materials considered include strip door strips, plastic curtains, and smooth coated metal panels.</li> <li>• A 3' wide by 7' high strip door=\$62.73; custom sizes are available and a quote needs to be requested.</li> <li>• Universal strip door hardware comes in 2 to 10' lengths at a cost between \$11.41 and \$57.16 per strip.</li> <li>• Door strip material is also available in uncut 150-300' rolls of varying thickness (.16-.08 mils, respectively) at a cost between \$367.50 and \$183.00, respectively.</li> <li>• Instant welding curtains (14 mil transparent vinyl material with grommets every 12" in gray, orange, or yellow and rolls 64" by 25 yards long)=\$262.50/roll. if each roll were</li> </ul>

Product	Netting	Curtain
		<p>cut in half across its width, 50 yards of 32" curtain would be available.</p> <ul style="list-style-type: none"> <li>• Curtain hooks for 1" pipe=\$3.00 per package of 10.</li> </ul>
Maintenance	<ul style="list-style-type: none"> <li>• Minimal since this would not be a permanent installation.</li> </ul>	<ul style="list-style-type: none"> <li>• Minimal since this would not be a permanent installation.</li> </ul>
Replacement	<ul style="list-style-type: none"> <li>• Because swallows are a protected species, netting must be kept in good repair without holes or dangling threads.</li> <li>• Replacement costs would be the same as initial purchase costs since net repair would be labor intensive and too costly.</li> </ul>	<ul style="list-style-type: none"> <li>• Minimal if materials are carefully stored.</li> <li>• However, the success of this method rests on the presence of a slick surface that nest mud cannot adhere to. Thus, if the plastic becomes creased or the metal dimpled or bent, a foothold for the nest mud could be established.</li> </ul>
Service Life	<ul style="list-style-type: none"> <li>• Materials used are expendable. Would need to be replaced if damaged.</li> </ul>	<ul style="list-style-type: none"> <li>• Materials used are expendable. Would need to be replaced if damaged.</li> </ul>
Life-cycle	<ul style="list-style-type: none"> <li>• If netting is installed and taken down carefully, it should last for a number of years.</li> </ul>	<ul style="list-style-type: none"> <li>• Mounting system could be permanently installed and left at bridge or CBC.</li> <li>• Curtain material might need to be replaced after several uses.</li> </ul>
Effectiveness	<ul style="list-style-type: none"> <li>• Netting and its installation materials are relatively inexpensive. Cost effectiveness is markedly lowered, however, by the labor needed to properly install it and ensure that it remains in good repair.</li> </ul>	<ul style="list-style-type: none"> <li>• Materials are relatively inexpensive. If mounting systems were left in place, subsequent use of a curtain system at a bridge would be very cost effective.</li> </ul>
Installation		
Method	<ul style="list-style-type: none"> <li>• Excellent detailed instructions on netting installation</li> </ul>	<ul style="list-style-type: none"> <li>• Recommendations are to install a</li> </ul>



Product	Netting	Curtain
	<p>are available at:  <a href="http://www.nixalite.com/installbirdnetting.aspx">http://www.nixalite.com/installbirdnetting.aspx</a> and at links from that web page.</p> <ul style="list-style-type: none"> <li>• Information is given on how to install a cable support system, how to overlap seams to make a net larger, how to fit a net around obstructions, and how to fasten the perimeter of the net and support it internally.</li> <li>• Support cables are recommended every 25' unless there are sufficient overhead support to tie to frequently.</li> </ul>	<p>curtain at least 18 inches long about 4 inches out from the vertical CBC wall or bridge abutment.</p> <ul style="list-style-type: none"> <li>• At the ends of the curtain, it would need to be tied to the wall or abutment.</li> <li>• The 4 inch space behind the curtain is too narrow for the swallows to fly into, and the flexible/slippy material won't allow nest mud to adhere.</li> <li>• Strip doors have special hardware strips on which the plastic door strips hang.</li> <li>• The vinyl curtain with grommets is designed to be hung from a track or pipe.</li> <li>• An AeroKret or Teflon coated metal sheet could be hung from hooks.</li> <li>• Care must be taken to prevent the mounting system from becoming an anchor for the first mouthful of nest mud. If a foothold for a small bit of mud can be found, other mud can stick to the first bit and the nest structure can start to grow.</li> </ul>
Frequency	<ul style="list-style-type: none"> <li>• As needed. Minor repair of holes and snags may be possible while the net is in place.</li> <li>• If the net must be taken down for repair, it may be most cost effective to simply replace it.</li> </ul>	<ul style="list-style-type: none"> <li>• As needed. Once established the curtain system should be in place throughout the nesting season. Depending on the material used, it might need to be removed during the winter to prevent unnecessary wear</li> </ul>

<b>Product</b>	<b>Netting</b>	<b>Curtain</b>
		and tear.
Ease	<ul style="list-style-type: none"> <li>• Labor intensive since the netting must be fastened so that it has no gaps, tears, wrinkles or excessive sag.</li> <li>• Installation can be difficult beneath tall bridges or where water flows right up to a bridge abutment. Because the net lacks structure, it must be carried between fastening points and handled carefully.</li> </ul>	<ul style="list-style-type: none"> <li>• Easy to install once the mounting system is in place.</li> </ul>
Maintenance		
Requirements	<ul style="list-style-type: none"> <li>• Minimal because this is a temporary deterrent.</li> <li>• However, because of the potential for swallows becoming trapped in the netting, it should be checked frequently to be sure it is taut and safe.</li> </ul>	<ul style="list-style-type: none"> <li>• Minimal because this is a temporary deterrent.</li> <li>• However, it would be wise to regularly check each structure fitted with a temporary deterrent until sufficient data were collected to establish confidence that swallow nests were 100% deterred.</li> </ul>
Cost	<ul style="list-style-type: none"> <li>• Minor repairs can be made in situ by hand. If the net must be taken down to repair it, replacement may be more cost effective.</li> </ul>	<ul style="list-style-type: none"> <li>• Minimal.</li> </ul>
Ease	<ul style="list-style-type: none"> <li>• Minor repairs are easily done but more substantial repairs can be labor intensive.</li> </ul>	<ul style="list-style-type: none"> <li>• Easily done.</li> </ul>
Availability	<ul style="list-style-type: none"> <li>• Readily available.</li> </ul>	<ul style="list-style-type: none"> <li>• Readily available.</li> </ul>
Technology		
Public Acceptance	<ul style="list-style-type: none"> <li>• High.</li> </ul>	<ul style="list-style-type: none"> <li>• High.</li> </ul>
Acceptability	<ul style="list-style-type: none"> <li>• High.</li> </ul>	<ul style="list-style-type: none"> <li>• High.</li> </ul>
Constructability	<ul style="list-style-type: none"> <li>• Readily shaped to fit diverse sites.</li> </ul>	<ul style="list-style-type: none"> <li>• Readily developed.</li> </ul>
Compliance with Regulations	<ul style="list-style-type: none"> <li>• Yes.</li> </ul>	<ul style="list-style-type: none"> <li>• Yes.</li> </ul>
Compliance with Environmental	<ul style="list-style-type: none"> <li>• Yes.</li> </ul>	<ul style="list-style-type: none"> <li>• Yes.</li> </ul>

<b>Product</b>	<b>Netting</b>	<b>Curtain</b>
Requirements		
Other?	<ul style="list-style-type: none"> <li>• NA</li> </ul>	<ul style="list-style-type: none"> <li>• NA</li> </ul>
Summary		
Advantages	<ul style="list-style-type: none"> <li>• Netting and its installation materials are relatively inexpensive.</li> <li>• Netting can be shaped to work in nearly all situations.</li> <li>• When properly installed, netting is highly effective as a deterrent to nesting.</li> </ul>	<ul style="list-style-type: none"> <li>• Effective.</li> <li>• Relatively inexpensive.</li> <li>• Potential for permanent mounting system with replaceable curtain attached as needed.</li> <li>• May be possible to install curtain from one side of even high structures once mounting system is in place.</li> </ul>
Disadvantages	<ul style="list-style-type: none"> <li>• Installation is labor intensive and may be difficult in some situations.</li> <li>• Because the net is made of fabric, it needs to be replaced more frequently than deterrents made of metal or other more stable materials.</li> <li>• If not properly installed and maintained, netting can cause mortality in birds and other species. This is a particular problem when dealing with protected species such as swallows.</li> <li>• Use of netting blocks the entire section of stream within a CBC or beneath a bridge from use by foraging swallows—they cannot feed there or use it as part of their foraging routes.</li> </ul>	<ul style="list-style-type: none"> <li>• Potential for mud to be stuck to flaws in the curtain or to the mounting system.</li> </ul>

**Table 4e. Evaluation Criteria for Temporary Swallow Nesting Solutions – Corner Slope/Spikes.**

<b>Product</b>	<b>Corner Slope</b>	<b>Spikes</b>
Source	<ul style="list-style-type: none"> <li>• Ultimate Bird Control LLC. (866-482-4737) for Bird Slide, a plastic corner slope.</li> <li>• A homemade version of the corner slope made with a flexible piece of fiberglass or plastic can also be used. Dipcraft Manufacturing Company (<a href="http://www.dipcraft.com/pricing.html">http://www.dipcraft.com/pricing.html</a>) carries fiberglass panels.</li> </ul>	<ul style="list-style-type: none"> <li>• Nixalite, Inc., and others</li> </ul>
Effectiveness in Discouraging		
Nesting	<ul style="list-style-type: none"> <li>• Highly effective in deterring swallow nesting.</li> </ul>	<ul style="list-style-type: none"> <li>• Will generally preclude nesting, although, it is possible for mud to adhere to spikes.</li> <li>• Special prescription for application of spikes to deter swallow nesting.</li> <li>• Very effective when properly applied and maintained.</li> </ul>
Ease of Providing Needed Bridge Access	<ul style="list-style-type: none"> <li>• Bird Slide is installed on a clean surface with silicone adhesive. Therefore access to the CBC or bridge must be sufficient to clean the surface and place 4' lengths of the Bird Slide Material. If there are protrusions from the horizontal surface to be protected, careful measurements must be taken so the Bird Slide can be cut to fit around the protrusions.</li> <li>• Fiberglass panels could be installed in permanently attached angle iron. CBC and bridge ceilings, walls, and abutments would need to be accessed for the initial installation of the angle iron.</li> </ul>	<ul style="list-style-type: none"> <li>• Strips of spikes must be screwed into surface, requiring access to almost the entire length of surface to be protected.</li> </ul>
Negative Impacts/Risks		
Humans	<ul style="list-style-type: none"> <li>• None</li> </ul>	<ul style="list-style-type: none"> <li>• None</li> </ul>

<b>Product</b>	<b>Corner Slope</b>	<b>Spikes</b>
Birds	<ul style="list-style-type: none"> <li>• None</li> </ul>	<ul style="list-style-type: none"> <li>• None</li> </ul>
Environment	<ul style="list-style-type: none"> <li>• None</li> </ul>	<ul style="list-style-type: none"> <li>• None</li> </ul>
Infrastructure	<ul style="list-style-type: none"> <li>• None</li> </ul>	<ul style="list-style-type: none"> <li>• None</li> </ul>
Cost		
Initial	<ul style="list-style-type: none"> <li>• Costs and available dealers can be found by calling 1-866-482-4737</li> <li>• Dipcraft Manufacturing Company will provide quotes for specific orders: 111 West Braddock Avenue Braddock, PA 15104 412-351-2363 800-245-6145 Fax: 412-351-4528</li> </ul>	<ul style="list-style-type: none"> <li>• 4 inch Model S spikes to mount on ceiling at top of upper corner with CBC wall or bridge abutment</li> <li>• 4 inch Model W spikes mounted to CBC wall or bridge abutment directly below each Model S cluster=\$518.00</li> <li>• Available in 2 ft and 4 ft lengths</li> <li>• 100 ft kit=\$518.00</li> </ul>
Maintenance	<ul style="list-style-type: none"> <li>• Minimal maintenance cost. Bird Slide can be painted, so the cost of periodic painting could be figured in, although the painting is primarily for aesthetic reasons.</li> <li>• Maintenance unlikely to be needed for temporary installation.</li> </ul>	<ul style="list-style-type: none"> <li>• Minimal cost if done consistently.</li> <li>• Maintenance unlikely to be needed for temporary installation.</li> </ul>
Replacement	<ul style="list-style-type: none"> <li>• Same an initial investment.</li> </ul>	<ul style="list-style-type: none"> <li>• Spikes are made of stainless steel and if properly installed and maintained should last for many years without replacement.</li> </ul>
Service Life	<ul style="list-style-type: none"> <li>• No repair likely except for silicone fill of minor gouges.</li> </ul>	<ul style="list-style-type: none"> <li>• Unknown</li> </ul>
Life-cycle	<ul style="list-style-type: none"> <li>• Bird-Slide touted to provide "years of 'bird-free' protection."</li> <li>• Fiberglass panels should be readily stored and reused for many years</li> </ul>	<ul style="list-style-type: none"> <li>• Unknown</li> </ul>

Product	Corner Slope	Spikes
Effectiveness	<ul style="list-style-type: none"> <li>• Good longevity and effectiveness with minimum need for repair if properly installed.</li> <li>• Cost effectiveness reduced by if special fitting around protrusions requires extensive labor.</li> </ul>	<ul style="list-style-type: none"> <li>• Highly effective if properly installed and maintained.</li> </ul>
<b>Installation</b>		
Method	<ul style="list-style-type: none"> <li>• Bird Slide comes in 4' lengths and will fit effectively on horizontal surfaces up to 5 and 7/8 inches wide. The product can be bonded and stacked with a second slide for use on wider surfaces.</li> <li>• Narrow surfaces may require the Bird Slide trim area to be cut—the goal is for the "slide"—the hypotenuse of the triangle to be just long enough that the horizontal leg of the triangle covers the entire horizontal surface to be protected..</li> <li>• Adhesive silicone #2 is applied in holes drilled every 12" in the slide and as a bead the full length of the slide.</li> <li>• Fiberglass panels are available in 4-12 oz weights. Smooth and translucent panels are 4' and 5' wide and of any length; Smooth and opaque panels are 4' wide and 8'-12' long.</li> <li>• Permanent positioning of an angle iron with a lip on the ceiling and on the wall or abutment would allow the fiberglass panels to be "popped" into place by flexing them. They could be readily removed and stored when the reconstruction was completed.</li> </ul>	<ul style="list-style-type: none"> <li>• Screwed into surface to be protected at strictly specified distances.</li> <li>• Minimum of 1/4" wire overhang and 1/2" base strip overhang are required.</li> <li>• Effective installation requires at least one row of Model S and at least one row of Model W spikes.</li> <li>• Each row of spikes must run the entire length of the location to be protected.</li> <li>• Excellent installation instructions are available at: <a href="http://www.nixalite.com/PDFs/mudswallow.pdf">http://www.nixalite.com/PDFs/mudswallow.pdf</a></li> </ul>
Frequency	<ul style="list-style-type: none"> <li>• The angle iron should last for many years.</li> </ul>	<ul style="list-style-type: none"> <li>• Infrequent, as product has longevity (if stainless steel rather than plastic spikes are used)</li> </ul>
Ease	<ul style="list-style-type: none"> <li>• Very easy to install. If Bird Slide and adhesive are used, they are easy to install but somewhat more</li> </ul>	<ul style="list-style-type: none"> <li>• Easy but labor intensive and access to length of surface to be protected is</li> </ul>

<b>Product</b>	<b>Corner Slope</b>	<b>Spikes</b>
	<p>difficult to remove.</p> <ul style="list-style-type: none"> <li>If fiberglass panels are used, installing the angle iron would be more labor intensive, but the panels could be readily placed and removed thereafter, as needed.</li> </ul>	<p>required.</p> <ul style="list-style-type: none"> <li>Longevity of product is actually a detriment in the case of swallows, since the carefully measured and installed product would need to be removed once the reconstruction project was completed.</li> </ul>
Maintenance		
Requirements	<ul style="list-style-type: none"> <li>Panels would eventually lose their flexibility due to UV exposure and would need to be replaced.</li> </ul>	<ul style="list-style-type: none"> <li>None required since spikes would be removed at the end of the reconstruction project.</li> </ul>
Cost	<ul style="list-style-type: none"> <li>Same as initial investment for Bird Slide and fiberglass panels</li> </ul>	<ul style="list-style-type: none"> <li>NA</li> </ul>
Ease	<ul style="list-style-type: none"> <li>Little maintenance required except for occasional panel replacement.</li> </ul>	<ul style="list-style-type: none"> <li>NA</li> </ul>
Availability	<ul style="list-style-type: none"> <li>Readily available.</li> </ul>	<ul style="list-style-type: none"> <li>Readily available.</li> </ul>
Technology		
Public Acceptance	<ul style="list-style-type: none"> <li>High</li> </ul>	<ul style="list-style-type: none"> <li>High</li> </ul>
Acceptability	<ul style="list-style-type: none"> <li>High</li> </ul>	<ul style="list-style-type: none"> <li>High</li> </ul>
Constructability	<ul style="list-style-type: none"> <li>High</li> </ul>	<ul style="list-style-type: none"> <li>High</li> </ul>
Compliance with Regulations	<ul style="list-style-type: none"> <li>High</li> </ul>	<ul style="list-style-type: none"> <li>High</li> </ul>
Compliance with Environmental Requirements	<ul style="list-style-type: none"> <li>High</li> </ul>	<ul style="list-style-type: none"> <li>High</li> </ul>
Other?	<ul style="list-style-type: none"> <li>NA</li> </ul>	<ul style="list-style-type: none"> <li>NA</li> </ul>
Summary		
Advantages	<ul style="list-style-type: none"> <li>Highly effective at deterring nesting.</li> <li>Aesthetic installation</li> <li>Easy installation of Bird Slide.</li> </ul>	<ul style="list-style-type: none"> <li>Quality product that is highly acceptable and compliant.</li> </ul>

<b>Product</b>	<b>Corner Slope</b>	<b>Spikes</b>
	<ul style="list-style-type: none"> <li>• Easy set up and take down of fiberglass panels once angle iron is in place.</li> <li>• Fiber glass panels are relatively inexpensive and readily stored.</li> </ul>	
Disadvantages	<ul style="list-style-type: none"> <li>• Bird Slide removal would take work to break the adhesive free. If the adhesive has aged a bit and is inflexible, the Bird Slide could be broken when removed.</li> <li>• Installation of the angle iron may be labor intensive, depending on the weight and material used and whether there are protrusions that must be worked around.</li> </ul>	<ul style="list-style-type: none"> <li>• Tedious installation and long term solution may be overkill because of temporary nature of deterrent need.</li> <li>• While precise specifications for spike installation for swallows have been developed, documentation of successful installation was not found.</li> <li>• Swallows have been documented learning to land on the spikes and eventually building a nest on them. Thus, this is not a widely used method to deter swallow nesting.</li> </ul>



**Table 4f. Evaluation Criteria for Temporary Swallow Nesting Solutions – Nest Removal.**

<b>Product</b>	<b>Nest Removal</b>
Source and Discussion	<ul style="list-style-type: none"> <li>• The presence of old nest mud on a CBC wall or bridge abutment is a strong psychological attractant to swallows returning to a prior nesting location or looking for a new place place to build.</li> <li>• Further, the presence of old mud gives the swallows a place to start attaching fresh mud to build a new nest.</li> <li>• Therefore, as part of all deterrent methods, all old swallow nesting mud should be removed before installing the deterrent. Nest mud can be removed with a long handled ice scraper. Use of water, (or other solvent, if needed for bonding) and a brush, or pressure washing should not be necessary except in locations where the attachment of a deterrent requires a clean and dry surface.</li> <li>• See also the discussion under AeroKret, a surface coating.</li> <li>• Removing nest mud, in and of itself, will not deter swallows from building in a location.</li> <li>• Therefore, nest removal is not discussed further.</li> </ul>

### **1.2.1 Additional Comments on Permanent Pigeon Roosting/Nesting Deterrents**

Ultimately, the most effective methods to deter pigeon roosting/nesting are either physical deterrents (i.e., spikes, wires, corner slope, and netting), or non-toxic chemical methods (i.e., methyl anthranilate). For any of these methods, proper installation and maintenance are keys to their success. The most appropriate of these methods depends on the configuration of the specific site, the extent of the problem, and the cost-effectiveness of the method relative to the extent of the problem. The fact that pigeon installations are to be permanent must be a consideration in evaluating the method's cost effectiveness. The methods recommended as most effective deterrents for pigeon roosting/nesting are spikes, wires, and the commercial Bird Slide product. Methyl anthranilate may be especially useful at sites that have relatively confined spaces and are heavily used by pigeons (e.g., the Broadway overpass of Hampden). Application of a protective surface coating such as AeroKret to facilitate cleanup of sites from which pigeons cannot reasonably be excluded should also be considered. Eight sample panels coated with varying thicknesses of AeroKret were donated to this project by Analytical Services & Materials, Inc. (Dr. R. Sivakumar, 107 Research Dr., Hampton, VA 23666, 757-865-7093 ext. 304, [www.asm-usa.com](http://www.asm-usa.com)) and are intended to be affixed to surfaces heavily used by pigeons by CDOT staff when they are working in such areas for other reasons. Finally, the ultimate answer for deterrence of pigeon roosting/nesting is design change that will eliminate or make inaccessible the horizontal surfaces favored by pigeons.

### **1.2.2 Additional Comments on Temporary Migratory Bird Nesting Deterrents**

Ultimately, the most effective methods to be used to deter swallow nesting are also either physical deterrents or non-toxic chemical methods. The above comments on proper installation/maintenance and on site-specific conditions are important here as well. The methods recommended as most effective deterrents for swallow nesting are the corner slope, curtains, and netting. Methyl anthranilate may also be effective in CBCs because they are somewhat confined spaces. It was considered inappropriate to use in the field test of swallow deterrents because methyl anthranilate must be applied with equipment that was too costly to be included in this study and further because it would have been necessary to obtain US Fish and Wildlife Service (USFWS) concurrence that this chemical would in no way harm these protected species. Equipment cost, the need to coordinate use of this chemical with the, USFWS, and the necessity of having a power source must be kept in mind when planning to use methyl anthranilate.

## **1.3 Investigate Other Options to Minimize CDOT Personnel Exposure**

### **1.3.1 Consultation with Study Panel**

Consultation with the Study Panel was initiated at the first Study Panel Meeting on October 2, 2007. The Agenda for this meeting, the PowerPoint presentation provided at the meeting, and the notes summarizing the results of this meeting were included on the CD submitted with the Interim Report. The most important aspects of this meeting were discussion of the shared vision for this study, and clarification that the field study was intended only to test temporary deterrents to swallow nesting.

Study Panel meetings were also held on February 12, 2008 and on August 25, 2008. At the February meeting, information in the Interim Report was presented and discussed, and plans for field testing of temporary swallow nesting deterrents were presented, discussed, and further developed. At the August meeting, results of the field testing program were presented and next steps in this project were discussed and decided upon. Additional information on the field testing is provided below.

In addition, consultation with individual Study Panel members was conducted via email and telephone throughout the project. Their contributions are incorporated throughout this document.

### **1.3.2 Field Visit**

After the first Study Panel Meeting, a field visit was conducted on November 1, 2007. People attending the field visit were: Patricia Martinek, Debra Angulski, Jim Eussen, Jane Hann, and Jeff Peterson. Stops were made at several bridge, culvert, and overpass locations; the goal being to see good examples of problem nesting/roosting, and discuss the details of how the existing nesting/roosting causes problems for inspection and maintenance personnel. Stops were made at several concrete box culverts (CBCs; Mile marker 191 on I25, near the CDOT facility on W. Stene Drive just off W470 near Wadsworth Boulevard, and US36 and Storage Tek Drive), at a bridge where Broadway crosses Hampden, and at overpasses where I70 crosses I25. At each location and during transit, discussion and brainstorming occurred among trip attendees as to how representative each location was of nesting/roosting problems, each location's appropriateness as a test site, and what type of deterrent might be most effective at each location. Discussion of the problems encountered by engineering, inspection, and maintenance crews was limited, as no personnel from these groups attended the field visit. During the field visit, it was decided that the best location to perform swallow field tests would be the CBCs near Storage Tek Drive. However, it was noted that these may not be owned by CDOT and, if this is so, their use would require permission from their owner. It was also decided that having a second test site that was a bridge used by both cliff and barn swallows would be desirable and CDOT Study Panel members agreed to try and find such a bridge.

After subsequent communication via email, it was determined that a CDOT access permit is necessary to work on CBCs owned by CDOT. These permits are issued by the regions (Region 1: Anna Welch at 303-365-7305; Region 4: Chris Kelly at 303-546-5643; and Region 6: Mike Smith at 303-365-7305). Chris Kelly worked to determine who owns the Storage Tek Drive CBCs and who should be contacted regarding their use. He determined that these CBCs belong to the City and County of Broomfield and gave me contact information for Geoff Wells (Street Operations Superintendent, City & County of Broomfield, 303-464-5694), who turned this project over to Ron Jones (Streets Foreman, City & County of Broomfield, 303-464-5658). After visiting the site, Ron Jones approved our use of the Broomfield CBCs, with the caveat that most materials, especially metal pieces with sharp edges, should be removed at the end of the study.

Possible bridge locations were sought by Jeff Peterson and Jim Eussen. Both found bridges that had cliff and barn swallows using them, but these bridges did not appear useable because they were too high or had current or projected water flows from abutment to abutment. Therefore, it was decided that field tests would be conducted only in CBCs, with several methods and a control distributed among the CBCs.

### **1.3.3 Risks to Human Health and Safety**

Birds, including pigeons and swallows, have diseases, internal parasites, and ectoparasites. Some of these diseases and parasites can infect humans, but most are unlikely to do so. Further, if humans are infected, it is likely to be only temporarily. This is because most diseases and parasites have adapted to their normal host's physiology. Birds have a higher body temperature (103-108°F) than humans (98.6°F). This is significant in physiological terms and makes humans an unlikely long term host for avian parasites.

Long lists of diseases associated with birds tend to be provided on web sites that also sell products to deter birds from roosting or nesting. However, based on an article on avian diseases transmissible to humans prepared by the University of Florida for bird keepers<sup>1</sup>, the most likely diseases that can be contracted by humans from birds are the following:

- ornithosis—caused by a bacteria-like organism that may be inhaled with fecal dust or ingested with feces or saliva from birds or humans, causing a feverish respiratory disease that can be serious in humans if complications in the spleen or heart occur;
- salmonellosis—caused by numerous species of Salmonella bacteria that can cause infections when feces are ingested by most animals, including humans who may have diarrhea, vomiting and low grade fever or more progressive symptoms leading to serious illness, especially if they are very young or old;
- colibacillosis—caused by bacteria that inhabit the intestinal tract of all animals, including humans but which may cause diarrhea and potentially other complications when ingested;
- avian tuberculosis—caused by bacteria that in humans can cause local wound infections;
- cryptosporidiosis—caused by protozoa and potentially causing abdominal pain, nausea, and watery diarrhea, with more severe symptoms occurring in immunocompromised people;
- allergic alveolitis—caused by acute or chronic exposure and a hypersensitive reaction to excessive quantities of avian dander, feces, or feathers that result in inflammation of the pulmonary alveoli, reduced lung capacity, and other pulmonary symptoms; and
- the fungal and viral diseases discussed below.

Histoplasmosis and cryptococcosis are naturally occurring fungi that proliferate when the soil where they occur is augmented with bird droppings. These fungi can cause

---

<sup>1</sup> Jacob, J.P., J.M. Gaskin, H.R. Wilson, and F.B. Mather. 1997. Document PS23, Animal Science Department, Florida Cooperative Extension Service, Institute of Food and Agricultural Sciences, University of Florida. (<http://edis.ifas.ufl.edu/pdf/PS/PS01900.pdf>)

pulmonary diseases in humans, particularly if their immune systems have been compromised.

Some diseases of particular concern to humans such as bird flu and west Nile virus can be contracted by both birds and humans. The bird flu virus must mutate before it can be contracted by humans. There is evidence that this has happened in some parts of the world, but the virus has not yet been found in birds in North America. Further, no human cases have yet been linked to exposure to wild birds. Close contact with infected poultry and other domestic birds remains the most important source of human infections.

Humans contract west Nile virus (and western equine encephalitis) after being bitten by a mosquito carrying the virus. The virus is carried by animals such as birds, dogs, cats, and horses. Because west Nile virus results in very high and rapid mortality in birds, they are not as likely as the other virus carriers to be bitten by a mosquito that ingests the virus and then bites a human.

The ectoparasites carried by birds (bugs, fleas, lice, mites, ticks, and other biting insects) prefer to remain on their avian hosts. However, large populations of ectoparasites may remain in nests after the young have fledged, or in roosting site debris if the birds formerly present have been removed. These ectoparasites may crawl onto nearby humans, who might be bitten by them. Other than causing short term irritation, avian parasites are unlikely to damage temporary human hosts, although unusual cases of hypersensitivity and hyperreactivity in humans have been reported.

At the end of the discussion by the University of Florida Extension Service, are the following statements:

"Bird-keepers should be aware that they can contract certain illnesses from their birds. The frequency of disease transmission from birds to humans is low, but the very young, the elderly, and those with compromised immune systems should be cautious.

Many of these diseases are transmitted by ingestion of food contaminated by fecal matter. Prevention of most of these diseases, therefore, simply involves proper hygiene and sanitation. Wearing a face mask to avoid inhaling bird dust is also recommended.

If you have persistent flu-like symptoms when no one else you know is affected, see a doctor and mention that you raise birds. Such symptoms may be indicative of a disease spread from birds to humans. "

Keep in mind that this rather mild warning is geared toward bird keepers who frequently contact birds that are kept in confined conditions. Some of the diseases discussed above are also most likely contracted by those who work in the poultry industry or avian diagnostic laboratories where exposure is more likely. Occasional contact with birds and their droppings or nest materials such as experienced by CDOT personnel is unlikely to result in disease, especially if the protective measures discussed below are followed.

#### **1.3.4 Protective Measures**

As part of this project, an information sheet to guide workers in cleaning up pigeon droppings and nest debris and recommended revisions to CDOT's Safe Operating Guide of personal protective equipment dealing with bird dropping and nesting clean-up were developed. These items are included as Appendix B and Appendix C, respectively. Individuals assigned to clean up bird droppings or nests should do the following:

- dampen the droppings and nest debris to prevent them from becoming airborne,
- wear an air purifying respirator to prevent inhalation of fungal spores that might accidentally become airborne,
- wear mosquito repellent to avoid being bitten by mosquitoes that may carry viruses obtained from biting infected birds or other animals
- remain observant and wear long sleeves and gloves, taping their junction to prevent ectoparasites from crawling onto the skin,
- avoid hand to mouth contact and eating during the cleanup job, and
- wash hands especially well, change clothes and wash clothing after completing the cleanup job.

In addition, individuals with compromised immune systems should not be assigned to clean up bird droppings or nests.

These risks to human health and safety and the recommended protective measures are summarized in an Information Sheet and in Maintenance Job Safety Analysis Form 352 to guide workers when cleaning up bird droppings and nest debris. Of all of the potential risks discussed, ectoparasites are the most likely to be encountered when cleaning swallow nests, while any of the above risks could be encountered when cleaning up pigeon droppings and nest debris. These differences are because swallows occupy their nests only seasonally and are most likely to defecate in the air since they spend considerable time in airborne pursuit of insects; droppings at the nest are almost exclusively from nestlings before they fledge. Alternatively, pigeons occupy their roosting/nesting sites year around, roost frequently during the day, and are likely to defecate most often in these sites where they spend considerable time.

### **1.4 Interviews of Bridge Personnel and Engineers Regarding Design Change Options to Prevent/Discourage Roosting/Nesting in Bridge Structures**

Communication with bridge personnel and engineers regarding relevant design change options occurred briefly during the Study Panel meetings, and via subsequent phone calls and emails. Their contributions are incorporated into the discussion that follows.

Based on discussions, observations, and understanding of pigeon behavior and habitat needs, there appear to be two types of design change options that would prevent/discourage pigeon roosting/nesting in bridge and other structures. The first is to eliminate appropriate sites for nesting/roosting by making steel and concrete "I" beam

flanges more narrow or otherwise modifying their shape so that they are inadequate for roosting and nesting. The second is to enclose structural members so that the existing flanges and platforms cannot be accessed by pigeons.

#### **1.4.1 Elimination of Appropriate Sites for Nesting/Roosting**

Pigeons tend to roost and nest on horizontal surfaces. Nests must be relatively level to keep the eggs from rolling out of the somewhat flimsy nest structure. Roosting sites that are horizontal are used most frequently, although pigeons will spend limited amounts of time on sloping or arched surfaces that are not so steep that a bird needs to flap its wings to remaining on the surface. Surfaces covered by some sort of "roof" are especially used for nesting and during inclement weather.

Such surfaces are found especially on top surfaces, decks, girders, and I beams of transportation structures. Dimensions found online for narrow, medium, and wide (light to heavy weight) I beams available in the U.S. indicate that the width of the portion of the "I" beam flange extending horizontally from the "I" beam web ranges from 19.05 to 136 mm (0.75 to 5.35 inches). Thus, steel "I" beams that have a flange sufficiently narrow to exclude pigeon use are available. Such steel "I" beams with narrow flanges should be used whenever structural adequacy and other safety considerations allow, as this would minimize the surfaces likely to be used by pigeons. However, given the structural load requirements for most CDOT construction, it is unlikely that steel I beams with flanges too narrow for pigeon roosting can be used very often, if at all.

Another option is to change the shape of horizontal steel surfaces so that their tops are at a 45 degree or greater angle. However, given the standardization, cost, and weight of steel, shaping the bottom flange of a steel "I" beam in this way when the beam is forged would be impractical. An alternative way of changing the upper slope of horizontal surfaces is to use a corner slope device (a plastic or fiberglass insert that provides a 45<sup>+</sup> degree surface that encloses the width of the flange and extends an equal distance up the web). Such a device can be added to new bridges or other structures during construction and can also be used to modify the shape of "I" beams in existing bridges. This and other such retrofitted devices are also discussed above. Input from Trevor Wang, Dick Osmun, and Jeff Anderson (see Table 2) indicates that the addition of a corner slope to steel "I" beams is the most viable solution to the pigeon problem, but that four issues need to be addressed: the longevity of the corner slope material, the weight added to the beam by the corner slope, the attachment of the corner slope to the beam, and the need to inspect the portion of the beam enclosed by the corner slope. The following bullets provide more specific considerations with regard to these issues.

- The corner slope material should last as long as the bridge structure. Metal flashing is made of a variety of materials (copper, lead-coated copper, aluminum, galvanized steel, galvalume, stainless steel, rheinzink, and lead) that vary in cost, workability, labor to install, potential for environment contamination, and longevity. Of these, stainless steel is both the most durable and among the most costly, while galvanized steel is the least durable and the least costly. The primary detriment of stainless steel is that it is difficult to shape, but since flat sheets would be used, that problem does

not apply to this application. Further information about these flashing types can be obtained online: <http://www.oldhouseweb.com/how-to-advice/roof-flashing-details.shtml>.

- Because of its durability, stainless steel flashing that is relatively thin can be used. This flashing comes in a wide range of thicknesses from 0.005" to 6" (<http://www.mcmaster.com/#type-316-stainless-steel/=agd9g>) although at some point in this range it becomes a bar rather than a sheet or strip. Type 316 stainless steel is used on Oceanside houses because lower grades cause rust stains (<http://ths.gardenweb.com/forums/load/build/msg1020133718209.html>). To reduce weight, the thinnest strip that holds up under the attachment method selected should be used.
- Attachment of the flashing to the "I" beam needs to be done in such a way that the structural integrity of the beam is not compromised, the flashing cannot be readily removed by vandals, the flashing can be readily moved aside so the beam can be inspected, and the flashing can extend beyond the edge of the flange to facilitate runoff. Flashing is available as straight strips of metal or as pre-bent counter flashing that is clipped into reglets designed for specific substrates. The straight strips of flashing could be attached to stainless steel piano hinge along their top edge. Potential types of attachment for the reglets or piano hinge include powder activated drive pins or a similar device that penetrates the beam structure, strong on/off magnets that can be attached without penetrating the beam (though they might still affect its structure through their magnetic field), and permanent adhesive. The beam could be inspected after removing the flashing (by turning off the magnets or unfastening the reglet clips) or after lifting the flashing with the piano hinge. However, it would be difficult to manage a long narrow piece of flashing to look beneath it after the magnets were turned off or the reglets unfastened. In addition, the magnets (and thus the flashing also) would be subject to vandalism. Therefore, the use of drive pins or permanent adhesive with piano hinge is the logistically preferable solution. Additional research is needed to determine the effect of drive pins or other penetrating attachments and of permanent adhesives on the structural integrity of steel "I" beams.

For concrete girders, changing the shape can be done more readily, since this simply involves modifying the shape of the forms into which the concrete is poured after the structural adequacy of the shape modification has been verified by engineering. This sort of change has been employed by CDOT.

Design changes to prevent/discourage swallow roosting/nesting in bridge structures are not desirable or requested, since swallows produce much less buildup of droppings, are native species protected by the Migratory Bird Treaty Act, and additionally are desirable because of their effective control of insect populations. For swallows, the needed deterrents to nesting are to be temporary. This is so that nesting can be precluded in any given year to enable extensive maintenance/repair/reconstruction of a structure to occur during the nesting season, yet readily removed to allow nesting to resume the following year. To facilitate the installation of such temporary deterrents, permanent fasteners to support the temporary deterrent(s) selected could be installed in all newly constructed CBCs and bridges. The design and potential usefulness of such fasteners would depend



on the temporary deterrent(s) selected. It may be possible to retrofit such fasteners into existing structures, as well.

#### 1.4.2 Preventing Access to Structural Members

Preventing access to structural members of bridges through design can be done by providing vertical structures that overlap the potential horizontal roosting/nesting sites so closely that a pigeon would not fit between them. The effectiveness of such a solution can be inferred from Figure 1<sup>2</sup>. Note that there are extensive pigeon droppings in the two side openings, but none in the two middle openings, which are narrower. Another design change option is to enclose all of the structural members in one or more polygons that have no protruding horizontal surfaces (e.g., use box girders and cover the box girder ends and access doors with screen). Such a solution is shown in Figure 2. The problem with such solutions is that any unintended or unsecured entrance to such an enclosure can enable pigeon entry with results similar to those shown in Figures 3 and 4.



**Figure 1. Pier 4 joint support beam at girder A (E16ND).**

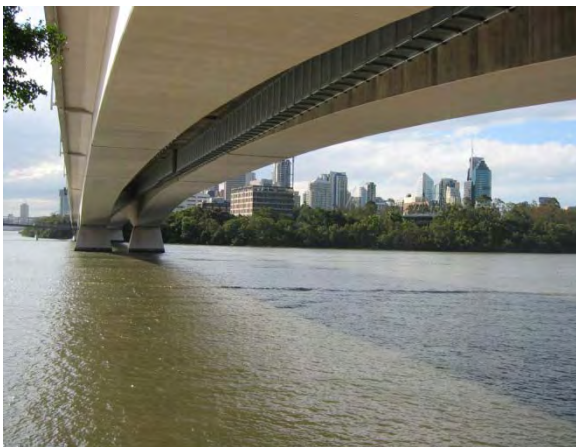

**Figure 2. Bridge in Brisbane, Australia.**

---

<sup>2</sup> Jeff Anderson, a Study Panel member, provided photos of CDOT structures where pigeon roosting/nesting was a problem



**Figure 3. 3-inch gap in splice in Gir 5A (E16ND).**



**Figure 4. Pigeon feces in Gir 5A where pigeons entered through 3-inch gap.**

For all of these approaches, implementing them at the time of bridge (or other structure) construction would be much more cost effective than retrofitting structures that are already in place. This is partially because of the efficiency of using an already mobilized construction crew and process, and partially because attachment to new structure surfaces could proceed without extensive cleaning and other preparation. To maximize cost effectiveness, it is suggested that permanent deterrents be included in the specifications for new bridges and other structures, and that the use of retrofitted deterrents be limited to specific situations where heavy pedestrian traffic or long term vehicle parking make pigeon debris of particular concern.

Finally, increased education of CDOT (and other DOT) design engineers, construction and maintenance crews is suggested to make them more aware of the problems caused by pigeon debris, the types of solutions that are most workable and available, and the results of seemingly minor errors in installation or maintenance that enable pigeon access. Such increased awareness may lead to additional ideas for effective structural deterrents, and minimize the likelihood that access doors will be left open on enclosures.

## 1.5 Describe New Bridge Design Techniques Being Employed or Proposed By CDOT

The only identified structural modification used relatively recently by CDOT to deter pigeon nesting/roosting use is the modification of concrete girders so that their bottom flange incorporates a corner slope<sup>3</sup>. This has been done on some (see Figures 5 and 6), but not all, projects in the last 10 years. A schematic drawing of the specifications for this modified concrete girder follows as Figure 7. This structural change in girder configuration has been effective in deterring pigeon roosting and nesting. However, the construction cost for non-standard forms to cast these girders, their greater weight and the consequent difficulty of handling them during construction, and need for additional support columns make these girders a less efficient transportation construct. These drawbacks may outweigh their usefulness.

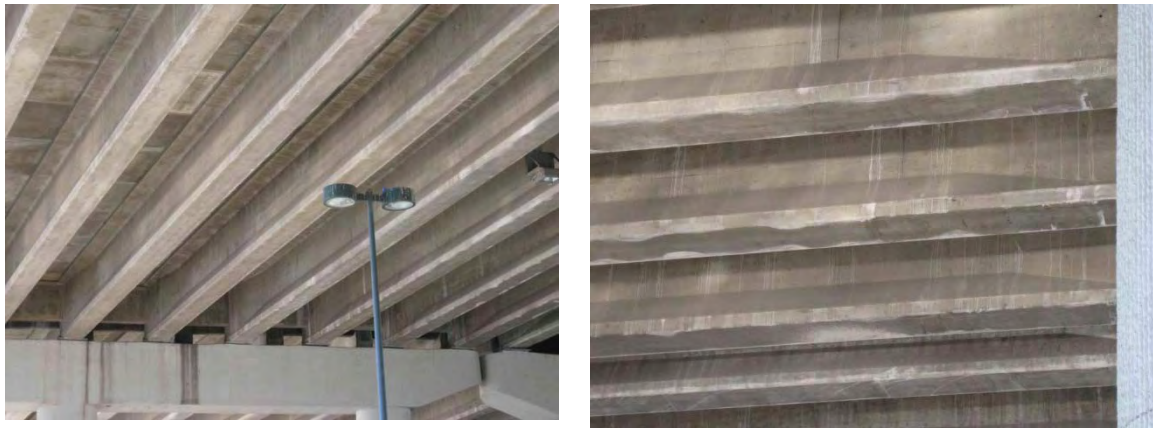



**Figures 5 and 6. The underside of I-70 in the vicinity of the Coliseum showing precast concrete girders with a built-in corner slope.**

---

<sup>3</sup> Russ Cox said that " some of the precast girder people have started casting an angle on the bottom of BT Girders so that birds cannot perch on them. This is not done by all the precast people. " Further information about modification of precast girders was provided through Debra Angulski who has an acquaintance (Jim Linskens, Quality Assurance Engineer, Rocky Mountain Pre-stress) who worked on a bridge for CDOT that contained pigeon "soffit"<sup>4</sup> elements. Jim Linskens said that about 10 years ago in CDOT Region 6, he worked on the replacement of the elevated portion of I-70 in the vicinity of the Coliseum (between I-25 and the Purina Plant). The design was proposed by George Tsiouvaras, who worked at Carter Burgess then and now works for Tsiouvaras Simmons Holderness. George Tsiouvaras provided information and the design drawing included in this discussion.

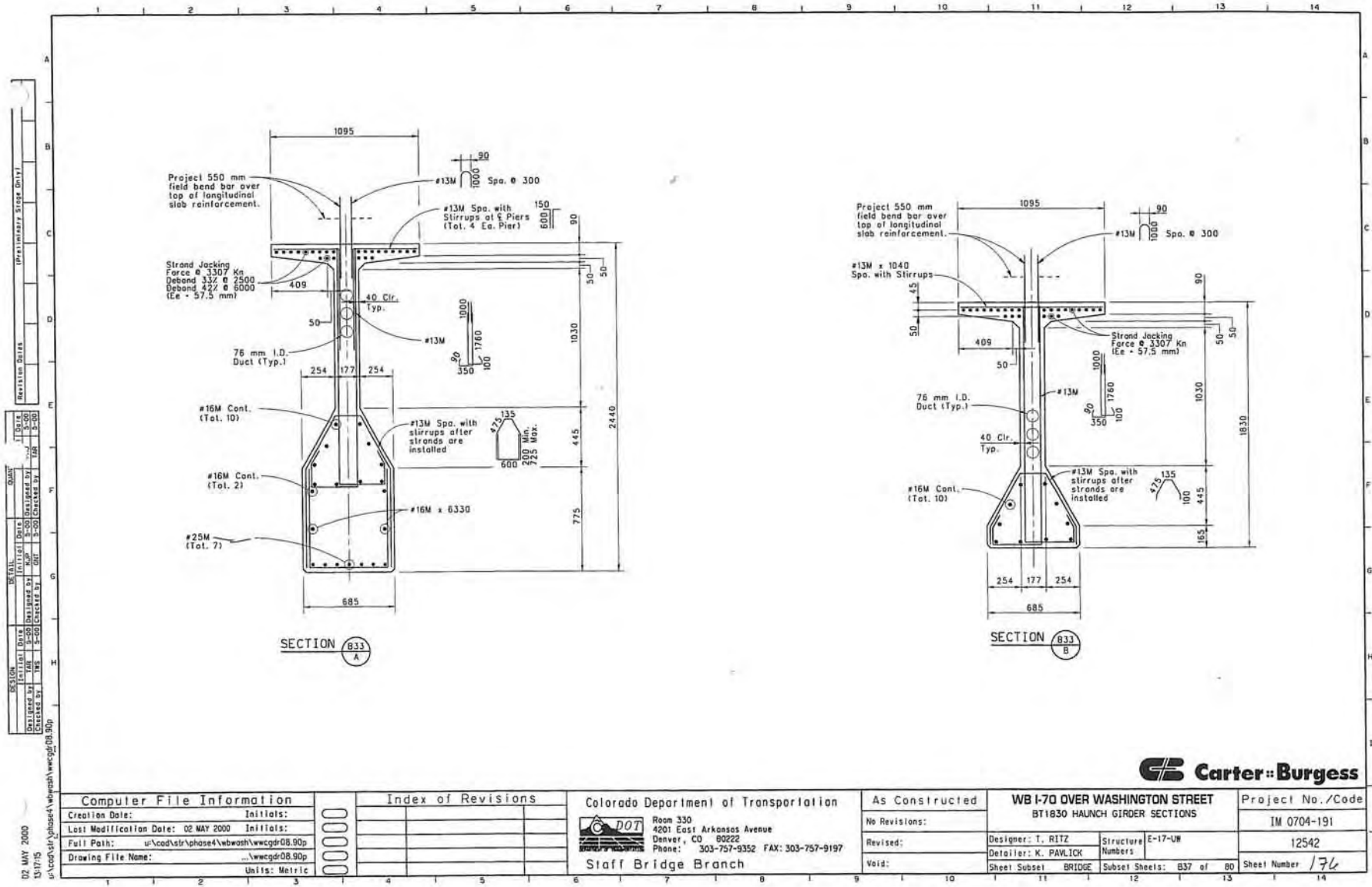
Figure 7. Schematic diagram of a precast concrete girder that incorporates a corner slope.<sup>4</sup>



<b>Computer File Information</b> Creation Date:                      Initiats:                      ○ Last Modification Date: 02 MAY 2000   Initiats:                      ○ Full Path:                      u:\cod\str\phase4\wbwash\wmcgdr08.90p Drawing File Name:                      ...wmcgdr08.90p Units: Metric		<b>Index of Revisions</b> <table border="1"> <tr><td> </td><td> </td><td> </td><td> </td></tr> <tr><td> </td><td> </td><td> </td><td> </td></tr> <tr><td> </td><td> </td><td> </td><td> </td></tr> <tr><td> </td><td> </td><td> </td><td> </td></tr> </table>																		Colorado Department of Transportation  Room 330 4201 East Arkansas Avenue Denver, CO 80222 Phone: 303-757-9352 FAX: 303-757-9197 Staff Bridge Branch		As Constructed No Revisions: Revised: Void:		<b>WB I-70 OVER WASHINGTON STREET</b> BT1830 HAUNCH GIRDER SECTIONS Designer: T. RITZ                      Structure E-17-UW Detailer: K. PAWLICK                      Numbers Sheet Subset BRIDGE                      Subset Sheets: 837 of 80		Project No./Code IM 0704-191 12542 Sheet Number 176	

<sup>4</sup> Schematic provided by George Tsiouvaras, who worked on this project while at Carter Burgess. Measurements are in mm.

Finally, CDOT has in the past constructed "poured-in-place bridges" that have also effectively deterred pigeon roosting/nesting, although they may not be as long lived as those constructed with more modern techniques. Figures shows photos of the underside of I-70 east of the Coliseum and between Brighton Boulevard and Steele Street where the old poured box girders are still in place, but starting to deteriorate in some places (revealing their underlying construction) as shown in Figures 8 and 9.



**Figures 8 and 9. The underside of I-70 showing an old poured in place concrete structure that effectively deters pigeon nesting/roosting, but deteriorates over time.**

## **1.6 Devise and Conduct Field Experiments of Best Options to Deter Nesting**

Field experiments considered in this task address only the temporary deterrence of swallow nesting. The potential methods to be used were discussed and evaluated. The most effective methods to deter swallow nesting appear to be the following:

- a corner slope that converts the right angle at the top of a CBC wall or bridge abutment to a 45 degree angle by providing the hypotenuse of a triangle having equal sides of 6 inches or more on the ceiling and wall of a CBC (or abutment of a bridge).
- a hanging curtain attached to the ceiling of a CBC or bridge and hanging parallel to the CBC wall or bridge abutment and 5 inches from it, with the sides of the curtain secured to the CBC wall or bridge abutment to prevent swallows from nesting behind the curtain.
- netting, which is known to be an effective method. However, since it is the method currently used by CDOT, it does not need further testing. Data on its cost effectiveness should be compiled by CDOT for comparison with similar information for the tested methods.

Methyl anthranilate was also recommended for testing, but the equipment needed to apply it was very expensive and beyond the capability of this project. In addition, it would have required concurrence by the USFWS that it would not harm swallows. Even though use of this chemical is costly, requires more coordination, and needs a power

source, in some situations its ease of installation may make it the best choice if it is proven effective.

It was recommended in the Interim Report that field experiments using the two above methods and a control be conducted at the three parallel CBCs that extend under Storage Tek Drive just north of US 36 and near FlatIron Crossing Mall in Broomfield, Colorado. During the February 12 Study Panel discussion of these recommendations, a Study Panel member recommended that the ceiling of one CBC be painted blue as a third test method. To accommodate this additional method, a fourth CBC (slightly shorter and with a lower ceiling) that is less than 100 yards north of the three parallel CBCs chosen initially was also used (with the approval of the City & County of Broomfield). Figure 10 shows the relative location of the four CBCs used in this study.



**Figure 10. CBCs used in Field Test (the three parallel CBCs are on the left, partially obscured by trees; the fourth CBC is on the right and accessed via a sidewalk).**

Discussion of the details of the experimental setup occurred at the February 12, 2008 Study Panel Meeting. The resulting plans were summarized in a Work Plan to Test Temporary Swallow Nesting Deterrents and submitted in final version to CDOT on February 25, 2008.

In preparation for the field program, Ron Jones was met on February 26, 2008 at the site, where the CBCs requested for use were identified, the program was described, and permission to use the CBCs obtained. On March 14, Jeff Peterson (CDOT Headquarters environmental staff) helped to remove existing nests from the four test CBCs, each of which contained at least some nests although the CBC used as a control contained the fewest nests.

Primary installation of the deterrents was done on March 18, 2008. Additional deterrent installation was performed on March 28, 2008, when installation of the plastic curtains was completed, and the plastic corner slope panels were installed. As acknowledged below, installation was performed with excellent support from CDOT Region 4 maintenance staff, CDOT Headquarters environmental and research staff, and CDOT Region 4 environmental staff.

The Field Installation section of the Work Plan describes the construction details for each of the methods to be tested and how each was to be installed. The information in this

section, modified slightly by subsequent discussion and field expediency, resulted in the following installation protocol for the four CBCs, progressing from south to north<sup>5</sup>:

- A blue ceiling was created with a light blue paint that covers the ceiling and top 24 inches of the CBC wall. Application of exterior grade cement paint was done with a roller. This protocol was applied in the eastern third of the southernmost CBC.<sup>6</sup>



**Figure 11. Looking east from within CBC 1 (southernmost) with blue ceiling.**

- The hanging curtain was constructed of flexible 6 MIL plastic sheeting 24 inches high, cut into 8' lengths, and stapled to the 1" side of 1" x 2" x 8' boards. Variables in the curtain were color (clear or black), and wholeness (each 8-foot length left intact or cut into 2 inch vertical strips). The 8-foot lengths of plastic and wood (with vertical strips precut as appropriate) were assembled on saw horse "tables" in the field, but could be preassembled. The board was affixed with construction adhesive<sup>7</sup> to the top of the CBC within 5 inches of the wall and the edge of the plastic adjacent

---

<sup>5</sup> In the Interim Report and the Work Plan, the installation of AeroKret coated panels in areas where they would be exposed to extensive droppings was recommended to test their resistance to corrosion by droppings and the ease with which droppings could be removed from them. The AeroKret coated panels were not installed as part of the swallow test program because areas used by swallows were not exposed to extensive droppings. Rather, CDOT agreed to install these panels as part of some future scheduled maintenance at a location heavily used by pigeons

<sup>6</sup> This protocol was added to the field program as a result of February 12 Study Panel discussion.

<sup>7</sup> It was generally agreed in the meeting that a nonintrusive means of fastening the deterrent to the CBC walls (e.g., Liquid Nails) would be preferred. There was concern that drilling holes in the CBC cement could result in liability issues, if the CBC were later to develop structural faults.

to the CBC entrances was affixed to the CBC wall to prevent swallows from flying behind the curtain. They were propped in place by PVC pipe (.75" or 1" OD) slightly longer than the height of the CBC. Clear plastic sheeting was installed on the south side of the CBC and black on north side; 8' lengths of sheeting strips alternated with 8' lengths of solid sheeting on east end of south side; on west end of south side and on north side sheeting strips then solid sheeting were installed without alternation (Figure 9).



**Figure 12. Looking west in CBC 2 with plastic strips installed.**

- The northernmost of the three parallel CBCs was used as a control.



**Figure 13. Looking west in CBC 3 used as a control; this is the northernmost of the three parallel CBCs.**



- Two types of corner slope methods were used to eliminate the right angle at the top of the CBCs. The first corner slope method used a hypotenuse constructed with two tiers of a commercially available Bird Slide product. Each tier was 5 7/8 inches wide, so a double tier (with about a 1" overlap) resulted in a hypotenuse that was about 11" wide and touched the CBC ceiling and wall about 8" from the corner. Installation followed the manufacturer's guide to installing Bird Slide, which required 1/2" holes to be predrilled every 12" along each 4' length of the product. These holes were filled with a "mushroom" of GE Silicone II adhesive, which was also applied in a zig-zag bead down the 4' length. The Bird Slide was glued to the vertical wall of the CBC with the same adhesive (which allowed subsequent removal) and propped with PVC pipe as long as necessary. Bird Slide corner slopes were installed on the north side of the northernmost CBC.

The second corner slope method used a flexible 2' wide piece of plastic to cover the right angle with a concave arc. Each 2' by 8' plastic panel was held in place with strips of metal track that were affixed to 1"x2"x8' boards with roofing nails. Construction adhesive was used to affix the boards to the CBC ceiling and wall. This construction was used to allow the metal track, which has sharp edges, to be later removed by pulling the nails. The metal track was constructed of lengths of metal corner edging in which the right angle was closed somewhat to better hold the plastic. These strips of track were placed on the CBC ceiling and wall less than 17" from the right angle at the top of the CBC so that the plastic was flexed sufficiently to be held in place. As above, the boards were propped with PVC pipe as long as necessary. The plastic was not inserted behind the metal track until after the adhesive had cured sufficiently. In some places, irregularities in the CBC wall and metal track caused small gaps where the plastic panels abutted each other; these were rectified by adding a narrow (about 1' width) panel to cover the joint and/or using screw-gun screws to more precisely hold the plastic. The plastic corner slopes held by a metal V on lathe were installed on the south side of the northernmost CBC.

For both corner slope methods, plastic was used at the CBC entrances to close the space behind the slope so birds could not fly behind the Bird Slide or plastic (Figure 14).



**Figure 14. Looking west in CBC 4 with corner slope deterrents in place.**

The final deterrent installation task was completed on March 30, 2008. PVC pipes supporting the various deterrent installations were removed from all CBCs, and the various installations were checked to verify that they were ready to receive Cliff Swallows when they migrated back to the area.

## **2.0 RESULTS AND DISCUSSION**

Observation of the four test CBCs began on April 16, when swallows were first known to have returned to the Denver Metro Area. Cliff Swallows were first seen in the vicinity of the test CBCs on April 24th (the site was checked three times in the interim but no swallows were observed). Swallows were absent on April 25th (a cold and windy day), but seen on April 28th when the site was next visited. Swallows were seen thereafter whenever the site was visited during the summer 2008 nesting season (April 29 & 30; May 6, 13, 16, & 21; June 4 & 6). Table 5 presents the details of these observations.

**Table 5. 2008 Swallow Deterrent Data Sheets.**

Please complete this data sheet using waterproof ink or pencil

General Information		
Observer: D. Jean Tate		Weather Comment (clouds, barometer, visibility, changes, etc.): Forecast high and low=40/29 °F. Barometer 29.92 & rising. Humidity 45%. Clear blue sky when at site but haze in west and clouds building in mountains. Became overcast and started snowing several hours later.  Boulder (COOP 050848) actual high and low=31-76 °F, 0.23" rain melted snow, and 1.7" snow/ice pellets in 24 hours preceding observation at 17:00; 32 °F and 2" snow/ice pellets on ground and strong west wind at 17:00; day max temperature 48 °F.
Date: 16 April 2008	Temp: 41°F.	
Time: 10:00 am-12:00 noon	Wind: NE 16 mph	
Other Comment:: Swallows (probable violet-greens) observed by Paul and Lynn Kilburn over pond behind their house on West Woods Golf Course. Paul called me with information at 8:40 am. Went to site to check for swallows and to pick up PVC pipe. No swallows at site. All of our installation is intact. Plastic curtain sheets show tendency to stay folded where wind blown at the ends of each section. Where two sheets are together this can create a V exposing the wall behind. We'll see if this is a problem. Future solution would be to tape sheets together between sections or install one long curtain. Fringed curtain is flapping smoothly and returns to vertical when wind calms. It is also creating quite a bit of noise in the wind, which may be a further deterrent.  Mallard drake downstream of CBC triad. Two Red-winged Blackbirds in downstream cattails. Great Horned Owl has taken over the Red-tailed Hawk nest and the hawk is nowhere to be seen.		

General Information		
Observer: D. Jean Tate		Weather Comment (clouds, barometer, visibility, changes, etc.):  Boulder (COOP 050848) actual high and low=28-50 °F, 0.15" rain melted snow, and 1.8" snow/ice pellets in 24 hours preceding observation at 17:00; 49 °F and 0" snow/ice pellets on ground at 17:00; wind SW just before 1600 MST.
Date: 17 April 2008	Temp:	
Time: 11:15-11:35 am	Wind:	
Other Comment: No swallows present in area. Great Horned Owl on nest. Starlings in area.		

General Information		
Observer: D. Jean Tate		Weather Comment (clouds, barometer, visibility, changes, etc.):  Boulder (COOP 050848) actual high and low=34-78 °F, 0" rain melted snow, and 0" snow/ice pellets in 24 hours preceding observation at 17:00; 75 °F and 0 snow/ice
Date: 19 April 2008	Temp:	
Time: 1:15-1:35 pm	Wind:	

		pellets on ground and afternoon breezy with relative humidity<10% at 17:00.
Other Comment: No swallows present in area. Great Horned Owl on nest. Three pigeons in flight.		

General Information		
Observer: D. Jean Tate		Weather Comment (clouds, barometer, visibility, changes, etc.):  Boulder (COOP 050848) actual high and low=32-68 °F, 0" rain melted snow, and 0"snow/ice pellets in 24 hours preceding observation at 17:00; 50 °F and 0" snow/ice pellets on ground 17:00; day max temperature 58 °F.
Date: 21 April 2008	Temp:	
Time: 2:30-2:50 pm	Wind:	
Other Comment: No swallows present in area. Great Horned Owl on nest. Western Meadowlark, Black-billed Magpie, Red-winged Blackbirds observed. L. Kilburn called in evening to report a few Violet-green Swallows had been flying over the West Woods pond in the morning.		

General Information		
Observer: D. Jean Tate		Weather Comment (clouds, barometer, visibility, changes, etc.):  Boulder (COOP 050848) actual high and low=29-69 °F, 0" rain melted snow, and 0"snow/ice pellets in 24 hours preceding observation at 17:00; 67 °F and 0" snow/ice pellets on ground at 17:00.
Date: 22 April 2008	Temp:	
Time: NA	Wind:	
Other Comment: Swallows not checked at CDOT Test CBCs. L. Kilburn called to note that Violet-green Swallows have arrived in Bailey.		

General Information		
Observer: D. Jean Tate		Weather Comment (clouds, barometer, visibility, changes, etc.):  Boulder (COOP 050848) actual high and low=40-72 °F, 0" rain melted snow, and 0"snow/ice pellets in 24 hours preceding observation at 17:00; 58 °F and 0" snow/ice pellets on ground and dusty at 17:00; day max temperature est. at 67 °F; NCAR-ML=44 mph near obs. t.
Date: 24 April 2008	Temp:	
Time: 1:15-1:45 pm	Wind:	
Other Comment: Swallows have arrived in vicinity of CDOT Test CBCs. About 40-50 swallows in area flying in small to large groups. They are feeding and returning to the culvert under Midway Blvd. None went near our test CBCs.		
Robin, Say's Phoebe, 2 Great Horned Owl young, 1 pair of Black-billed Magpies, 2 pair Mourning Doves, 1 Red-winged Blackbird male observed. Lots of fresh dirt near some prairie		

dog burrows—spring cleaning!

General Information		
Observer: D. Jean Tate		Weather Comment (clouds, barometer, visibility, changes, etc.): Cold and very windy
Date: 25 April 2008	Temp: ~50 °F.	
Time: 2:00-2:20 pm	Wind:	Boulder (COOP 050848) actual high and low=34-58 °F, 0" rain melted snow, and 0"snow/ice pellets in 24 hours preceding observation at 17:00; 52 °F and 0" snow/ice pellets on ground at 17:00.
Other Comment: No swallows present in area. Owl hunkered down. Magpie observed plus a cormorant on the updrafts.		

General Information		
Observer: D. Jean Tate		Weather Comment (clouds, barometer, visibility, changes, etc.):
Date: 28 April 2008	Temp:	
Time: ~3:00-3:20 pm	Wind:	Boulder (COOP 050848) actual high and low=32-73 °F, 0" rain melted snow, and 0"snow/ice pellets in 24 hours preceding observation at 17:00; 72 °F and 0" snow/ice pellets on ground at 17:00.
Other Comment: Two male Red-winged Blackbirds, Great Horned Owls on nest, Breat Blue Heron, male Mallard, Red-tailed Hawk soaring, Starling, Say's Phoebe, Grackles pigeons, Mourning Doves, Robin observed. Finally, about 40 swallows (cliff—as all swallows observed at site have been...) feeding overhead—stayed in loose feeding flock. They came into the area about three times. Never went into the culvert under Midway Blvd. or near our four test CBCs.		

General Information		
Observer: D. Jean Tate		Weather Comment (clouds, barometer, visibility, changes, etc.):
Date: 29 April 2008	Temp:	
Time: ~11:45 am-12:15 pm	Wind:	Boulder (COOP 050848) actual high and low=45-77 °F, 0" rain melted snow, and 0"snow/ice pellets in 24 hours preceding observation at 17:00; 75 °F and 0" snow/ice pellets on ground at 17:00.
Other Comment: Adult owl sitting high. Four Red-winged Blackbirds on main marsh plus 1 female; two Red-winged Blackbirds on small marsh near entrance of CBC#4. Three Robins, Mourning Dove, Black-billed Magpie, male Mallard, pigeons observed. About 40 swallows flying high and then swooping into CBC under Midway Blvd. Seem to be flying into the culvert from a very low altitude—wonder if they are picking up mud from the floor of the CBC. Definitely going from high in the air into CBC without stopping. No activity near any of our test CBCs.		

General Information		
Observer: D. Jean Tate		Weather Comment (clouds, barometer, visibility, changes, etc.):  Boulder (COOP 050848) actual high and low=45-80 °F, 0" rain melted snow, and 0"snow/ice pellets in 24 hours preceding observation at 17:00; 75 °F and 0" snow/ice pellets on ground at 17:00; relative humidity near 10% in afternoon.
Date: 30 April 2008	Temp:	
Time: ~10:30-10:55 am	Wind:	
Other Comment: Waited about 25 minutes at the site. A larger flock of swallows (~100 birds) appeared several times. Feeding at moderate to very high altitude. Never entered any CBC while I watched. Six Red-winged Blackbirds on big marsh. Red-tailed hawk, 2 Mallards, Mourning doves, owls on nest observed. Great Blue Heron flew off from near Midway CBC. Frogs calling.		

General Information		
Observer: D. Jean Tate		Weather Comment (clouds, barometer, visibility, changes, etc.): No precipitation. Partially cloudy.  Boulder (COOP 050848) actual high and low=41-76 °F, 0" rain melted snow, and 0"snow/ice pellets in 24 hours preceding observation at 17:00; 71 °F and 0" snow/ice pellets on ground at 17:00.
Date: 6 May 2008	Temp: 47-77	
Time: ~1:15-1:35 pm	Wind:	
Other Comment: Owls appear to be gone. Killdeer along path to CBC 4. Four male Red-winged Blackbirds and one female. About 50 Cliff Swallows came into view, finally. Two were in Midway CBC and flew out as I approached. Others stayed high in the air.  I walked through CBC #1 and looked at CBCs #2, 3, and 4 from the entrance. No signs of any swallow activity.		

General Information		
Observer: D. Jean Tate		Weather Comment (clouds, barometer, visibility, changes, etc.): Precipitation=0.78 inches. Cloudy  Boulder (COOP 050848) actual high and low=34-59 °F, 0.72" rain melted snow, and trace snow/ice pellets in 24 hours preceding observation at 17:00—before noon; 53 °F and 0" snow/ice pellets on ground at 17:00; afternoon max temperature 53 °F.
Date: 13 May 2008	Temp: 37-52	
Time: ~12:25-12:50 pm	Wind:	
Other Comment: About 60 Cliff Swallows seen twice in 25 minutes I was there. Soaring high and feeding. Did not come down to Midway Blvd. or test culverts.  Twelve white pelicans soaring into pond east of railroad track.		

General Information		
Observer: D. Jean Tate		Weather Comment (clouds, barometer, visibility, changes, etc.): Changeable day—cloudy when I was at the site.. No precipitation  Boulder (COOP 050848) actual high and low=39-71 °F, 0" rain melted snow, and 0"snow/ice pellets in 24 hours preceding observation at 17:00; 68 °F and 0" snow/ice pellets on ground at 17:00.
Date: 16 May 2008	Temp: 41-73	
Time: ~6:00-6:25 pm	Wind: Windy	
Other Comment: Cliff Swallows (~60+) flying low and repeatedly entering Midway Blvd. CBC—some swooping close overhead as we (Riley & I) sat on bank looking into CBC #4. No swallow activity near any of the test culverts except on two occasions over the course of about 25 minutes, I saw one swallow swoop into CBC #4 and back out—flying at mid level and foraging. It showed no interest in the walls of the CBC.		

General Information		
Observer: D. Jean Tate		Weather Comment (clouds, barometer, visibility, changes, etc.): No precipitation  Boulder (COOP 050848) actual high and low=53-81 °F, 0" rain melted snow, and 0"snow/ice pellets in 24 hours preceding observation at 17:00; 79 °F and 0" snow/ice pellets on ground at 17:00; gusty SW wind in late afternoon.
Date: 21 May 2008	Temp: 58-87	
Time: 6:10-6:30 pm	Wind: Windy	
Other Comment: About 30-40 Cliff Swallows flying in and out of Midway Blvd. CBC. Steady activity. Don't know if numbers actually lower or if smaller percentage of birds were present at any one time. No sign of activity at test CBCs.		

General Information		
Observer: D. Jean Tate		Weather Comment (clouds, barometer, visibility, changes, etc.): Precipitation= 0.41 inches. Cloudy.  Boulder (COOP 050848) actual high and low=50-72 °F, 0.02" rain melted snow, 0"snow/ice pellets, and thunder in 24 hours preceding observation at 17:00; 63 °F and 0" snow/ice pellets on ground at 17:00.
Date: 4 June 2008	Temp: 49-67	
Time: 7:45-9:00 am	Wind:	
Other Comment: Sat and watched for 30 minutes then walked the length of all culverts and took photos. No swallow activity near any of the test CBCs and no signs of nesting activity inside any of the CBCs. About 100 Cliff Swallows in the air out of the Midway Blvd. CBC, once as I arrived at the site (don't know what made them all fly that time...) and once when I approached to take photos into the CBC entrance. Observed five Red-winged Blackbirds in the big marsh and two in the small marsh; one White Pelican, 1 Killdeer, one Red-tailed Hawk (probably nest west of Storage Tech Drive across from test CBCs), one male Mallard, two Grackles, one Say's Phoebe (near test CBC#4).		



General Information		
Observer: D. Jean Tate		Weather Comment (clouds, barometer, visibility, changes, etc.): No precipitation..  Boulder (COOP 050848) actual high and low=45-77 °F, 0" rain melted snow, and 0"snow/ice pellets in 24 hours preceding observation at 17:00; 71 °F and 0" snow/ice pellets on ground at 17:00.
Date: 6 June 2008	Temp: 44-80	
Time: 8:45-9:30 am	Wind: Windy	
Other Comment: Watched for 30 minutes then walked and took a few more photos to supplement those taken on 4 June 2008. Continuing high Cliff Swallow activity at the Midway Blvd. CBC. No activity associated with any of our test CBCs. At Midway CBC higher numbers of swallows seem to come and go in waves of sometimes—they are definitely groupies. When a Grackle landed in the grass in the big marsh, all the Red-winged Blackbirds gathered around the spot and scolded (males first then females joined in), but it didn't leave (at least not while I was watching). Killdeer ground display on bare dirt near prairie dog hole was neat to see.		

Even though swallows were observed in the vicinity of the test CBCs, with one minor exception, swallows were never seen in or near any of the four test culverts including the control. The minor exception occurred on May 16 when a single Cliff Swallow flew just inside the entrance of CBC 4 (which is furthest north) where it appeared to be catching insects. It showed no interest in the walls of the CBC. Instead of visiting the test CBCs, all of the Cliff Swallows in the area used a CBC beneath Midway Boulevard and just south of the walkway that goes from Midway Boulevard to CBC 4 (Figure 15). This CBC has hundreds of nests in it (Figure 16), and Cliff Swallows were seen entering this CBC on April 24th, the first day they were observed at the site. They continued to fly in and out of this CBC, sometimes individually and sometimes in large numbers, throughout the summer field observations. Communal group flights of these Cliff Swallows occurred especially early in the nesting season; later in the nesting season when birds were tending their nests and young, the swallows acted more independently, unless the CBC was disturbed. This appeared to be the only place Cliff Swallows were nesting in the immediate vicinity.

On most visits, the CBC entrances were observed with binoculars from a slope just north of the walkway leading to CBC 4. The full length of CBC 1 was walked on May 6 and the other test CBCs were inspected with binoculars from their entrances. The entire length of all four test CBCs was walked on June 4 and photographs were taken.



**Figure 15. Looking west with swallows (the dark specks in the center of the photo) about the entrance of the occupied non-test CBC (the top of which is in the foreground at the tip of the red arrow). CBC 3 is in the background. CBCs 1 and 2 are behind the vegetation to the left of CBC 3 and CBC 4 is out of the photo in the background to the right (north).**



**Figure 16. Active swallow nests in fifth CBC. Note swallow occupant in top row**

Since there was no nesting in any of our test CBCs and all area nesting occurred in an undisturbed fifth CBC that was nearby and contained existing nests, no final conclusions could be drawn regarding the effectiveness of the deterrents tested in our study at the end of 2008. While there was insufficient money left in the budget to fully continue the study through additional nesting seasons and potential population fluctuations or to add additional studies to test other factors systematically, some further checking of the current approach could yield additional information.

Thus, it was decided that any consultant time beyond that needed to complete deliverables and remove the deterrents at the end of the study would be spent rechecking the site over the winter (to see how the deterrents hold up to weather) and spring (to see whether any and which of the test CBCs are used by swallows). Approval to leave the deterrents in place until the fall of 2009 was obtained on January 16, 2009 from Ron Jones of the City of Broomfield.

The test CBCs were visited four times in 2009 and the field sheets are included as Table 6.

**Table 6. 2009 Swallow Deterrent Data Sheets.**

Please complete this data sheet using waterproof ink or pencil

General Information		
Observer: D. Jean Tate		Weather Comment (clouds, barometer, visibility, changes, etc.):
Date: January 2, 2009	Temp:	
Time: 1:20-1:40 pm	Wind:	
Other Comment: Visited site to determine how various deterrents were holding up to winter weather. Strong winds had hit the area on the evening and night of 29 December and into 30 December, with gusts recorded up to 77 mph in south Boulder and 74 mph at Rocky Mountain Metropolitan Airport on the morning of 30 December. Arvada, to the south of the site, recorded all time average high wind gusts of 39.1 mph on 30 December 2008.		
Damage was sustained primarily by the corner slope methods. The Bird Slide product had been attached with GE Silicone II because the intent was to remove (and potentially reuse) this product.		

General Information		
Observer: D. Jean Tate		Weather Comment (clouds, barometer, visibility, changes, etc.): Partly cloudy. Weather data recorded from forecast on day of visit. Actual in Broomfield was 35-57 oF with 8-18 mph (NE) wind gusting to 23 mph. (data from wunderground.com).
Date: April 9, 2009	Temp: 27-56 oF range	
Time: 3:30-4:30	Wind: S @ 10-20 mph	

Other Comment: No swallows observed in the area.

General Information		
Observer: D. Jean Tate		Weather Comment (clouds, barometer, visibility, changes, etc.): No precipitation and 20 mile visibility at Broomfield. Weather data obtained from <a href="http://www.wunderground.com/history/airport/KBJC/2009/5/14/DailyHistory.html?req_city=Broomfield&amp;req_state=CO&amp;req_statename=Colorado">http://www.wunderground.com/history/airport/KBJC/2009/5/14/DailyHistory.html?req_city=Broomfield&amp;req_state=CO&amp;req_statename=Colorado</a>
Date: May 14, 2009	Temp: 42-72	
Time: 11:00-12:30	Wind: 4-13 mph (NW)	
Other Comment: Swallows seen in the area. Still in loose but cohesive communal flock like they were last spring before nests were occupied. Swooped down into occupied CBC in large groups then left together. No swallows seen in the vicinity of the test CBCs. In the northernmost CBC a pair of Say's Phoebes were flying in and out repeatedly and landing in the flat space provided by the attachment triangle behind one of the Bird Slide panels. Suspect they will nest there.		

General Information		
Observer: D. Jean Tate		Weather Comment (clouds, barometer, visibility, changes, etc.): Blue sky, scattered clouds, high visibility. Clouds starting to spill over Front Range in vicinity of Mt. Evans, but few near study area. Arvada high temperature for the day is 74 and it was all of that at the study area even though it was before noon when we sat to watch for a while (10:24-10:40 am) Broomfield forecast said 67 oF forecast but 76-77 RealFeel. I believe the latter.
Date: August 18, 2009	Temp: ~74	
Time: 9:30-11:00	Wind: Light breeze S-SSW, 2-3 mph	
<p>Other Comment: More (12) of the Bird Slide have fallen down from the N side of the northernmost CBC so that there are only 5 panels plus both end caps left. One of the endcaps (downwind one) was still connected to a panel. The duct tape was effective in helping the panels stay together and three that came down were still somewhat connected by the tape. This may have helped them stay up, but also facilitated their all three coming down together.</p> <p>Swallows have moved into that side in many of the spaces between the remaining panels. There were 45 completed nests in all plus more that were incomplete/collapsed.</p> <p>On the S side of that CBC one-half to two-thirds of the white paneling is still up, with one paneling strip dangling but not blown out of the grooves because of two screws that had been added. There were 3 complete nests on this S side in the spaces between the panels. Also, one of the remaining Bird Slide panels had a nest on the flat space provided by the top of the attachment triangle—I had seen a pair of Say’s Phoebe’s looking very interested in that spot on an earlier visit.</p> <p>There were no swallows observed in the vicinity during my visit and no nests in any of the other three CBCs. The plastic strips were still intact.</p> <p>I think this partial reoccupation by swallows is great news, and evidence of the effectiveness of the corner slope method since the birds moved in where our deterrents had blown down! Also the phoebe nest indicates the importance of the end caps.</p> <p>Photos taken of corner slope panels, nests, and three of four CBCs. Test CBC was not photographed as there was nothing to document. All 4 CBCs were walked through, end to end.</p> <p>I walked down to the CBC under Midway Blvd. Nearly all of the nests had whitewash at their entrances. I would say it was a very good year for swallows. I could hear bird noises from deep in that CBC, but I think these were blackbirds in the trees at the far end of the CBC. They did not sound like swallows. A few Red-winged Blackbirds in the cattail marsh (which looked to have expanded a bit due to the wet summer) and a Red-tailed Hawk called from somewhere in the sky. Prairie dogs have been contained by a ~2 ft high chickenwire fence around the marsh, and appear to have been exterminated and the burrows collapsed outside the fence on the north side of the sidewalk leading to the northernmost CBC. Also appear to have been exterminated on the east side of S. 96th Street in the space between the 3 southern and northernmost CBCs.</p>		

- There had been a major wind storm in the area on December 30, 2008 with all time average high wind gusts of 39.1 mph recorded in Arvada about 6 miles to the south.

Therefore the site was visited on January 2 to see whether the deterrents had been damaged by the wind or other weather since the last visit on June 6, 2008. Damage was sustained primarily by the corner slope methods, especially by the Bird Slide product, which had been attached with GE Silicone II for ease of removal (Figures 17 and 18). The plastic strips remained intact in CBC 2, and the paint in CBC 1 appeared unchanged (Figure 19).



**Figure 17. Bird Slide panels and white plastic panels collected after December 2008 wind storm.**



**Figure 18. Corner slope status after December 2008 wind storm; looking east down CBC 4.**



**Figure 19. Status of plastic strip deterrents after December 2008 wind storm.**

- The site was visited again on April 9, 2009 (when no swallows were observed in the area).
- On May 14, 2009, swallows were observed in the area. The May swallow observation was of loose but cohesive communal flocks that swooped into the CBC beneath Midway Boulevard that was used for nesting in 2008, but did not go near the test CBCs. A pair of Say's Phoebes were seen repeatedly in CBC 4, the northernmost test CBC, where they were exploring a flat place provided by the attachment triangle behind one of the Bird Slide panels and exposed because the adjacent panel had blown down.
- The site was visited for a final time in 2009 on August 18th, by which time 12 additional Bird Slide panels had fallen down, leaving only 5 panels plus the end caps on the north side of CBC 4 (Figures 20 and 21). On the south side of CBC 4, one-half to two-thirds of the white plastic panels were still in place, with one plastic panel dangling but still partially in the metal track because of two screws that had been added (Figures 22 and 23).



**Figure 20. Looking west down CBC 4 from the CBC entrance on August 18, 2009.**



**Figure 21. Looking west down CBC 4 from within the CBC on August 18, 2009.**



**Figure 22. The two screws that kept the white plastic panel in CBC 4 from falling out completely.**





**Figure 23. How the white plastic panel was held into the metal grooves in CBC 4.**

However, the most important August observation was that swallows had moved into the spaces left by blown down Bird Slide and white plastic panels! On the north side of the CBC where most of the deterrents were gone, there were 45 completed swallow nests and more that were incomplete/collapsed (Figures 24 and 25).



**Figure 24. The north side of CBC 4 showing the space west of the last Bird Slide panel and the nests near the west end of the CBC.**



**Figure 25. The north side of CBC 4 showing a closer view of the nests near the west end of the CBC.**

There was also a used fibrous nest on top of the attachment triangle where the phoebes were seen in May (Figure 26). On the south side of the CBC where most deterrents were still in place, there were three complete swallow nests in the spaces between the white plastic panels (Figure 27).



**Figure 26. Nest of Say's Phoebe on top of triangular Bird Slide attachment.**



**Figure 27. Swallow nests on the south side of CBC 4 in the space where white plastic panels had fallen down.**

CBC 1 with the blue ceiling (Figure 28) and CBC 2 with the plastic strips (Figure 29) were unchanged. Swallows again nested abundantly in the CBC under Midway Boulevard, where most of the nests observable from the CBC entrance had white wash at their entrances (Figure 30).



**Figure 28. The status of the blue paint in CBC 1 on August 18, 2008.**



**Figure 29. The status of the plastic strips in CBC 2 on August 18, 2008.**



**Figure 30. Nests in the non-test CBC under Midway Boulevard showing their density and the whitewash at their entrances.**

Since leaving the deterrents in place produced interesting results in 2009, Ron Jones was contacted on December 7, 2009, to see if we could leave the deterrents in place through another winter and nesting season. He agreed, but said the deterrents should be removed in 2010 because the number of people in the area would be increasing because the buildings being constructed nearby would then be occupied. Leaving the deterrents in place into 2010 will allow tracking the deterrents through another winter to see how they hold up and also let us see whether swallows again occupy CBC 4 and perhaps expand elsewhere. It was noted during the conversation that if the swallows do occupy the test CBCs the deterrents could not be removed until their nesting season was over in the fall, but otherwise the deterrents could be removed in about June. It was agreed that Ron Jones would be called again in late spring to assess the 2010 swallow situation at that time.

### 3.0 CONCLUSIONS

Since in 2008 there was no nesting in any of our test CBCs and all area nesting occurred in an undisturbed fifth CBC that was nearby and contained existing nests, no final conclusions could be drawn regarding the effectiveness of the deterrents tested in our study during 2008. The fifth CBC contained hundreds of nests in several rows below both top corners of the CBC, while the nests removed from the test CBCs had been sparsely distributed along the CBCs and may have been occupied by a population overflow from the fifth CBC. It is likely that the fifth CBC was the "home base" for this swallow population and that this history plus the presence of existing nests were the primary attractants to the fifth CBC, which could accommodate all the returning swallows that nested in the area. However, there is no way to know whether the swallows would have nested in any of the non-control test CBCs had they not contained deterrents—or alternatively whether they would have nested in any of the non-control test CBCs if they still contained deterrents but the nests in the fifth CBC had been removed. The absence of nests in the control CBC suggests that the spring 2008 swallow population was not large enough to require nest sites beyond the fifth CBC, but a number of other factors could also have contributed to these unexpected results.

The summer of 2009 was apparently a very good year for swallows and the colony under Midway Boulevard was able to expand into the parts of CBC 4 where deterrents were lacking. It was apparent that swallows will occupy CBCs where corner slope deterrents have been partially removed, but occupy only the spaces where the deterrents are absent. This indicates that the corner slope deterrents are effective in keeping swallows from nesting and also that if gaps in the corner slope deterrents occur, they may be occupied. Thus, when corner slope deterrents are used, they must be well maintained. Neither CBC 1 with the painted ceiling or CBC 2 with the black and white plastic strips was occupied by nesting swallows in 2009. Thus, these deterrents may have been effective in discouraging swallow nesting. The plastic strips certainly provide an uninviting swallow nesting environment from the perspective of the people involved with this project. Nonetheless, some other aspect of CBC 1 and 2 or of the swallow population could have discouraged swallow nesting there in 2009.

Finally, the protocols for installing our various deterrents appeared to have worked as intended.

- The paint and plastic strips are long lived and have withstood considerable wind and weather. The plastic strips are probably the least expensive deterrent in terms of the labor and material costs to put them in place.
- The approach used to install the white plastic panels worked reasonably for a single season's use, but would have been improved by the consistent use of screws to attach the plastic panels to the metal track and underlying wood strips. Even with the use of screws, these plastic panels and the metal track could be readily removed.
- Similarly, the use of GE Silicone II worked to keep the Bird Slide panels in place for a single season's use and also enabled them to be removed and potentially reused.

The white plastic panels are less expensive in terms of materials than the Bird Slide panels, but may require slightly more labor.

- The white plastic panels are easier to install because they can be put up in two stages and present less problem in getting the adhesive to hold, although this requires two trips to the site. The white plastic panels can also be removed to allow swallow nesting and then replaced in the metal track if these are left in place. However, if the track is to be left in place, an alternative material that lacks sharp edges should be used to construct it.

More testing is needed before the effectiveness of each of these deterrent methods is shown conclusively. The results of any further observations of the deterrents and nesting activity at the site for this project are included in a brief Addendum Report, which is attached as Appendix A.

## 4.0 REFERENCES

Analytical Services & Materials, Inc. Dr. R. Sivakumar. 107 Research Dr., Hampton, VA, 23666, 757-865-7093 ext. 304. Product information. [www.asm-usa.com](http://www.asm-usa.com).

Arkansas State Highway and Transportation Department. TRC-0501 Evaluation of Passive Bird Deterrent Devices to Minimize Nesting on Bridges and Culverts.

Bird B Gone Inc. Product information. <http://www.birdbgone.com/>.

BirdTec, Inc. Product information. <http://www.aviancontrol.com/>.

Derby City Council. Peregrine information.  
[http://www.derby.gov.uk/LeisureCulture/MuseumsGalleries/EnvironmentalProjects/Technical\\_Info.htm](http://www.derby.gov.uk/LeisureCulture/MuseumsGalleries/EnvironmentalProjects/Technical_Info.htm)

Dipcraft Manufacturing Company. Fiberglass panel product information.  
<http://www.dipcraft.com/pricing.html>.

Edison Electric Institute. Avian information.  
[http://www.eei.org/industry\\_issues/environment/land/wildlife\\_and\\_endangered\\_species/AvianProtectionPlanGuidelines.pdf](http://www.eei.org/industry_issues/environment/land/wildlife_and_endangered_species/AvianProtectionPlanGuidelines.pdf).

FMH Material Handling Solutions. Material handling information.  
<http://www.theonlinecatalog.com/fmhsolutions/store/search.asp>.

Gardenocity. Repellent information.  
<http://www.provenrepellents.com/products.php?catID=2>.

iVillage Garden Web. Stainless steel flashing information.  
<http://ths.gardenweb.com/forums/load/build/msg1020133718209.html>.

Jacob, J.P., J.M. Gaskin, H.R. Wilson, and F.B. Mather. 1997. Document PS23, Animal Science Department, Florida Cooperative Extension Service, Institute of Food and Agricultural Sciences, University of Florida.  
<http://edis.ifas.ufl.edu/pdffiles/PS/PS01900.pdf>.

McMaster-Carr. Stainless steel flashing product information.  
<http://www.mcmaster.com/#type-316-stainless-steel/=agd9g>.

Nixalite, Inc. Product information. <http://www.nixalite.com/>.

Old House Web. Roof flashing information. <http://www.oldhouseweb.com/how-to-advice/roof-flashing-details.shtml>.

Oregon Department of Transportation. Repellent information.

<http://www.oregon.gov/ODOT/HWY/REGION1/news/OrchardCannonsonI5Bridge092506.pdf>.

Simmons Pest Management, Inc. Product information.

[http://www.critterriders.com/pigeon\\_trap.htm](http://www.critterriders.com/pigeon_trap.htm)

Ultimate Bird Control LLC. Bird Slide product information. 866-482-4737.

United States Department of Agriculture. Animal and Plant Health Inspection Service.

<http://www.aphis.usda.gov/>.

University of New Mexico. Raptor information.

[http://www.raptor.cvm.unm.edu/raptor/education/lessonplans/lessons4-9/lesson8/osprey\\_platform/home.html](http://www.raptor.cvm.unm.edu/raptor/education/lessonplans/lessons4-9/lesson8/osprey_platform/home.html).

.



## APPENDIX A - ADDENDUM REPORT

# ADDENDUM TO FINAL REPORT RESEARCH STUDY PROGRESS REPORT: BIRD NESTING AND DROPPINGS CONTROL ON HIGHWAY STRUCTURES, STUDY NO: 41.76

Prepared by:  
D. Jean Tate  
Enviro-Support, Inc.  
303-403-4748  
7485 Quartz Street  
Arvada, CO 80007

Sponsored by the:  
Colorado Department of Transportation  
In Cooperation with the:  
U.S. Department of Transportation  
Federal Highway Administration

September 2010

Prepared for:



Colorado Department of Transportation  
DTD Applied Research and Innovation Branch  
4201 East Arkansas Avenue  
Denver CO 80222  
(303) 757-9506

The following is a an ADDENDUM to the Final Report prepared for Colorado Department of Transportation (CDOT) Research Study Progress Report: Bird Nesting and Droppings Control on Highway Structures, Study No: 41.76.

Per specifications of the Statement of Work (SOW), this Final Report included a summary of progress as of December 31, 2009 on the Tasks in the SOW. As of the date of the Final Report, the swallow deterrents had not been removed.

This ADDENDUM addresses subsequent observations of note on these deterrents in 2010 and the removal of the deterrents on September 23, 2010.

The test site for temporary swallow nesting deterrents was visited on April 16, June 20, and September 23, 2010 by D. Jean Tate (Enviro-Support, Inc.). The observations made during these visits are summarized in Tables 1 through 3, respectively. These following observations are most important:

- Swallows were not present in the area on April 16th.
- The CBC under Midway Blvd. was quite active on June 30th, but there was no activity in any of the test CBCs.
- The presence of whitewash on the floor of the northernmost CBC and a bit at the lip of some nests indicated these nests could have been used early in the season but, if so, the colony did not expand or have second clutches.
- When several nests were examined during the removal of deterrents in the northernmost CBC, two of them contained unhatched eggs and two contained seemingly recent grassy debris indicating probable use of these nests in summer 2010.
- One dead adult swallow was found that became tangled in a piece of wire protruding from the ceiling of the CBC. This had not been observed on previous visits, further supporting the likelihood that this CBC was used for nesting in 2010.
- The effectiveness of the corner slopes in deterring swallow nesting was proven by the building of swallow nests only where these deterrents had been blown down.

**Table 1**  
**SWALLOW DETERRENT DATA SHEET**  
**CDOT Study #41.76**

Please complete this data sheet using waterproof ink or pencil

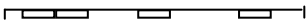
General Information		
Observer: D. Jean Tate		Weather Comment (clouds, barometer, visibility, changes, etc.): Windy cloudy afternoon. The average temperature range in April in Broomfield is 33-61 degrees.
Date: 16 April 2010	Temp: ~60°F	
Time: 3:25-3:55 pm	Wind: ~20 mph	
<p>Other Comment: No swallows seen in the vicinity. In the northernmost test CBC, which has the corner-slope methods in it, the only remaining Bird Slide product on the north side was four panels and the two end pieces as shown in the drawing to the right, which is oriented with the west end to the left.</p> <div style="text-align: center;">  </div> <p>The south side of this CBC was unchanged and the one plastic panel that was hanging loose but held by two hex screws is still present. The plastic strips are intact in the middle of the southern group of 3 CBCs. Several photos were taken of these conditions. Flicker and 3 male Red-winged Blackbirds were in the vicinity. The cloudy weather had quieted things down. Even the prairie dogs were quiet except in the graded field to the north.</p>		

[Swallows were observed at Rocky Mountain Arsenal NWR on May 9th and several observers there said they had first seen swallows during the week prior.]

**Table 2**  
**SWALLOW DETERRERENT DATA SHEET**  
**CDOT Study #41.76**

General Information		
Observer: D. Jean Tate		Weather Comment (clouds, barometer, visibility, changes, etc.): . Cloudless except for cumulus clouds building along the foothills.
Date: 30 June 2010	Temp: 89oF	
Time: 4:14-4:40 pm	Wind: not noticeable	
<p>Other Comment:</p> <p>Site visited again on June 30th. Only the northernmost test CBC was checked. The south side of the same, but one more panel was found on the ground, so either I missed picking it up on April 16th or one more of the panels illustrated above was double at that time and has fallen in the interim. NO swallows or other activity in the northernmost test CBC. The phoebe nest was still in place on the more eastern of the two middle slides. Dripping water was the only sound in the CBC except for the red-winged blackbirds in the adjacent marsh. Thirty-seven complete nests still on north side of CBC, plus several that are incomplete or have broken down. Still whitewash on CBC floor and a bit at the lip of some nests. These nests could have been used early in the season but, if so, the colony here did not expand or have second clutches.</p> <p>Nests in the CBC under Midway Blvd were still very active, with 50-100 swallows in the air at times and seemingly entering that CBC from both sides of the road. Swallows exhibiting group flight activity similar to that engaged in when they first arrive....typically flying about in groups of about 10 or more rather than in individually independent flight.</p>		

**Table 3**  
**SWALLOW DETERRERENT DATA SHEET**  
**CDOT Study #41.76**

Please complete this data sheet using waterproof ink or pencil

General Information		
Observer: D. Jean Tate		Weather Comment (clouds, barometer, visibility, changes, etc.): Sunny, no clouds.
Date: 23 September 2010	Temp: 60-78°F	
Time: 7:15- 11:30	Wind: ENE, minimal, slight breeze as the morning warmed.	
<p>Other Comment:</p> <p>No swallows present in the vicinity. Jeff Peterson of CDOT and I met at about 7:15 am to remove the deterrents. We started in the northernmost CBC and removed the bird slides on both sides of the culvert. The following observations were of interest:</p> <p>One dead adult swallow whose wing had become caught in a piece of wire protruding from the CBC ceiling was found in a nest on the south side of this CBC;</p> <p>The contents in about 10 of the nests on the north side of this CBC were checked—while most of these nests were empty, two of the nests contained a single unhatched egg and two contained seemingly recent grassy debris indicating probable use of these nests in summer 2010</p> <p>Photographs were taken of the culvert before the remaining corner slope deterrents were removed. No further material had blown down since the last visit.</p> <p>Use of short screws rather than nails to attach the metal grooves to the wooden lath in the non-commercial corner slopes constructed of flexed plastic would make them much easier to remove. These same screws, when used occasionally to hold the flexed plastic in place worked extremely well in holding the plastic and even after two winters were easy to remove. It might also be possible to remove the top inside corner off the wooden lath before it is glued in place and forego the metal grooves which are difficult to work with. Whether this arrangement would hold up to wind would need to be tested.</p> <p>The 1 x 2 inch wooden lath used as part of the corner slopes on the south side of this CBC will remain as agreed with Ron Jones, City of Broomfield.</p> <p>Of the three parallel CBCs further south, only the middle one contained a removable deterrent. The southernmost of the three CBCs had its ceiling painted blue and will remain unchanged as agreed with Ron Jones, City of Broomfield. The northernmost of the three CBCs was used as a control and contained no deterrents. The middle CBC contained 2-foot high plastic sheets, half of which were cut vertically into 3 inch strips. These plastic sheets were removed with the following observations of interest:</p> <p>Both the black and clear plastic held up well through three breeding seasons and two winters.</p> <p style="padding-left: 40px;">The black plastic appeared slightly more flexible when it was taken down and might ultimately hold up better through a longer time in the field.</p> <p>The use of duct tape along the upper edge of the plastic greatly increased its longevity in the field and made take down easy since it allowed the entire 8 foot strip to be pulled from the 1 x 2 inch wooden lath in most cases. Putting duct tape on both sides of the plastic when it is installed would prevent the occasional tears that occurred when pulling a sheet off the lath to remove it.</p> <p>Cutting the plastic sheets into strips was more work and made them harder to handle during both</p>		

installation and removal and more difficult to store.  
Whether the vertical strips were any more effective than the sheets in deterring nesting is undetermined at this time and should be tested further.  
Photographs were taken of the culvert before the plastic was removed. We found only one 3 inch wide strip that had blown free during all the time that the plastic was in the field.  
The wooden lath used in this installation will remain in the CBC as agreed with Ron Jones, City of Broomfield

Deterrents were removed on September 23, 2010 by Jeff Peterson (Colorado Department of Transportation-CDOT) and D. Jean Tate. Of the observations made during removal of the deterrents, the following are most important:

- The deterrents all weathered quite well through two winters with the plastic strips and the corner slope plastic remaining flexible.
- The black plastic may have been slightly more flexible when it was removed indicating that it was slightly less affected by UV light.
- Use of GE Silicone II to mount the commercial Bird Slide product made them easy to remove, but also allowed them to blow down during the winter. It would best be used for single season applications.
- The corner slope constructed from plastic and metal grooves was the best corner slope solution for multiple seasons, but it should be installed on the lath with screws rather than nails. Also, an alternative to the metal grooves should be sought that is easier to install and handle.
- The plastic strips were the easiest deterrent to install and remove and appeared to be as effective as the corner slopes, but more testing of these deterrents is needed. Although no swallows nested in the CBCs so modified, this could have been for reasons other than presence of the plastic strips. Future testing should be done in a CBC containing an active colony with the plastic strips being placed intermittently down the length of the CBC in 8-foot long areas from which nests have been removed prior to the nesting season. This could allow testing of how close swallows will nest to the strips and any differences in effectiveness between plastic that is left in 8-foot long sheets and that cut into 3-inch vertical strips.

Ron Jones, City of Broomfield, was contacted on September 29, 2010, to let him know that all deterrents had been removed, except for the blue paint and the lath strips, which we had agreed could be left in the CBCs.

Photos taken on September 23, 2010, are provided in Figures 1 through 8. They show the condition of the deterrents prior to removal, the condition of the CBCs following removal, the nests present in the northernmost CBC, and the dead swallow and unhatched eggs observed during removal of the deterrents.



**Figure 1. Northernmost CBC with Corner Slope Deterrents.**



**Figure 2. One of Southern CBCs with Plastic Strip Deterrents.**



**Figure 3. Nests in Northernmost CBC where Corner Slopes Have Blown Down.**



**Figure 4. Whitewash Apparent Below Several Nests in Northernmost CBC.**



**Figure 5. Nests with Unhatched Eggs and Dried Grasses.**



**Figure 6. Adult Cliff Swallow Caught on Protruding Wire.**





**Figure 7. Jeff Peterson Removing Plastic Strips from Lath.**



**Figure 8. Lath Remaining After Removal of Plastic Strips; Blue Ceiling of Adjacent CBC Visible in Left of Photo.**

This has been a most interesting project. CDOT is to be commended for exploring ways to temporarily deter swallows from nesting in specific locations, while enabling them to nest in most CDOT structures, most of the time. This allows populations of Cliff Swallows to expand, reduces populations of flying insects via natural controls, and also diminishes the need for chemical control of flying insects.

Further research on the effectiveness of plastic strips as temporary deterrents would provide an effective finale to this project. It is hoped that CDOT will undertake such research in the next several years.

## APPENDIX B - INFORMATION SHEET TO GUIDE WORKERS IN CLEANING UP PIGEON DROPPINGS AND NEST DEBRIS

### Information Sheet to Guide Workers in Cleaning Up Pigeon Droppings and Nest Debris (see tabular summary for insertion into Job Safety Form 352)

<b>Activity Name: Bridge Structure Cleaning &amp; washing Decks</b>		<b>Activity Number: 352</b>	
<b>Activity Description &amp; Purpose: Sweeping, cleaning, or washing of bridge structures. Includes weep holes, deck, curbs and gutter, expansion devices. Also includes hand sweeping and shoveling of accumulated debris.</b>			
Typical Equipment		PPE Required	
Description	Class Code		
<ul style="list-style-type: none"> <li>• V M B</li> <li>• Loader Under 1 Yd</li> <li>• Sweeper Mechanical</li> <li>• Trailer - Under 10 ton</li> <li>• Sign Truck w/ arrow board</li> <li>• Attenuator Truckw/arrow board</li> <li>• 1/2 Ton Dump Truck w/mag tank</li> <li>• air compressor</li> <li>• one ton dump</li> </ul>	<ul style="list-style-type: none"> <li>• 903</li> <li>• 252</li> <li>• 528</li> <li>• 602</li> <li>• 635-902</li> <li>• 651-902</li> <li>• 658</li> <li>• 26</li> <li>• Backing truck or equipment into objects/ people or off the side of a trailer, Unsecured loads, Tripping, Falling, Pinching, Crushing, Moving Parts, Burns, Lifting, Bending, Pulling, Twisting, Traffic</li> </ul>	<ul style="list-style-type: none"> <li>• Hardtoe Boots</li> <li>• Hardhat</li> <li>• Reflectorized Vest</li> <li>• Safety Glasses</li> <li>• Hearing Protection</li> <li>• Appropriate Gloves (light colored with long cuffs),</li> <li>• Long-sleeved Shirt</li> <li>• Dust Mask or Air Purifying Respirator (e.g., high quality "3M" N-95 Hospital Grade Particulate Breathing Mask or similar that filters down to 3 microns) depending on quantity and dustiness of debris</li> <li>• Insect Repellent</li> </ul>	
Sequence of Job Tasks	Potential Hazards	Safe Job Procedures	Never
1. Make any prior	• Removal effort will be	• Pre-inspect the site to determine the extent of debris and the	• Cleanup a site with

arrangements needed for successful debris removal	compromised because needed equipment is not present or immediate disposal cannot be accomplished	<p>tools and PPE required</p> <ul style="list-style-type: none"> <li>• Assemble equipment such as plastic garbage bags or other containers, shovels, and any vacuums determined necessary</li> <li>• Check with local government agencies to determine whether disposal of the waste is permissible through standard trash pickup</li> <li>• If not, dispose in notified landfills (check to see if material contaminated with fungal spores is considered to be infectious waste...if so may need to be incinerated or disposed of in other than a landfill)</li> <li>• Treat any unprotected birds encountered humanely</li> <li>• Avoid sites occupied by protected bird (or bat) species</li> </ul>	<p>extensive debris without pre-planning and pre-inspection</p> <ul style="list-style-type: none"> <li>• Cleanup a site if it is occupied by a protected bird (or bat) species—pigeons are not protected</li> </ul>
2. Select crew	<ul style="list-style-type: none"> <li>• Selection of crew members predisposed to respiratory disease or allergic reactions</li> </ul>	<ul style="list-style-type: none"> <li>• Choose healthy individuals; avoid individuals with a history of extensive respiratory disease or allergies</li> <li>• Read (and have selected crew read) the information on Risks to Human Health and Safety that follows this table—these risks are real but unlikely to result in disease, especially if the protective measures discussed herein are followed</li> </ul>	<ul style="list-style-type: none"> <li>• Choose individuals with compromised immune systems</li> <li>• Require uninformed individuals to cleanup bird droppings and nest debris—their concerns are likely to exceed reality</li> </ul>
3. Assemble appropriate PPE	<ul style="list-style-type: none"> <li>• Arriving at location without appropriate PPE that fits crew members selected</li> </ul>	<ul style="list-style-type: none"> <li>• Have each crew member select their own PPE to be sure it fits them</li> </ul>	<ul style="list-style-type: none"> <li>• Select PPE in the field from a random selection of types and sizes available in a grab bag</li> </ul>
4. Prepare water to dampen debris	<ul style="list-style-type: none"> <li>• Splashing surfactant into eyes</li> </ul>	<ul style="list-style-type: none"> <li>• Add a surfactant (wetting agent) such as a detergent to the water to ensure that water adheres to the droppings and nest debris</li> </ul>	<ul style="list-style-type: none"> <li>• Dispose of surfactants anywhere except in a sewage system where they will be treated before entering the environment</li> </ul>
5. Don PPE	<ul style="list-style-type: none"> <li>• Wearing inappropriate, ill</li> </ul>	<ul style="list-style-type: none"> <li>• After inspecting site, supervisor should determine site-</li> </ul>	<ul style="list-style-type: none"> <li>• Wear inappropriate,</li> </ul>

	fitting, or damaged PPE. <ul style="list-style-type: none"> <li>Wearing PPE improperly</li> </ul>	specific PPE needs and instruct crew regarding what to wear and how to wear it	damaged, or ill fitting PPE <ul style="list-style-type: none"> <li>Wear PPE improperly</li> </ul>
6. Prepare site situation for cleanup	<ul style="list-style-type: none"> <li>Allowing droppings and nest debris to become airborne and more subject to being inhaled</li> </ul>	<ul style="list-style-type: none"> <li>Shut down or seal any heating and cooling air ducts that might cause currents that would blow the debris around</li> <li>Work from the upwind side of the site to be cleaned and avoid cleaning heavily contaminated sites on extremely windy days</li> </ul>	<ul style="list-style-type: none"> <li>Clean up extensive bird droppings or nest debris when high winds can cause the debris to become airborne</li> </ul>
7. Dampen droppings and nest debris.	<ul style="list-style-type: none"> <li>Inhaling small particles from droppings or nest debris that may contain bacteria, protozoa, or fungi if they become airborne</li> </ul>	<ul style="list-style-type: none"> <li>Lightly sprinkle or mist debris with prepared water before disturbing it.</li> </ul>	<ul style="list-style-type: none"> <li>Use so much water that it discharges beyond the cleanup site.</li> </ul>
8. Collect dampened droppings and nest debris	<ul style="list-style-type: none"> <li>Inhaling bacteria, protozoa, or fungi (especially spores)</li> <li>Becoming temporarily infested with ectoparasites that are living in the debris</li> <li>Being bitten by mosquitoes that contain viruses</li> </ul>	<ul style="list-style-type: none"> <li>Remain alert to the presence of "dust" in the air, ectoparasites crawling up gloves (before they reach the cuffs), and buzzing mosquitoes</li> <li>Keep hands away from mouth</li> <li>Shovel or scoop debris into containers that can be securely closed. The volume and weight of debris will determine whether plastic garbage bags or more sturdy containers are appropriate. If using plastic garbage bags check their weight frequently so they do not become so heavy that they will tear.</li> <li>Alternatively, use a hi-efficiency HEPA filter industrial vacuum cleaner (truck or trailer mounted); long, large diameter vacuum hoses keep workers away from source</li> <li>If actual scrubbing of the surface beneath the accumulated debris is required because of stringent site-specific cleanup requirements, consider use of a device similar to a carpet cleaner that uses hot water or steam that is simultaneously applied and vacuumed up.</li> </ul>	<ul style="list-style-type: none"> <li>Eat or smoke during cleanup operation</li> <li>Ignore extensive "dust" in the air, crawling ectoparasites, or buzzing mosquitoes</li> <li>Allow liquid from cleanup sites to enter the watershed</li> </ul>
9. Dispose of containers	<ul style="list-style-type: none"> <li>Leaving bird droppings or nest debris where it might be</li> </ul>	<ul style="list-style-type: none"> <li>Dispose of secured debris immediately</li> </ul>	<ul style="list-style-type: none"> <li>Improperly dispose of debris containers</li> </ul>

	encountered in high concentrations by children, the elderly, or those with compromised immune systems		<ul style="list-style-type: none"> <li>• Store debris because containers can break and/or ectoparasites can crawl out</li> </ul>
10. Clean up	<ul style="list-style-type: none"> <li>• Ingesting or inhaling bacteria, protozoans, or fungi remaining on clothing or hands</li> <li>• Dispersal of unnoticed ectoparasites on your person, which may temporarily cause discomfort</li> </ul>	<ul style="list-style-type: none"> <li>• When finished and while still wearing a respirator, remove protective clothing (gloves, hat, coveralls and boots) and place it in a plastic bag; wash or dispose of it as appropriate</li> <li>• Wash or shower at the work site after clean-up</li> </ul>	<ul style="list-style-type: none"> <li>• Eat or smoke prior to cleaning up</li> <li>• Continue with other activities without cleaning up</li> </ul>
11. Determine if site modification is appropriate	<ul style="list-style-type: none"> <li>• Reaccumulation of debris in sites that are heavily used, which is undesirable if these sites are immediately adjacent to extensive pedestrian use or long-term storage of vehicles or equipment</li> </ul>	<ul style="list-style-type: none"> <li>• Modify the structure to prevent birds or bats from reestablishing the roost if necessary</li> <li>• For information on deterrents, read the Final Report: Research Study Progress Report: Bird Nesting and Droppings Control on Highway Structures, Study No: 41.76</li> <li>• Because modification of existing structures is expensive, be selective in recommending sites for modification; consider the need for ongoing maintenance of retrofitted deterrents and carry through on this maintenance.</li> <li>• Be alert to locations where new or replacement of structures can more cost effectively incorporate deterrents during initial construction</li> </ul>	<ul style="list-style-type: none"> <li>• Modify sites that are being actively used by protected bird (or bat) species</li> </ul>

## **Risks to Human Health and Safety**

Birds, including pigeons and swallows, have diseases, internal parasites, and ectoparasites. Some of these diseases and parasites can infect humans, but most are unlikely to do so. Further, if humans are infected, it is likely to be only temporarily. This is because most diseases and parasites have adapted to their normal host's physiology. Birds have a higher body temperature (103-108°F) than humans (98.6°F). This is significant in physiological terms and makes humans an unlikely long term host for avian parasites.

Long lists of diseases associated with birds tend to be provided on web sites that also sell products to deter birds from roosting or nesting. However, based on an article on avian diseases transmissible to humans prepared by the University of Florida for bird keepers<sup>8</sup>, the most likely diseases that can be contracted by humans from birds are the following:

- ornithosis—caused by a bacteria-like organism that may be inhaled with fecal dust or ingested with feces or saliva from birds or humans, causing a feverish respiratory disease that can be serious in humans if complications in the spleen or heart occur;
- salmonellosis—caused by numerous species of Salmonella bacteria that can cause infections when feces are ingested by most animals, including humans who may have diarrhea, vomiting and low grade fever or more progressive symptoms leading to serious illness, especially if they are very young or old;
- colibacillosis—caused by bacteria that inhabit the intestinal tract of all animals, including humans but which may cause diarrhea and potentially other complications when ingested;
- avian tuberculosis—caused by bacteria that in humans can cause local wound infections;
- cryptosporidiosis—caused by protozoa and potentially causing abdominal pain, nausea, and watery diarrhea, with more severe symptoms occurring in immunocompromised people;
- allergic alveolitis—caused by acute or chronic exposure and a hypersensitive reaction to excessive quantities of avian dander, feces, or feathers that result in inflammation of the pulmonary alveoli, reduced lung capacity, and other pulmonary symptoms; and the fungal and viral diseases discussed below.

Histoplasmosis and cryptococcosis are naturally occurring fungi that proliferate when the soil where they occur is augmented with bird droppings. These fungi can cause pulmonary diseases in humans, particularly if their immune systems have been compromised.

Some diseases of particular concern to humans such as bird flu and west Nile virus can be contracted by both birds and humans. The bird flu virus must mutate before it can be contracted by humans. There is evidence that this has happened in some parts of the world, but the virus has not yet been found in birds in North America. Further, no human

---

<sup>8</sup> Jacob, J.P., J.M. Gaskin, H.R. Wilson, and F.B. Mather. 1997. Document PS23, Animal Science Department, Florida Cooperative Extension Service, Institute of Food and Agricultural Sciences, University of Florida.. (<http://edis.ifas.ufl.edu/pdf/files/PS/PS01900.pdf>)

cases have yet been linked to exposure to wild birds. Close contact with infected poultry and other domestic birds remains the most important source of human infections.

Humans contract west Nile virus (and western equine encephalitis) after being bitten by a mosquito carrying the virus. The virus is carried by animals such as birds, dogs, cats, and horses. Because west Nile virus results in very high and rapid mortality in birds, they are not as likely as the other virus carriers to be bitten by a mosquito that ingests the virus and then bites a human.

The ectoparasites carried by birds (bugs, fleas, lice, mites, ticks, and other biting insects) prefer to remain on their avian hosts. However, large populations of ectoparasites may remain in nests after the young have fledged, or in roosting site debris if the birds formerly present have been removed. These ectoparasites may crawl onto nearby humans, who might be bitten by them. Other than causing short term irritation, avian parasites are unlikely to damage temporary human hosts, although unusual cases of hypersensitivity and hyper-reactivity in humans have been reported.

At the end of the discussion by the University of Florida Extension Service, are the following statements:

"Bird-keepers should be aware that they can contract certain illnesses from their birds. The frequency of disease transmission from birds to humans is low, but the very young, the elderly, and those with compromised immune systems should be cautious.

Many of these diseases are transmitted by ingestion of food contaminated by fecal matter. Prevention of most of these diseases, therefore, simply involves proper hygiene and sanitation. Wearing a face mask to avoid inhaling bird dust is also recommended.

If you have persistent flu-like symptoms when no one else you know is affected, see a doctor and mention that you raise birds. Such symptoms may be indicative of a disease spread from birds to humans. "

Keep in mind that this rather mild warning is geared toward bird keepers who frequently contact birds that are kept in confined conditions. Some of the diseases discussed above are also most likely contracted by those who work in the poultry industry or avian diagnostic laboratories where exposure is more likely. Occasional contact with birds and their droppings or nest materials such as experienced by CDOT personnel is unlikely to result in disease, especially if the protective measures discussed below are followed.

## **APPENDIX C - SAFE OPERATING GUIDE**

### **SAFE OPERATING GUIDE**

Revised: 2/16/99

Additional revisions for bird droppings/nesting material suggested: 12/31/09

#### **0100.00 PERSONAL PROTECTIVE EQUIPMENT**

Personal protective equipment provides the employee the first line of defense against injury.

Wearing personal protective equipment is an added safety feature, not a substitute for necessary safety procedures. Personal protective equipment should not give an employee a false sense of security.

#### **ALWAYS**

- Use proper personal protective equipment
- Be familiar with the limitation of personal protective equipment and do not exceed the levels of protection it provides.
- Select one item of personal protective equipment that will be compatible with another and that will not interfere with the intended use of other personal protective equipment items.
- Inspect, clean and maintain personal protective equipment for maximum protective capability.
- Replace defective or damaged personal protective equipment.

#### **Head Protection**

- Wear a CDOT-issued orange hard hat when there is a risk of head injuries from falling objects, flying materials or if exposed to electrical conductors.
- Wear a CDOT-issued orange hard hat at the direction of the supervisor.
- Wear a CDOT-issued orange soft cap for visibility and identification where the hard hat is not required.
- Wearing a wider brimmed hard hat or soft cap may reduce excessive sun exposure. The
- wider brimmed head protection must be orange for visibility, identification and must meet
- CDOT requirements.
- Check the hard hat for cracks, dents, discoloration, brittleness and frayed or torn suspension.
- Replace damaged parts or replace the hard hat as necessary.

#### **Hearing Protection**

- The goal of hearing protection is to reduce the exposure to harmful noise but allow machine
- warnings and conversation to be heard.



- Wear hearing protection when noise levels in the work environment exceed 80dba. Noise level examples are soft music (30 dba), normal speech (60 dba), shop tools (80 dba), sandblasting (115 dba), and explosive blast at peak (140 dba).
- Wear hearing protection to meet or exceed the OSHA attenuation criteria by utilizing CDOT-issued earplugs and/or earmuffs.
- Earmuffs are made specifically for certain noise levels and work environments. A perfect seal between the muff and the skin around the ear is required, otherwise, earmuffs will provide a minimum level of protection; ensure that hair, jewelry and glasses do not interfere with the seal.
- Wear multiple hearing protection when necessary to reduce sound and when extended time is required to complete an activity.
- Hearing protection attenuation resulting in dba above 90 is subject to OSHA time restrictions.

### **Eye & Face Protection**

- Wear safety glasses when there is a risk of injury to the eye. At any time there is a danger of injury by flying objects, you must fit safety glasses with side shields or wear safety goggles.
- Wear safety glasses when operating various power tools or machines, which may throw particles.
- Wear safety glasses when working with a battery.
- Wear safety goggles when needed to protect the eyes from dust and mist.
- Wear safety goggles when there is a danger of foreign objects entering the eye from the side.
- Wear face shields when there is a splash danger from chemicals or other substances that may cause injury to the face or neck.
- Wear safety eyewear, equipped with special filters, when exposure to injurious light rays or other radiant energy is apparent.
- Prescription glasses and contact lenses will not protect the eyes. Contact lenses alone can be more hazardous and cause eye injury if dust or materials are lodged under the lenses.
- Wear safety glasses, goggles or face shields at the direction of the supervisor.

### **Respiratory Protection**

- Employees must receive training and re-training as necessary prior to being required to utilize respiratory protection in a work activity.
- Respiratory protection is required for two basic hazardous environments and/or atmospheres, oxygen-deficient and contaminated. If an environment or atmosphere contains less than 19.5% of oxygen by volume, it is considered oxygen-deficient. Confined spaces are potentially oxygen-deficient environments. Inhalation is the quickest way for contaminants to enter the bloodstream. The respiratory system must be protected from a contaminated atmosphere that has dust, spray, fume, vapor, smoke, biohazards, or harmful gas exposure.
- Base selection of respiratory protection on results of workplace atmospheric sampling, if necessary, the nature of the work activity, the amount of time spent on a

specific work task and the activities expected to be performed while wearing a respirator. There are two (2) basic types of respirators, air purifying and supplied-air.

- Be medically certified to wear a respirator.
  1. Air-purifying respirators are available in three (3) basic types, particulate removing, vapor and gas removing and a combination of the two. Air-purifying respirators are approved for use only when the atmosphere contains sufficient oxygen to sustain life, contaminant concentration is known and/or contaminant levels or particle sizes do not exceed the limitation of the facepiece or cartridge.
  2. Supplied-air respirators are available in two (2) common types, self-contained breathing apparatus (SCBA) and airline respirator. Both types provide breathing air from an outside source of air to a mask or hood. The SCBA supplies air from tanks and provides the highest level of respirator protection and positive pressure. SCBA is more commonly used in rescue or emergency situations. The SCBA provides protection for both oxygen deficiency and contaminants that are immediately dangerous to life or health.
- Employees that will have extensive use of respiratory protection will be trained, medically evaluated and fit-tested.
- Wear respiratory protection when required by a product or Material Safety Data Sheet when performing such work activities as mixing and applying specific herbicides; spraying chemicals, including paints; and welding or cutting galvanized metals.
- Wear respiratory protection at the direction of the supervisor.
- When removing high concentrations of bird droppings or nest debris, wet them down (avoiding discharge) to minimize the extent to which they become airborne and respirable.
- Wear an air purifying respirator (e.g., high quality "3M" N-95 Hospital Grade Particulate Breathing Mask) when working with bird droppings or nesting material as an added precaution against inhaling bacteria, fungus, or virus particles that may be present.
- Proper respirator maintenance is required to ensure maximum capability and will include inspection, decontamination and storage.

### **Hand and Arm Protection**

- Wear work gloves during any operation when there is a risk of abrasion, laceration, burns, blisters or punctures to the hands and when ectoparasites may be present.
- No single glove type will protect against all potential hand hazards. There are four general glove classifications:
  1. General purpose: made of either leather or cotton, the gloves offer minor protection from abrasions, cuts, punctures, snags and minor temperature variations. Leather gives an overall better protection.
  2. Cut-resistant: made of wire or metal mesh to provide reinforcement against a cutting potential
  3. Special purpose: manufactured according to the work activity exposure. As an example welding and firefighting use specially insulated gloves designed for use in extreme heat.
  4. Chemical-resistant: made of several different types of materials for resistance to specific chemicals and prevents contact with or absorption of hazardous chemicals into the body. The gloves must be non-porous.

- Inspect the gloves for rips, holes or anything that may weaken the effectiveness. Either repair or replace damaged gloves prior to a potential exposure.
- Ensure that the gloves fit properly, a glove too big or small will not provide adequate protection.
- Wear light colored general purpose gloves with long cuffs when removing bird droppings or nesting material so any ectoparasites that move from these materials to your hands can be more readily seen.
- Wash hands thoroughly and wash or discard gloves after handling bird droppings or nesting material.

### **Body and Leg Protection**

- Wear a CDOT-issued safety vest with reflectorized or high visibility material when performing duties on the roadway.
- Wear coveralls and/or long sleeved shirts when welding, cutting or exposed to poisonous plants or hot materials.
- Wear clothing that is fire and/or heat resistant when work activity has high-voltage, heat or fire exposure.
- Wear specific chemical resistant clothing if the work activity has a chemical exposure.
- Wear long sleeves with cuffs tucked inside long work glove cuffs when removing bird droppings or nesting material to reduce the likelihood that ectoparasites that may be present will temporarily use you as their host.
- Wash clothing thoroughly after handling bird droppings or nesting material.

### **Foot Protection**

- All employees except those who do not have regular exposure to hazardous conditions or who have obtained a doctor's certificate shall wear safety footwear.
- Safety footwear is the responsibility of the employee and shall not be provided by CDOT except for metatarsal (foot) guards for specific work activities.
- Safety footwear is designed to guard against impact or compression and should be appropriate for the work activity and exposure.
- Wear safety footwear with a sturdy reinforced toe area if the work activity requires handling heavy objects, parts or tools.
- Wear safety footwear with puncture-resistant soles if the work activity has a potential for sharp objects to penetrate the feet.
- Wear safety footwear that is non-conductive if the work activity has an electrical exposure.
- Wear safety footwear with conductive properties to transfer static charge into the ground, if the work activity requires a static charge free environment.
- Wear non-sparking safety footwear if the work activity has an explosive mixture hazard.
- Wear safety footwear that is specially coated to resist chemicals if the work activity has a chemical exposure.

## ***Special Considerations***

### **Avalanche Operations**

- Utilize the additional personal protective equipment, rescue transceiver/beacon, rescue probe pole, rescue snow shovel, high quality flashlight and fifty (50') feet of climbing rope provided to you.
- Prepare for extreme weather and temperature conditions by wearing warm garments in multiple layers, including insulated coveralls.
- Use multiple hearing protection, both earplugs and earmuffs, when firing artillery during avalanche control and training functions. Wear a flight helmet when operating in a helicopter.
- Wear a full body harness, connected to a hard point of the helicopter frame when working with the helicopter door open.

### **Bird Droppings and Nesting Materials (Removal)**

See Safe Operating Guide and Information Sheet to Guide Workers in Cleaning Up Pigeon Droppings and Nest Debris (tabular summary for insertion into Job Safety Form 352) for specific risks and precautions associated with removal of bird droppings and nesting materials.

### **Bloodborne Pathogens**

- Use preventive housekeeping around surfaces soiled with blood and body fluids with appropriate disinfectant.
- Utilize personal protective equipment, when the potential of encountering infectious substances, by wearing gloves and body protection, such as a protective smock or apron, eye protection and respirator protection.
- Remember to protect yourself when CPR is needed. Unprotected mouth-to-mouth resuscitation can be hazardous to you because the victim may have blood or bloody vomit in the mouth. Give CPR only if you are trained to do so. Be prepared by keeping a pocket mask available to protect you from the victim's saliva and body fluids.
- Be on alert for sharp objects such as broken glassware or used syringes. Always use a brush and dustpan, tongs or forceps to pickup potential hazards. Place contaminated sharp objects and other contaminated wastes or cleaning materials in sturdy, leak-proof containers and dispose of according to proper procedures.
- Cover spills with absorbent sweep material to prevent fluid from spreading. Spills should be cleaned up with a germicidal cleaning agent or fresh solution of one part bleach diluted with 100 parts of water (or ¼ cup bleach to 1 gallon of water)
- Keep your hands away from your face especially your nose, mouth and eyes when working around areas that might be contaminated. Be sure to wash your hands and remove any protective clothing before eating, drinking, smoking, applying cosmetics or lip balms or handling contact lenses.
- If an exposure occurs, don't panic. If you get blood or body fluids on your gloves, clothes or shoes, remove them as soon as possible and place in a sealed plastic bag. Next wash your skin with non-abrasive soap and water. If you do get blood or body fluids on your skin, wash it off immediately with non-abrasive soap and water. Flush

exposed mucous membranes with water. If a substance gets into your eyes, immediately flush your eyes with running water at a sink or eyewash.

- Wash your hands thoroughly and promptly after contact with blood or body fluids, even if gloves or other barriers were used. Wash hands with soap and running water for at least 15 seconds and dry with disposable towels.
- Report an incident immediately to your supervisor. If you are exposed to a potentially infectious substance, CDOT can advise you about testing, counseling and any other steps to be taken.
- Be properly trained and authorized to clean spills of blood, or other body fluids visibly contaminated with blood.

### **Confined Space**

- Reference and review the CDOT Confined Space Entry Program when engaging in a confined space work activity.
- Wear appropriate and prescribed personal protective and respiratory equipment for the specific work activity and environment. Safety harnesses and lifelines must be attached to prevent snagging in the event of an emergency.
- Test the air inside the confined space for flammable, explosive and toxic vapors and gases before entry. If necessary, test again while work is in progress to ensure continued safety.
- Use spark-proof tools and explosion-proof fans, lights or air movers if environment has an explosive potential.
- Have trained and equipped workers involved in the work activities. Good communication is essential.

### **Electrical**

- Hard hat
- Voltage gloves

### **Emergency Response and Firefighting**

- Bunker equipment (helmet, coat, pants, gloves, boots, etc.)
- SCBA

### **Explosives**

- Multiple hearing protection
- Safety glasses

### **Fall Protection**

- Utilize fall protection (body harness w/ lanyard, safety rail or net) when in the bucket of a traffic truck.
- Utilize fall protection (body harness w/ lanyard, safety rail or net) when working on unguarded work platforms where the fall would be more than ten (6) feet.

### **Hazardous Materials**

- Utilize special impermeable gloves when working with hazardous chemicals or as directed by the Material Safety Data Sheets.
- Utilize rubber boots when required by the Material Safety Data Sheet.
- Utilize rubber boots when mixing and applying specific pesticides.

### **High Scaling**

- Head protection including chinstraps
- Hand protection
- Fall protection

### **Water Hazards**

- Utilize flotation vests or life jackets when working over or near water where a drowning danger exist.
- Inspect flotation vests or life jackets for defects that could alter buoyancy.
- Utilize flotation vests or life jackets that are U. S. Coast Guard approved.

### **Welding**

- Head protection
- Hand protection
- Eye and face protection
- Respiratory protection

### **NEVER**

- Use personal protective equipment without the proper training.
- Use personal protective equipment except for its intended purpose.
- Use personal protective equipment that is damaged or defective
- Sustain high exposure to biohazards—which may be associated with bird droppings, bird nesting material, mosquito bites, and highly organic soils—if you have a compromised immune system

### **PERSONAL PROTECTIVE EQUIPMENT**

All

### **POTENTIAL HAZARDS**

All

### **RELATED SAFE OPERATING GUIDES**

All